

SECTION 9: PARTS

Main

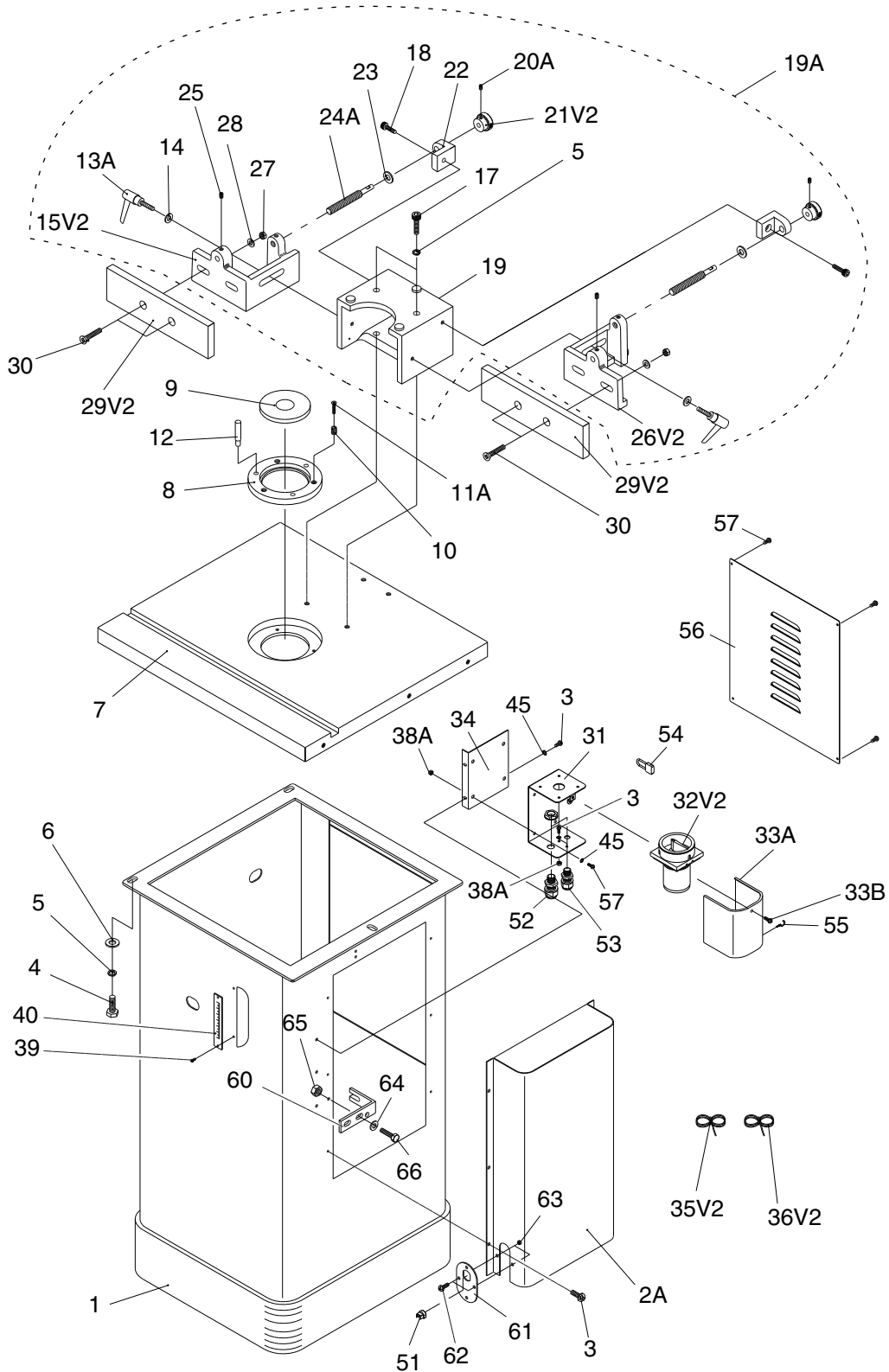

Main Parts List

REF	PART #	DESCRIPTION
1	P1035001	STAND (G1035)
1	P1035P001	STAND (G1035P)
2A	P1035002A	MOTOR COVER V2.01.06 (G1035)
2A	P1035P002A	MOTOR COVER V2.01.06 (G1035P)
3	PS06	PHLP HD SCR 10-24 X 3/8
4	PB21	HEX BOLT 3/8- 16 X 3/4
5	PLW04	LOCK WASHER 3/8
6	PW02	FLAT WASHER 3/8
7	P1035007	TABLE
8	P1035008	OUTER TABLE INSERT
9	P1035009	INNER TABLE INSERT
10	P1035010	BARREL SCREW 7/16-14 X 1/2
11A	PFH21	FLAT HD SCRW 10-24 X 3/4
12	P1035012	STARTING PIN
13A	P1026046	LOCK HANDLE 5/16"-18 X 1"
14	PW07	FLAT WASHER 5/16
15V2	P1035015V2	FENCE MOUNT LH 3/8 V2.01.09 (G1035)
15V2	P1035P015V2	FENCE MOUNT LH 3/8 V2.01.09 (G1035P)
17	PCAP14	CAP SCREW 3/8-16 X 1
18	PCAP07	CAP SCREW 5/16-18 X 3/4
19	P1035019	MAIN FENCE HOUSING (G1035)
19	P1035P019	MAIN FENCE HOUSING (G1035P)
19A	P1035019A	COMPLETE FENCE ASSEMBLY (G1035)
19A	P1035P019A	COMPLETE FENCE ASSEMBLY (G1035P)
20A	PSS05	SET SCREW 5/16-18 X 1/4
21V2	P1035021V2	KNURLED KNOB 8MM D32
22	P1035022	ADJ. SCREW BRACKET (G1035)
22	P1035P022	ADJ. SCREW BRACKET (G1035P)
23	PW07	FLAT WASHER 5/16
24A	P1035024A	FENCE ADJ SCREW 1/2-13 X 4-1/4 V2.10.00
25	PSS03	SET SCREW 1/4- 20 X 3/8
26V2	P1035026V2	FENCE MOUNT RH 3/8 V2.01.09 (G1035)
26V2	P1035P026V2	FENCE MOUNT RH 3/8 V2.01.09 (G1035P)

REF	PART #	DESCRIPTION
27	PN02	HEX NUT 5/16-18
28	PW07	FLAT WASHER 5/16
29V2	P1035029V2	WOOD FENCE FACE 2-3/4 V2.01.09
30	PFH23	FLT HD SCRW 5/16-18 X 1-1/2
31	P1035031	SWITCH BOX (G1035)
31	P1035P031	SWITCH BOX (G1035P)
32V2	P1035032V2	FWD/REV ROTARY SWITCH V2.04.10
33A	P1035033A	U-SWITCH COVER 4-7/8"T V2.10.02 (G1035)
33A	P1035P033A	U-SWITCH COVER 4-7/8"T (G1035P)
33B	PFS04M	FLANGE SCREW M4-.7 X 6
34	P1035034	SWITCH MOUNT BRACKET (G1035)
34	P1035P034	SWITCH MOUNT BRACKET (G1035P)
35V2	P1035035V2	MOTOR CORD 14G 5W 30" V2.04.10
36V2	P1035036V2	POWER CORD 14G 3W 56" 5-15 V2.04.10
38A	PN07	HEX NUT 10-24
39	PHTEK1	TAP SCREW #6 x 1/2"
40	P1026041	SCALE
45	PTLW01	EXT TOOTH WASHER #10
51	P1035051	STRAIN RELIEF SB8R-1
52	P1035052	STRAIN RELIEF MGB20-10B
53	P1035053	STRAIN RELIEF MGB16-10B
54	P1035054	SWITCH PADLOCK
55	P1035055	PADLOCK STORAGE HOOK
56	P1035056	REAR STAND PANEL
57	PFS03	FLANGE SCREW 10-24 X 3/8
60	P1035060	BOTTOM MOTOR BRACE
61	P1035061	CORD CLAMP PLATE
62	PS01	PHLP HD SCR 10-24 X 1/2
63	PN07	HEX NUT 10-24
64	PW07	FLAT WASHER 5/16
65	PN02	HEX NUT 5/16-18
66	PB07	HEX BOLT 5/16-18 X 3/4



Motor

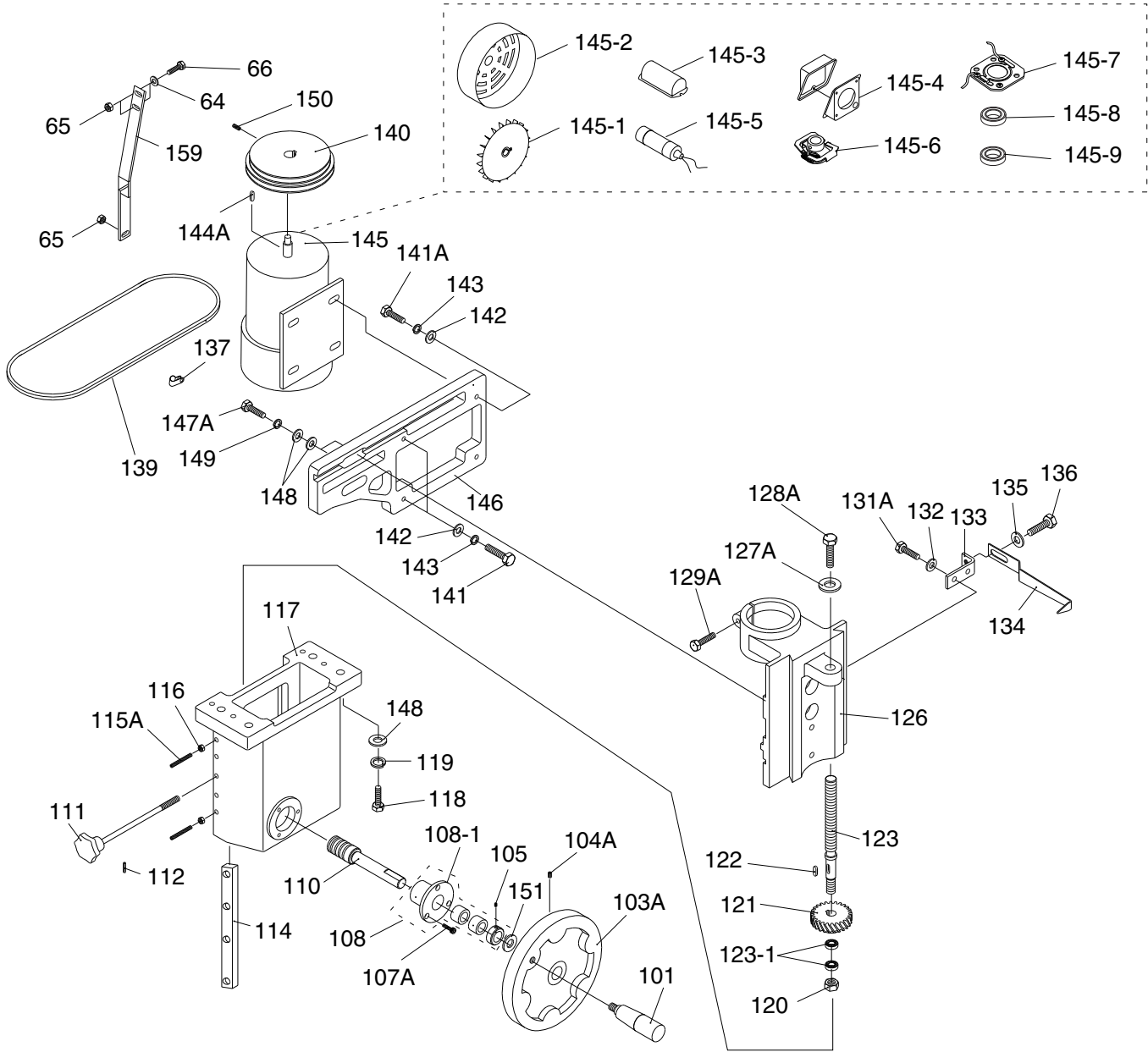

Motor Parts List

REF	PART #	DESCRIPTION
64	PW07	FLAT WASHER 5/16
65	PN02	HEX NUT 5/16-18
66	PB07	HEX BOLT 5/16-18 X 3/4
101	P1035101	HANDLE W/SCREW
103A	P1035103A	CAST IRON HANDWHEEL V2.07.06
104A	PSS15	SET SCREW 3/8-16 X 3/8
105	PSS11	SET SCREW 1/4- 20 X 1/4
107A	PCAP17	CAP SCREW 1/4-20 X 3/8
108	P1035108	SHAFT MOUNT ASSEMBLY
108-1	P1035108-1	SHAFT MOUNT
110	P1035110	WORM SHAFT
111	P1035111	HAND KNOB ASSEMBLY
112	PRP99M	ROLL PIN 2 X 12
114	P1035114	GIB
115A	PSS20	SET SCREW 5/16-18 X 1-1/2
116	PN02	HEX NUT 5/16-18
117	P1035117	ELEVATION HOUSING
118	PB16	HEX BOLT 3/8-16 X 1-1/2
119	PLW04	LOCK WASHER 3/8
120	PLN06	LOCK NUT 1/2-13
121	P1035121	GEAR 25T
122	PK20M	KEY 5 X 5 X 15MM
123	P1035123	ELEVATION LEADSCREW 5/8 X 10 V2.07.98
123-1	P51102	THRUST BEARING 51102
126	P1035126	SPINDLE SLIDE
127A	PW07	FLAT WASHER 5/16
128A	PB15	HEX BOLT 5/16-18 X 3/8
129A	PB12	HEX BOLT 5/16-18 X 1-1/4
131A	PB19	HEX BOLT 1/4-20 X 1/2
132	PW06	FLAT WASHER 1/4

REF	PART #	DESCRIPTION
133	P1035133	L-BRACKET
134	P1035134	POINTER
135	PW07	FLAT WASHER 5/16
136	PB15	HEX BOLT 5/16-18 X 3/8
137	P1035137	CABLE CLAMP
139	P1035139	V-BELT 7 X 600L
140	P1035140	MOTOR STEP PULLEY
141	PB03	HEX BOLT 5/16-18 X 1
141A	PB12	HEX BOLT 5/16-18 X 1-1/4
142	PW07	FLAT WASHER 5/16
143	PLW01	LOCK WASHER 5/16
144A	PK12M	KEY 5 X 5 X 30MM
145	P1035145	MOTOR 1-1/2 HP 110V/220V 1-PH
145-1	P1035145-1	MOTOR FAN
145-2	P1035145-2	MOTOR FAN COVER
145-3	P1035145-3	CAPACITOR COVER
145-4	P1035145-4	MOTOR JUNCTION BOX
145-5	PC300B	S CAPACITOR 300M 125V 1-3/4 X 3-3/8
145-6	PCS003	CENTRIFUGAL SWITCH 5/8-3450
145-7	PCP001	CONTACT PLATE
145-8	P6203ZZ	BALL BEARING 6203ZZ
145-9	P6204ZZ	BALL BEARING 6204ZZ
146	P1035146	MOTOR MOUNT PLATE (G1035)
146	P1035P146	MOTOR MOUNT PLATE (G1035P)
147A	PB16	HEX BOLT 3/8-16 X 1-1/2
148	PW02	FLAT WASHER 3/8
149	PLW04	LOCK WASHER 3/8
150	PSS02	SET SCREW 5/16-18 X 3/8
151	P1035151	HANDWHEEL LOAD WASHER
159	P1035159	TOP MOTOR BRACE



Spindle

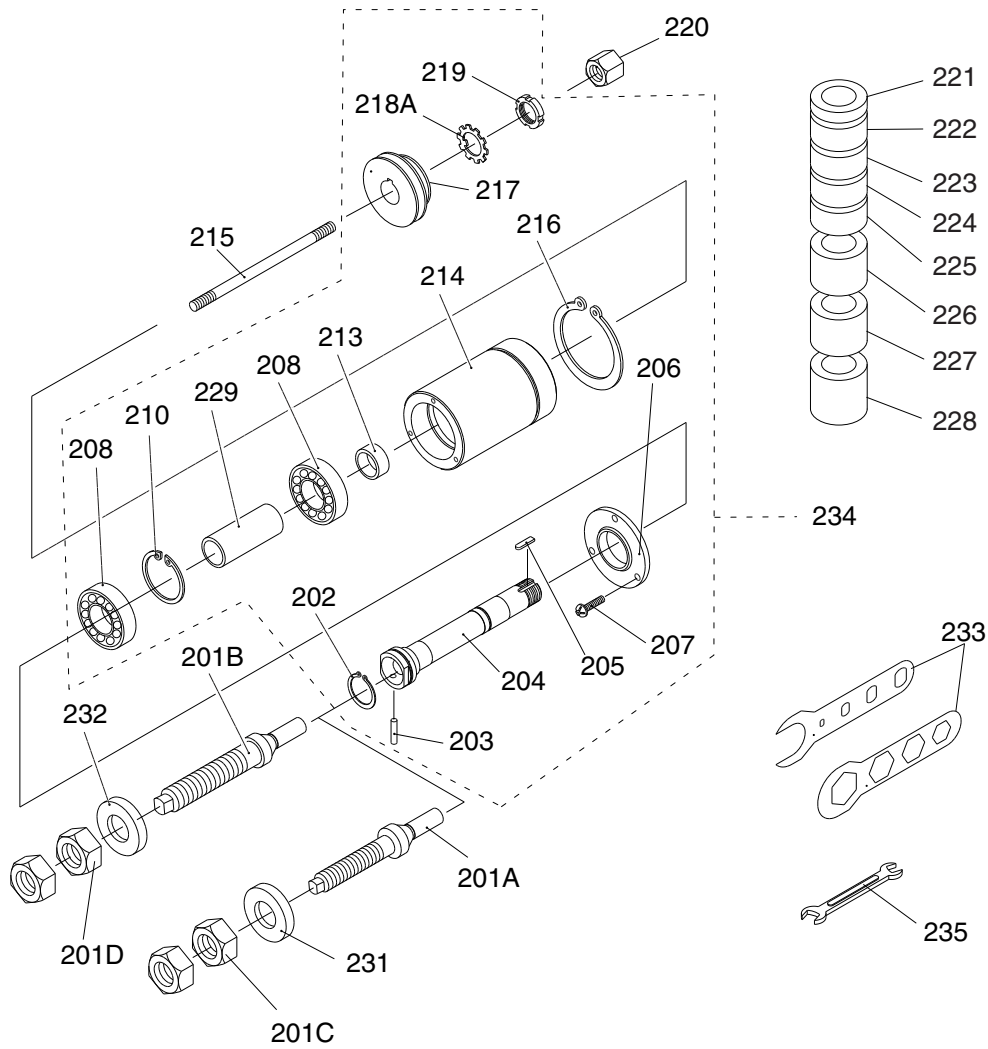

REF	PART #	DESCRIPTION
201A	P1035201A	SPINDLE 1/2"
201B	P1035201B	SPINDLE 3/4"
201C	P1035201C	SPINDLE NUT 1/2" 2PC SET
201D	P1035201D	SPINDLE NUT 3/4" 2PC SET
202	PR15M	EXT RETAINING RING 30MM
203	P1035203	PIN
204	P1035204	SPINDLE CARTRIDGE
205	PK20M	KEY 5 X 5 X 15
206	P1035206	HOUSING CAP
207	PS01	PHLP HD SCR 10-24 X 1/2
208	P6204ZZ	BALL BEARING 6204ZZ
210	PR25M	INT RETAINING RING 47MM
213	P1035213	SLEEVE
214	P1035214	BEARING HOUSING
215	P1035215	DRAWBAR
216	PR13M	EXT RETAINING RING 65MM
217	P1035217	STEP PULLEY

REF	PART #	DESCRIPTION
218A	P1035218A	SMALL TOOTHED WASHER 3/4"
219	P1035219	SPANNER NUT 3/4-10
220	P1035220	DRAWBAR NUT 5/16-24
221	G2454	SPACER 1/2" X 1" X 1/4"
222	G2455	SPACER 1/2" X 1" X 3/8"
223	G2456	SPACER 1/2" X 1" X 1/2"
224	G2457	SPACER 1/2" X 1" X 3/4"
225	G2460	SPACER 3/4" X 1-1/4" X 1/4"
226	G2461	SPACER 3/4" X 1-1/4" X 3/8"
227	G2462	SPACER 3/4" X 1-1/4" X 1/2"
228	G2463	SPACER 3/4" X 1-1/4" X 3/4"
229	P1035229	LONG SPACER
231	P1026223	SPINDLE WASHER 1/2 X 26 X 3
232	P1026224	SPINDLE WASHER 3/4 X 32 X 3
233	P1026226	SPINDLE WRENCH SET
234	P1035234	SPINDLE ASSEMBLY
235	PWR1214	WRENCH 12 X 14



Safety Guard

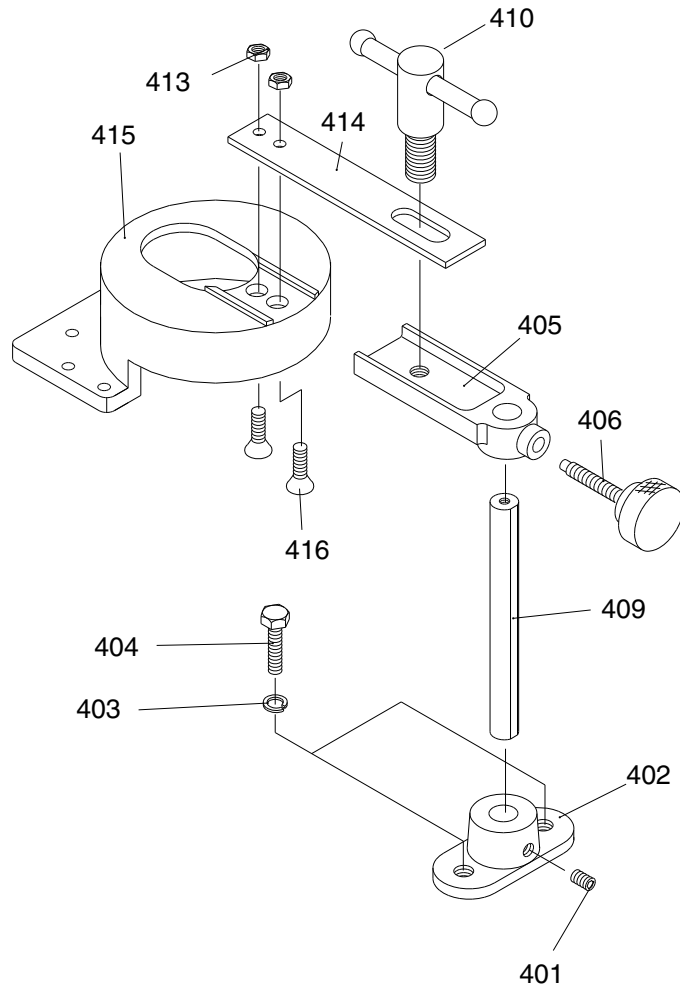

REF	PART #	DESCRIPTION
401	PSS02	SET SCREW 5/16-18 X 3/8
402	P1035402	SHAFT MOUNTING BRACKET (G1035)
402	P1035P402	SHAFT MOUNTING BRACKET (G1035P)
403	PLW04	LOCK WASHER 3/8
404	PB21	HEX BOLT 3/8-16 X 3/4
405	P1035405	EXTENSION BRACKET (G1035)
405	P1035P405	EXTENSION BRACKET (G1035P)
406	P1026306	LOCK KNOB ASSEMBLY

REF	PART #	DESCRIPTION
409	P1026309	SHAFT
410	P1026310	LOCK HANDLE ASSEMBLY
413	PN05	HEX NUT 1/4- 20
414	P1035414	EXTENSION BAR
415	P1035415	GUARD (G1035)
415	P1035P415	GUARD (G1035P)
416	PFH04	FLT HD SCR 1/4- 20 X 5/8



Hold-Downs

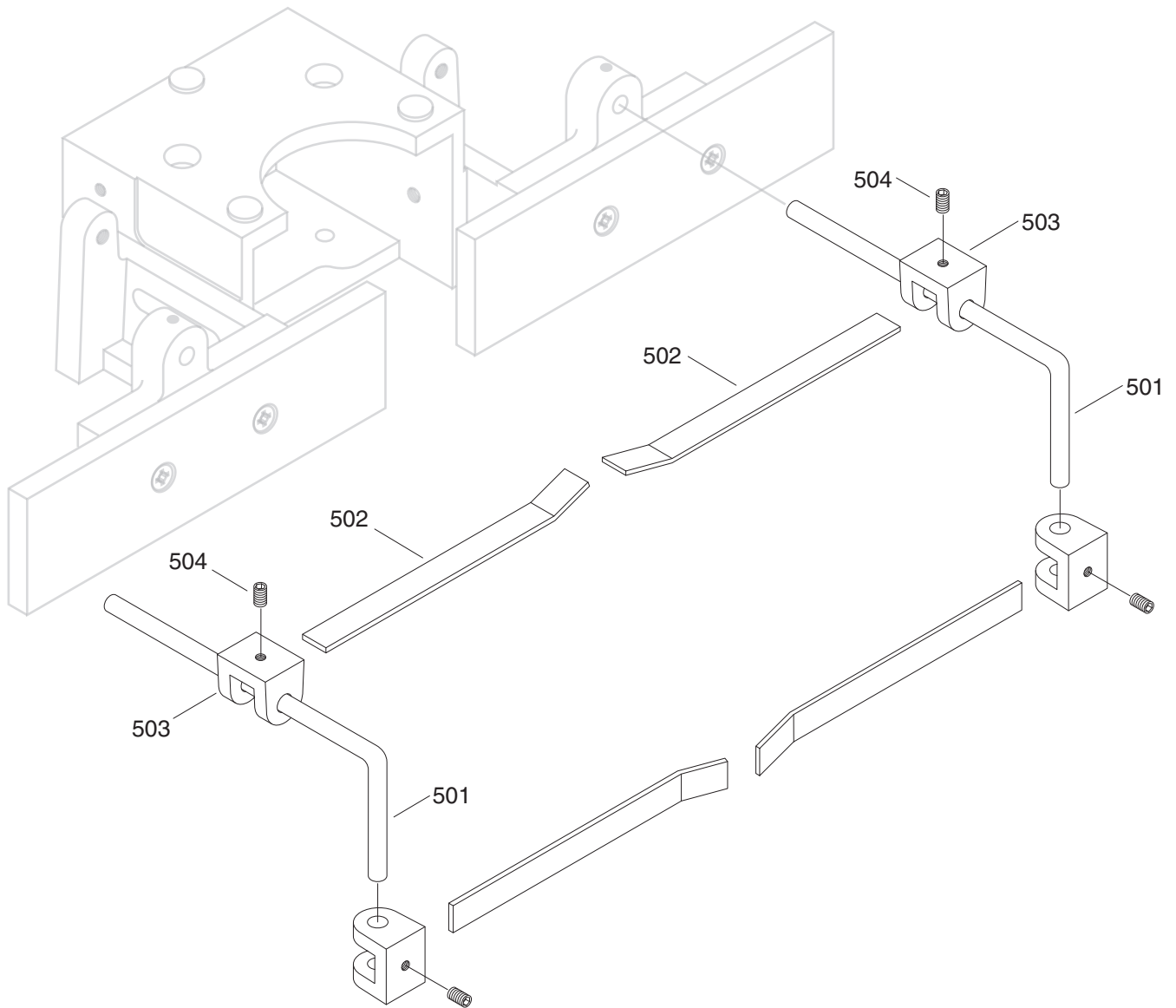

REF	PART #	DESCRIPTION
501	P1035501	HOLD DOWN BAR
502	P1035502	HOLD DOWN

REF	PART #	DESCRIPTION
503	P1035503	HOLD DOWN BRACKET
504	PSS03	SET SCREW 1/4-20 X 3/8



Miter Gauge

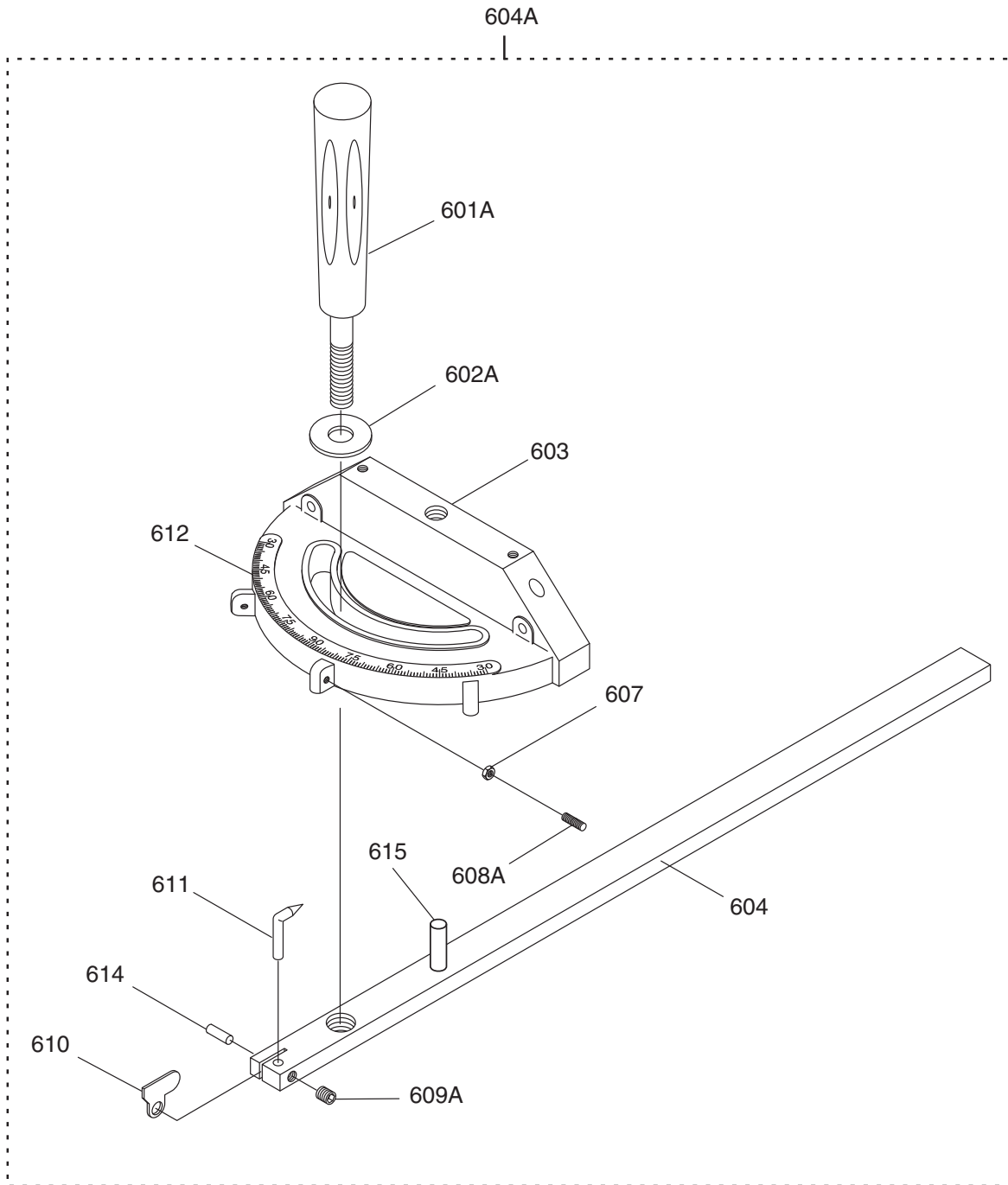

REF	PART #	DESCRIPTION
601A	P1023401A	MITER GAUGE HANDLE V2.10.01
602A	PW07	FLAT WASHER 5/16
603	P1026603	MITER GAUGE BODY V2.05.07
604	P1035604	MITER BAR
604A	P1035604A	MITER GAUGE ASSY V1.10.02
607	PN07	HEX NUT 10-24
608A	PSS32	SET SCREW 10-24 X 3/4

REF	PART #	DESCRIPTION
609A	PSS29	SET SCREW 10-24 X 1/4
610	P1026610	MITER GAUGE STOP
611	P1023411	POINTER
612	P1026612	MITER GAUGE SCALE
614	PRP14M	ROLL PIN 3 X 6
615	P1026615	MITER GAUGE HINGE PIN



Label Placement

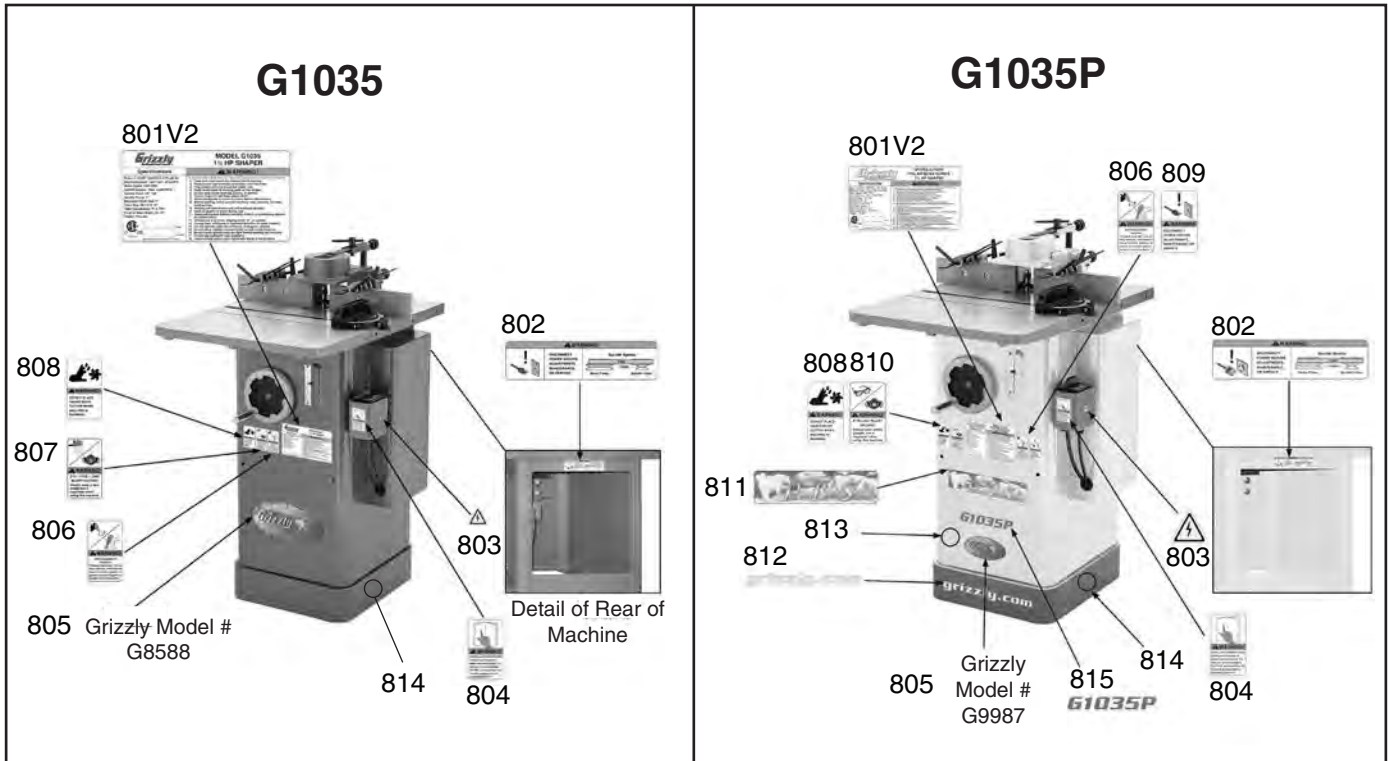

REF	PART #	DESCRIPTION
801V2	P1035801V2	MACHINE ID LABEL CSA V2.11.10 (G1035)
801V2	P1035P801V2	MACHINE ID LABEL CSA V2.03.11 (G1035P)
802	P1035802	BELT POSITION LABEL
803	PLABEL-14A	ELECTRICITY LABEL
804	PLABEL-12C	READ MANUAL LABEL
805	G8588	GRIZZLY NAMEPLATE (G1035)
805	G9987	GRIZZLY NAMEPLATE (G1035P)
806	PLABEL-55A	ENTANGLEMENT LABEL
807	PLABEL-56A	FACE SHELDT/RESPIRATOR LABEL

REF	PART #	DESCRIPTION
808	P1035808	AMPUTATION HAZARD LABEL 1.5 X 2.5
809	PLABEL-62A	DISCONNECT 110V POWER LABEL 1.5 X 2.5
810	PLABEL-57A	GLASSES/RESPIRATOR LABEL 1.5 X 2.5
811	PLABEL-75	POLAR BEAR LOGO 2-1/2 X 9-1/2
812	P0656P315	GRIZZLY.COM LABEL PB WHITE
813	PPAINT-24	POLAR BEAR WHITE TOUCH-UP PAINT
814	PPAINT-1	GRIZZLY GREEN TOUCH-UP PAINT
815	P1035P043	MODEL NUMBER LABEL

WARNING

Safety labels help reduce the risk of serious injury caused by machine hazards. If any label comes off or becomes unreadable, the owner of this machine **MUST** replace it in the original location before resuming operations. For replacements, contact (800) 523-4777 or www.grizzly.com.

