

SECTION 9: PARTS

We do our best to stock replacement parts when possible, but we cannot guarantee that all parts shown are available for purchase. Call (800) 523-4777 or visit www.grizzly.com/parts to check for availability.

Main

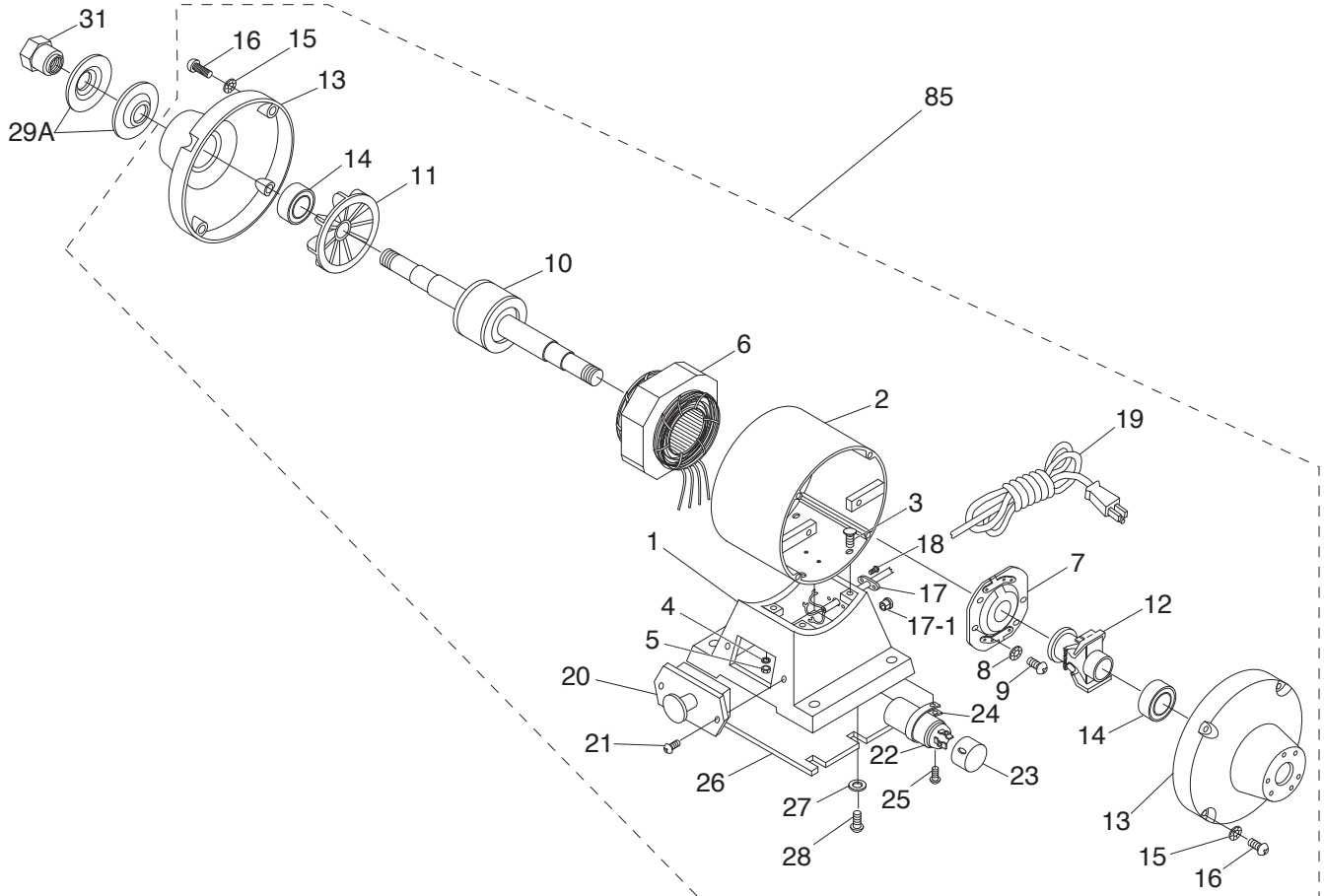

REF	PART #	DESCRIPTION
1	P1015001	BASE
2	P1015002	MOTOR CASE
3	P1015003	PHLP HD SCR 5/16-18 X 1-1/4
4	P1015004	LOCK WASHER 5/16
5	P1015005	HEX NUT 5/16-18
6	P1015006	STATOR WINDING
7	P1015007	CONTACT PLT, LG, INT PT
8	P1015008	LOCK WASHER 3/16
9	P1015009	PHLP HD SCR 10-24 X 1/2
10	P1015010	ROTOR/SHAFT
11	P1015011	FAN
12	P1015012	CENTRIFUGAL SWITCH
13	P1015013	END BELL
14	P1015014	BALL BEARING 6206ZZ
15	P1015015	LOCK WASHER 1/4
16	P1015016	PHLP HD SCR 1/4-20 X 5/8

REF	PART #	DESCRIPTION
17	P1015017	CORD CLAMP
17-1	P1015017-1	STRAIN RELIEF
18	P1015018	PHLP HD SCR 10-24 X 1-1/4
19	P1015019	POWER CORD 16GA/3W 73"L
20	P1015020	ON/OFF BUTTON
21	P1015021	PHLP HD SCR 10-24 X 1/2
22	P1015022	S CAPACITOR 400M 125V 1-3/4 X 3-3/8
23	P1015023	CAPACITOR COVER
24	P1015024	CAPACITOR CLAMP
25	P1015025	PHLP HD SCR 10-24 X 3/8
26	P1015026	COVER PLATE
27	P1015027	FLAT WASHER 1/4
28	P1015028	PHLP HD SCR 10-24 X 3/8
29A	P1015029A	WHEEL FLANGE 64.7 X 19.2 X 2.8MM
31	P1015031	ARBOR NUT 5/8-18 LH
85	P1015085	COMPLETE MOTOR ASSEMBLY



Sanding Assembly

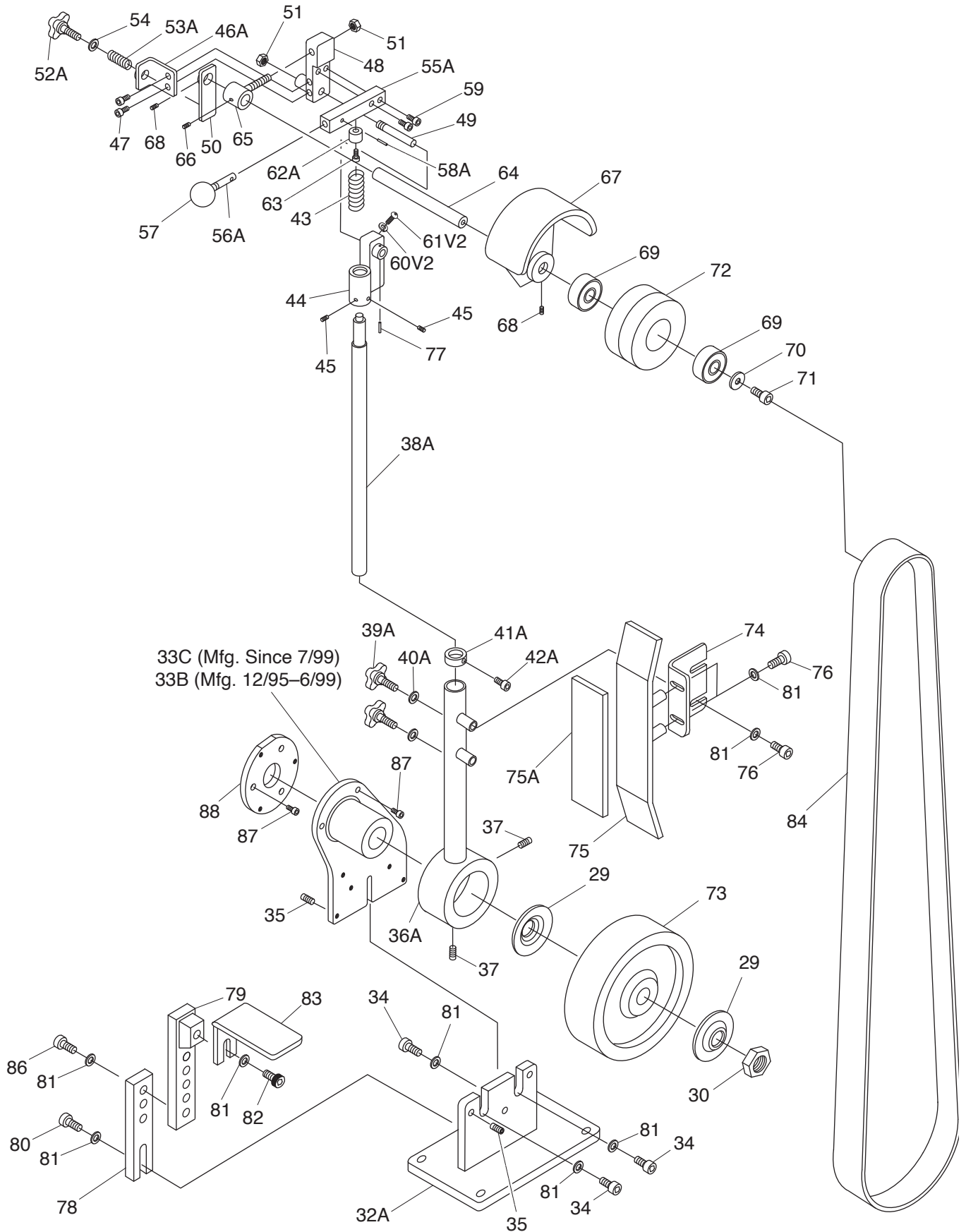

Sanding Assembly Parts List

REF PART #	DESCRIPTION
29	P1015029 WHEEL FLANGE 73.2 X 16.1 X 2.8MM
30	P1015030 HEX NUT 3/4-16
32A	P1015032A PIVOT ARM MOUNTING BRACKET
33B	P1015033B PIVOT BRACKET W/BUSHING V3.12.95
33C	P1015033C PIVOT BRACKET W/O BUSHING V4.07.99
34	P1015034 CAP SCREW 5/16-18 X 1
35	P1015035 SET SCREW 5/16-18 X 1/2
36A	P1015036A PIVOT ARM
37	P1015037 SET SCREW 3/8-16 X 1/2
38A	P1015038A SHAFT 1"
39A	P1015039A KNOB 3/8-16
40A	P1015040A FLAT WASHER 3/8
41A	P1015041A COLLAR FOR 1" SHAFT
42A	P1015042A CAP SCREW 1/4-28 x 5/8
43	P1015043 COMPRESSION SPRING D22.3 X 87MM
44	P1015044 UPPER SHAFT BRACKET
45	P1015045 SET SCREW 5/16-18 X 1/4
46A	P1015046A TRACKING BRACKET
47	P1015047 CAP SCREW 1/4-20 X 1/2
48	P1015048 PIVOT BRACKET
49	P1015049 SHAFT
50	P1015050 TRACKING LEVER
51	P1015051 LOCK NUT 3/8-16
52A	P1015052A TRACKING KNOB 1/2-20
53A	P1015053A COMPRESSION SPRING D18 X 56MM
54	P1015054 FLAT WASHER 1/2
55A	P1015055A TENSION BAR 4-1/8"
56A	P1015056A TENSION KNOB SHAFT
57	P1015057 TENSION KNOB 3/8-16
58A	P1015058A ROLL PIN 5 X 20

REF PART #	DESCRIPTION
59	P1015059 CAP SCREW 5/16-18 X 3/4
60V2	P1015060V2 LOCK WASHER 1/4 V2.10.24
61V2	P1015061V2 BUTTON HD CAP SCR 1/4-20 X 1/2 V2.10.24
62A	P1015062A SPRING BUSHING
63	P1015063 CAP SCREW 1/4-20 X 1
64	P1015064 AXLE
65	P1015065 PIVOT BUSHING
66	P1015066 SET SCREW 1/4-20 X 3/8
67	P1015067 WHEEL GUARD
68	P1015068 SET SCREW 5/16-18 X 1/4
69	P1015069 BALL BEARING 6204ZZ
70	P1015070 FLAT WASHER 1/4
71	P1015071 CAP SCREW 1/4-20 X 1/2
72	P1015072 IDLER WHEEL
73	P1015073 DRIVE WHEEL 8"
74	P1015074 PLATEN BRACKET
75	P1015075 PLATEN
75A	P1015075A GRAPHITE PAD 2"W X 9"L
76	P1015076 CAP SCREW 5/16-18 X 3/4
77	P1015077 ROLL PIN 1/8 X 1
78	P1015078 TOOL REST SUPPORT LEFT
79	P1015079 TOOL REST SUPPORT RIGHT
80	P1015080 CAP SCREW 5/16-18 X 1
81	P1015081 FLAT WASHER 5/16
82	P1015082 CAP SCREW 5/16-18 X 3/4
83	P1015083 TOOL REST
84	P1015084 SANDING BELT 2" X 72" 100GR
86	P1015086 CAP SCREW 5/16-18 X 1-1/4
87	P1015087 CAP SCREW 1/4-20 X 1/2
88	P1015088 MOUNTING ADAPTOR



Labels & Cosmetics

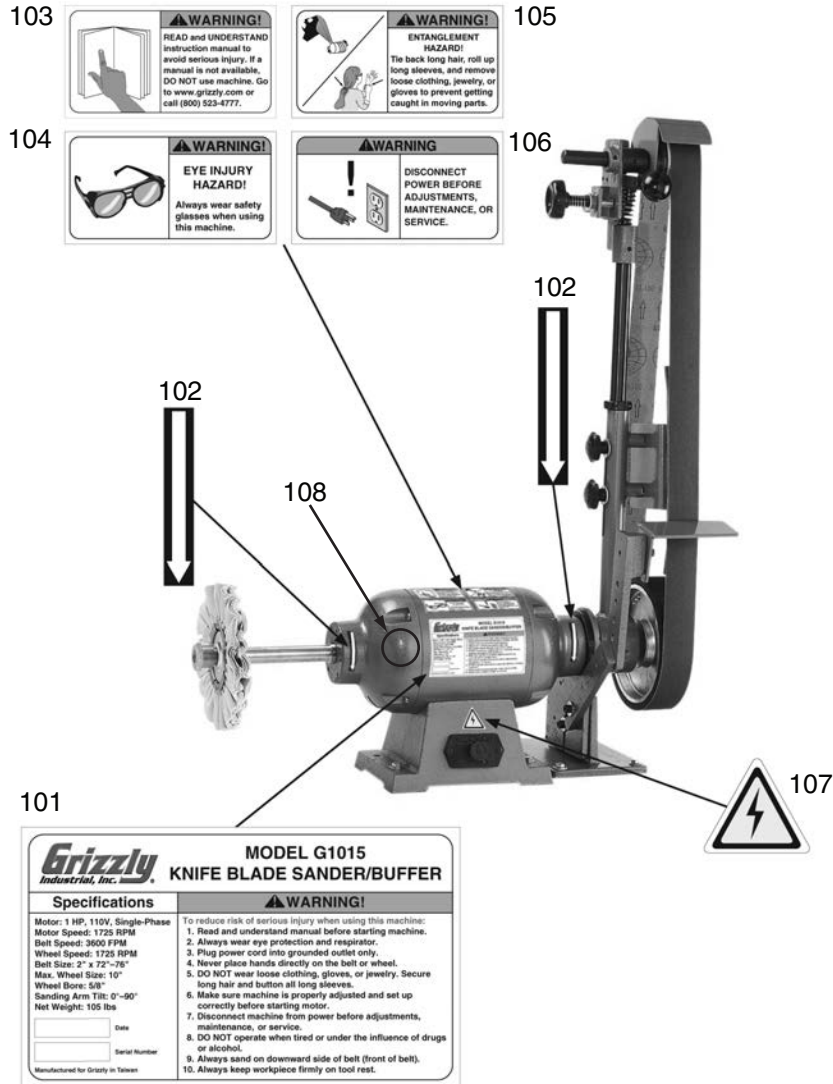

Grizzly Industrial, Inc.		MODEL G1015 KNIFE BLADE SANDER/BUFFER	
Specifications		WARNING!	
Motor: 1 HP, 110V, Single-Phase Motor Speed: 1725 RPM Belt Speed: 3600 FPM Wheel Speed: 1725 RPM Belt Size: 2" x 72" -76" Max. Wheel Size: 10" Wheel Bore: 5/8" Sanding Arm Tilt: 0°-90° Net Weight: 105 lbs		To reduce risk of serious injury when using this machine: 1. Read and understand manual before starting machine. 2. Always wear eye protection and respirator. 3. Plug power cord into grounded outlet only. 4. Never place hands directly on the belt or wheel. 5. DO NOT wear loose clothing, gloves, or jewelry. Secure long hair and button all long sleeves. 6. Make sure machine is properly adjusted and set up correctly before starting motor. 7. Disconnect machine from power before adjustments, maintenance, or service. 8. DO NOT operate when tired or under the influence of drugs or alcohol. 9. Always sand on downward side of belt (front of belt). 10. Always keep workpiece firmly on tool rest.	
Date	Serial Number		
Manufactured for Grizzly in Taiwan			

REF	PART #	DESCRIPTION
101	P1015101	MACHINE ID LABEL
102	P1015102	ROTATION DIRECTION LABEL
103	P1015103	READ MANUAL LABEL
104	P1015104	EYE INJURY HAZARD LABEL

REF	PART #	DESCRIPTION
105	P1015105	ENTANGLEMENT HAZARD LABEL
106	P1015106	DISCONNECT WARNING LABEL
107	P1015107	ELECTRICITY LABEL
108	P1015108	GRIZZLY GREEN TOUCH-UP PAINT

! WARNING

Safety labels help reduce the risk of serious injury caused by machine hazards. If any label comes off or becomes unreadable, the owner of this machine **MUST** replace it in the original location before resuming operations. For replacements, contact (800) 523-4777 or www.grizzly.com.

