

# Revised Parts Breakdown

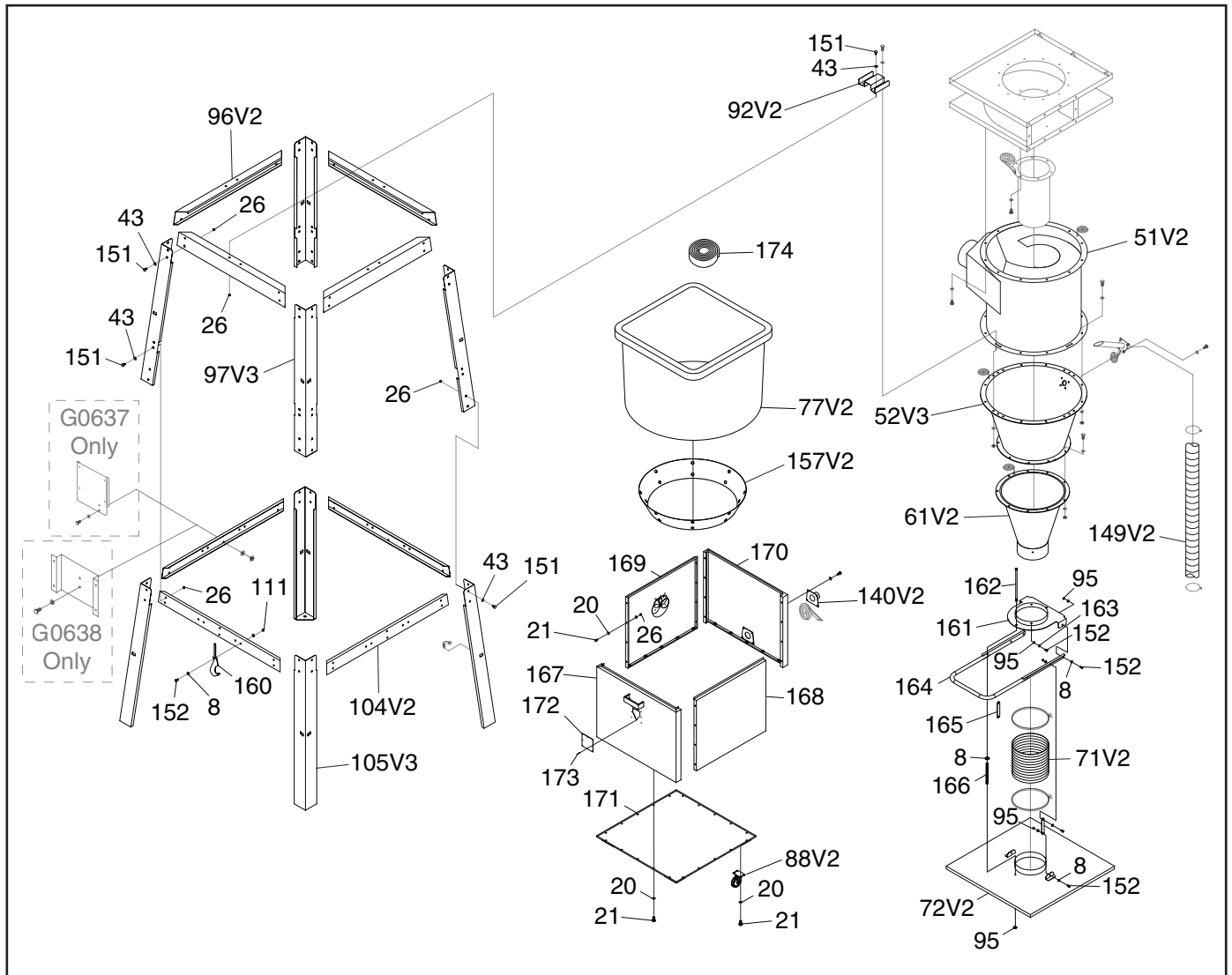

REF	PART #	DESCRIPTION
8	P0637008	FLAT WASHER 3/8
20	P0637020	FLAT WASHER 5/16
21	P0637021	HEX BOLT 5/16-18 X 3/4
26	P0637026	HEX NUT 5/16-18
43	P0637043	FLAT WASHER 5/16
51V2	P0637051V2	INTAKE BARREL V2.10.20
52V3	P0637052V3	LARGE CYCLONE FUNNEL V3.10.20
61V2	P0637061V2	SMALL CYCLONE FUNNEL V2.10.20
71V2	P0637071V2	FLEXIBLE DUCT 9 X 9-1/2" V2.10.20
72V2	P0637072V2	COLLECTION DRUM LID V2.10.20
77V2	P0637077V2	DRUM COLLECTION BAG 1.2 X 1.25M V2.10.20
88V2	P0637088V2	CASTER 4" V2.10.20
92V2	P0637092V2	CYCLONE MOUNTING BRACKET V2.10.20
95	P0637095	LOCK NUT 3/8-16
96V2	P0637096V2	UPPER STAND BRACE V2.10.20
97V3	P0637097V3	UPPER STAND LEG V3.10.20
104V2	P0637104V2	LOWER STAND BRACE V2.10.20
105V3	P0637105V3	LOWER STAND LEG V3.10.20
111	P0637111	LOCK NUT 3/8-16
140V2	P0637140V2	COLLECTION DRUM VACUUM TUBE V2.10.20

REF	PART #	DESCRIPTION
149V2	P0637149V2	VACUUM HOSE 2" X 118-1/8" V2.10.20
151	P0637151	CARRIAGE BOLT 5/16-18 X 3/4
152	P0637152	HEX BOLT 3/8-16 X 1
157V2	P0637157V2	COLLECTION DRUM VACUUM RING V2.10.20
160	P0637160	HANDLE HOOK
161	P0637161	CYCLONE FUNNEL ADAPTER
162	P0637162	HEX BOLT 3/8-16 X 11
163	P0637163	FLAT WASHER 3/8 THIN
164	P0637164	COLLECTION LID HANDLE
165	P0637165	DRUM LID CONNECTING PLATE
166	P0637166	DRUM LID SPRING
167	P0637167	FRONT DRUM PANEL
168	P0637168	LEFT DRUM PANEL
169	P0637169	RIGHT DRUM PANEL
170	P0637170	REAR DRUM PANEL
171	P0637171	BASE DRUM PANEL
172	P0637172	DRUM WINDOW
173	P0637173	RIVET
174	P0637174	DRUM LIP PVC SEAL 3100MM



# SECTION 10: PARTS

## Parts Breakdown

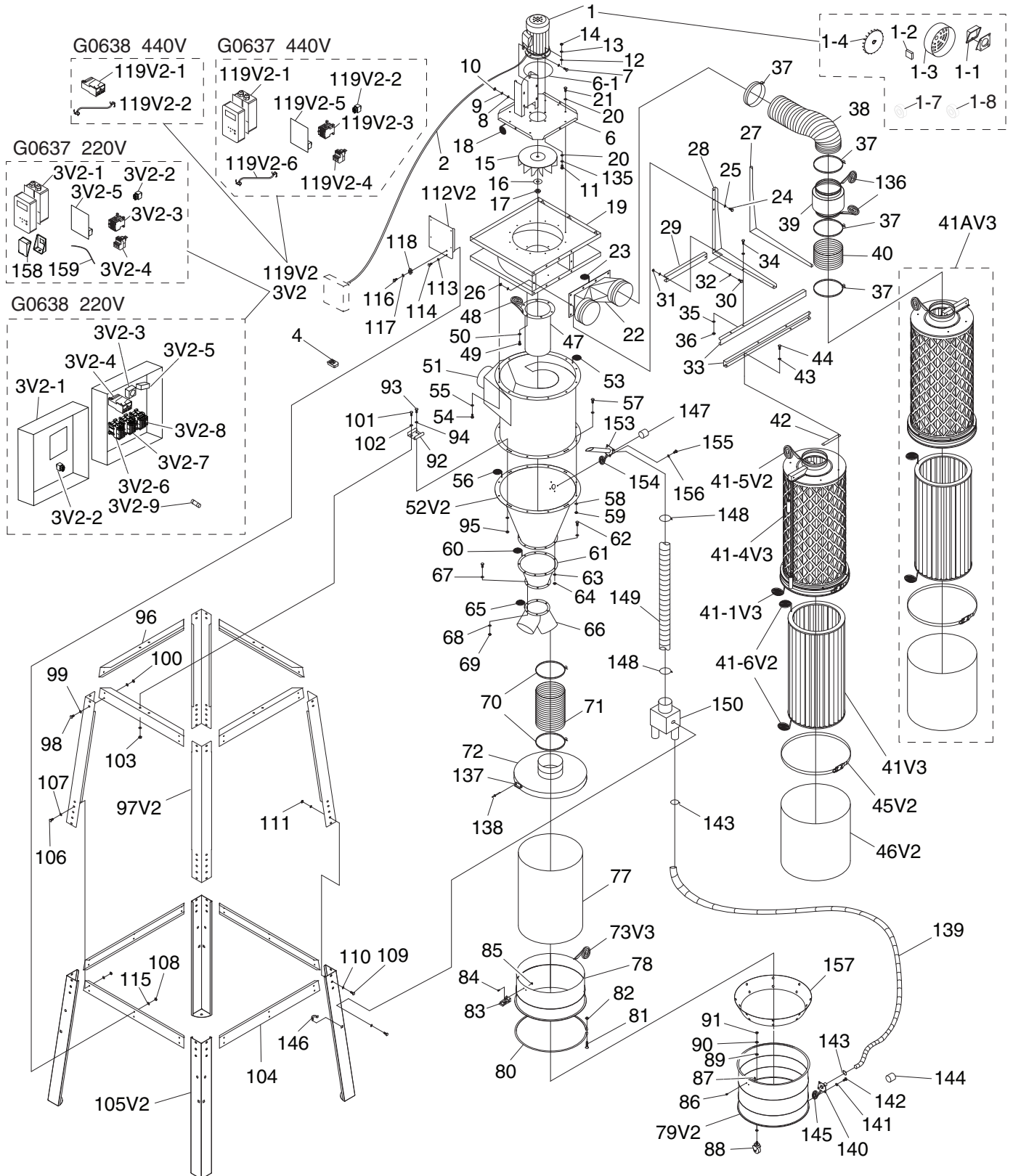

# G0637 Only Parts List

REF	PART #	DESCRIPTION
1	P0637001	MOTOR 7-1/2HP 220/440V 3-PH
1-1	P0637001-1	MOTOR JUNCTION BOX
1-2	P0637001-2	MOTOR JUNCTION BLOCK
1-3	P0637001-3	MOTOR FAN COVER
1-4	P0637001-4	MOTOR FAN
1-7	P0637001-7	FRONT MOTOR BEARING
1-8	P0637001-8	REAR MOTOR BEARING
2	P0637002	MOTOR CORD 10G 4W 300V
3V2	P0637003V2	MAG SWITCH ASSY V2.01.12
3V2-1	P0637003V2-1	MAGNETIC SWITCH COVER
3V2-2	P0637003V2-2	POWER SWITCH
3V2-3	P0637003V2-3	CONTACTOR NHD C-35D 220V
3V2-4	P0637003V2-4	OL RELAY NHD NTH-28 24-28A
3V2-5	P0637003V2-5	CIRCUIT BOARD W/TRANSFORMER
6	P0637006	MOTOR BASE
6-1	P0637006-1	MOTOR GASKET
15	P0637015	IMPELLER 18"
16	P0637016	FLAT WASHER 3/4

REF	PART #	DESCRIPTION
17	P0637017	HEX NUT 3/4-16 LH
41AV3	P0637041AV3	CANISTER ASSEMBLY, BEIGE V3.07.12
41V2	P0637041V2	CANISTER FILTER 486 X 1195MM V2.11.09
41-4V3	P0637041-4V3	CANISTER CAGE ASSY, BEIGE V3.07.12
112V2	P0637112V2	CONTROL BOX BRACKET CSA V2.01.12
116	P0637116	PHLP HD SCR 10-24 X 3/8
117	P0637117	FLAT WASHER #10
118	P0637118	HEX NUT 10-24
119V2	P0637119V2	CONVERSION KIT 440V V2.01.12
119V2-1	P0637119V2-1	MAGNETIC SWITCH COVER
119V2-2	P0637119V2-2	POWER SWITCH
119V2-3	P0637119V2-3	CONTACTOR MSN35-18D
119V2-4	P0637119V2-4	OL RELAY NHD NTH-15 10-15A
119V2-5	P0637119V2-5	CIRCUIT BOARD W/TRANSFORMER
119V2-6	P0637119V2-6	MOTOR CORD 12G 4W 600V
119V2-7	P0637119V2-7	SWITCH TRANSFORMER 30VA
158	P0637158	JUNCTION BOX
159	P0637159	GREEN GROUNDING WIRE 10G 6"

# G0638 Only Parts List

REF	PART #	DESCRIPTION
1	P0638001	MOTOR 10HP 220/440V 3-PH
1-1	P0638001-1	MOTOR JUNCTION BOX
1-2	P0638001-2	MOTOR JUNCTION BLOCK
1-3	P0638001-3	MOTOR FAN COVER
1-4	P0638001-4	MOTOR FAN
1-7	P0638001-7	FRONT MOTOR BEARING
1-8	P0638001-8	REAR MOTOR BEARING
2	P0638002	MOTOR CORD 12G 4W 300V
3V2	P0638003V2	CONTROL BOX 220V V2.01.12
3V2-1	P0638003V2-1	CONT. BOX W/ CIRC BOARD
3V2-2	P0638003V2-2	POWER SWITCH 220/440V
3V2-3	P0638003V2-3	START TIMER OMRON H3BG 0-12 SEC
3V2-4	P0638003V2-4	OL RELAY SHIHLIN TH-P20 28-38 220V
3V2-5	P0638003V2-5	TRANSFORMER
3V2-6	P0638003V2-6	CONTACTOR SHIHLIN S-P21
3V2-7	P0638003V2-7	CONTACTOR SHIHLIN S-P21

REF	PART #	DESCRIPTION
3V2-9	P0638003V2-9	FUSE 2AMP
6	P0638006	MOTOR BASE
6-1	P0638006-1	MOTOR GASKET
15	P0638015	IMPELLER 18-1/2"
16	PW19	FLAT WASHER 1-1/6
17	PN44	HEX NUT 1-1/16-8
41AV3	P0638041AV3	CANISTER ASSEMBLY, BEIGE V3.07.12
41V3	T24781	CANISTER ASSEMBLY FOR G0638
41-4V2	P0638041-4V2	CANISTER CAGE, GREEN V2.11.09
112V2	P0638112V2	CONT. BOX BRACKET CSA V2.01.12
116	PS11M	PHLP HD SCR M6-1 X 16
117	PW06	FLAT WASHER 1/4
118	PN01M	HEX NUT M6-1
119V2	P0638119V2	CONVERSION KIT 440V V2.01.12
119V2-1	P0638119V2-1	OL RELAY SHIHLIN/TH-P20S 12-18A
119V2-2	P0638119V2-2	MOTOR CORD 12G 4W 600V

# G0637/G0638 Common Parts List

REF	PART #	DESCRIPTION
4	P0637004	REMOTE CONTROLLER
7	P0637007	HEX BOLT 3/8-16 X 1-1/2
8	P0637008	FLAT WASHER 3/8
9	P0637009	LOCK WASHER 3/8
10	P0637010	HEX NUT 3/8-16
11	P0637011	HEX BOLT 1/2-13 X 1-1/2
12	P0637012	FLAT WASHER 1/2
13	P0637013	LOCK WASHER 1/2
14	P0637014	HEX NUT 1/2-13
18	P0637018	GASKET 3 X 6 X 1700MM

REF	PART #	DESCRIPTION
19	P0637019	BLOWER
20	P0637020	FLAT WASHER 5/16
21	P0637021	HEX BOLT 5/16-18 X 3/4
22	P0637022	OUTLET PORT
23	P0637023	FOAM TAPE 3 X 15 X 700MM
24	P0637024	HEX BOLT 5/16-18 X 1
25	P0637025	FLAT WASHER 5/16
26	P0637026	HEX NUT 5/16-18
27	P0637027	RIGHT FILTER L-BRACE



# G0637/G0638 Common Parts List

REF	PART #	DESCRIPTION
28	P0637028	LEFT FILTER L-BRACE
29	P0637029	SHORT FILTER BRACE SUPPORT
30	P0637030	HEX BOLT 3/8-16 X 3/4
31	P0637031	HEX NUT 3/8-16
32	P0637032	FLAT WASHER 3/8
33	P0637033	LONG FILTER BRACE SUPPORT
34	P0637034	HEX BOLT 3/8-16 X 3/4
35	P0637035	FLAT WASHER 3/8
36	P0637036	HEX NUT 3/8-16
37	P0637037	HOSE CLAMP 8"
38	P0637038	FLEXIBLE DUCT 8 X 31-1/2"
39	P0637039	NOISE MUFFLER 8"
40	P0637040	FLEXIBLE DUCT 8 X 4-3/4"
41-1V2	P0637041-1V2	GASKET 3 X 25 X 1700MM V2.11.09
41-5V2	P0637041-5V2	FOAM TAPE 3 X 25 X 700MM V2.11.09
41-6V2	P0637041-6V2	GASKET 35 X 38 X 1570MM V2.11.09
42	P0637042	RUBBER BRACE GASKET
43	P0637043	FLAT WASHER 5/16
44	P0637044	HEX BOLT 5/16-18 X 3/4
45V2	P0637045V2	FILTER BAG CLAMP 545MM V2.11.09
46V2	P0637046V2	COLLECTION BAG 570 X 600MM V2.11.09
47	P0637047	INTAKE CYLINDER
48	P0637048	GASKET 3 X 6 X 1800MM
49	P0637049	HEX BOLT 5/16-18 X 3/4
50	P0637050	FLAT WASHER 5/16
51	P0637051	INTAKE BARREL
52V2	P0637052V2	LARGE CYCLONE FUNNEL V2.08.10
53	P0637053	GASKET 3 X 6 X 2500MM
54	P0637054	HEX BOLT 5/16-18 X 3/4
55	P0637055	FLAT WASHER 5/16
56	P0637056	GASKET 3 X 6 X 2500MM
57	P0637057	HEX BOLT 5/16-18 X 1-1/4
58	P0637058	FLAT WASHER 5/16
59	P0637059	HEX NUT 5/16-18
60	P0637060	GASKET 3 X 6 X 2200MM
61	P0637061	SMALL CYCLONE FUNNEL
62	P0637062	HEX BOLT 5/16-18 X 1-1/4
63	P0637063	FLAT WASHER 5/16
64	P0637064	HEX NUT 5/16-18
65	P0637065	GASKET 3 X 6 X 735MM
66	P0637066	FUNNEL PORT
67	P0637067	HEX BOLT 5/16-18 X 1-1/4
68	P0637068	FLAT WASHER 5/16
69	P0637069	HEX NUT 5/16-18
70	P0637070	HOSE CLAMP 9"
71	P0637071	FLEXIBLE DUCT 9 X 25-1/2"
72	P0637072	COLLECTION DRUM LID
73V3	P0637073V3	DRUM SEAL TYPE-R 2.1M V3.01.12
77	P0637077	DRUM COLLECTION BAG 640 X 1200MM
78	P0637078	UPPER DRUM 25GAL
79V2	P0637079V2	COLLECTION DRUM 35GAL V2.08.10
80	P0637080	DRUM CLAMP
81	P0637081	HEX BOLT 5/16-18 X 3
82	P0637082	HEX NUT 5/16-18
83	P0637083	COLLECTION DRUM LID LATCH

REF	PART #	DESCRIPTION
84	P0637084	PHLP HD SCR 10-24 X 3/8
85	P0637085	HEX NUT 10-24
86	P0637086	PHLP HD SCR 10-24 X 3/8
87	P0637087	HEX NUT 10-24
88	P0637088	CASTER 2"
89	P0637089	FLAT WASHER 3/8
90	P0637090	LOCK WASHER 3/8
91	P0637091	HEX NUT 3/8-16
92	P0637092	CYCLONE MOUNTING BRACKET
93	P0637093	HEX BOLT 3/8-16 X 1-1/4
94	P0637094	FLAT WASHER 3/8
95	P0637095	LOCK NUT 3/8-16
96	P0637096	UPPER STAND BRACE
97V2	P0637097V2	UPPER STAND LEG V2.08.10
98	P0637098	HEX BOLT 3/8-16 X 3/4
99	P0637099	FLAT WASHER 3/8
100	P0637100	LOCK NUT 3/8-16
101	P0637101	HEX BOLT 3/8-16 X 3/4
102	P0637102	FLAT WASHER 3/8
103	P0637103	LOCK NUT 3/8-16
104	P0637104	LOWER STAND BRACE
105V2	P0637105V2	LOWER STAND LEG V2.08.10
106	P0637106	HEX BOLT 3/8-16 X 3/4
107	P0637107	FLAT WASHER 3/8
108	P0637108	LOCK NUT 3/8-16
109	P0637109	HEX BOLT 3/8-16 X 3/4
110	P0637110	FLAT WASHER 3/8
111	P0637111	LOCK NUT 3/8-16
113	P0637113	HEX BOLT 3/8-16 X 3/4
114	P0637114	FLAT WASHER 3/8
115	P0637115	HEX NUT 3/8-16
135	P0637135	EXT TOOTH WASHER 1/2
136	P0637136	FOAM TAPE 3 X 15 X 700MM
137	P0637137	DRUM LID HOOK
138	P0637138	HOOK RIVET
139	P0637139	VACUUM HOSE 1-1/4" X 79"
140	P0637140	COLLECTION DRUM VACUUM PORT
141	P0637141	FLAT WASHER 5/16
142	P0637142	HEX BOLT 5/16-18 X 3/4
143	P0637143	HOSE CLAMP 1-1/4"
144	P0637144	PORT PLUG 1-1/4"
145	P0637145	FOAM TAPE 3 X 6 X 300MM
146	P0637146	VACUUM HOSE CLIP 2-1/2"
147	P0637147	PORT PLUG 2"
148	P0637148	HOSE CLAMP 2"
149	P0637149	VACUUM HOSE 2" X 39"
150	P0637150	VACUUM MANIFOLD
153	P0637153	CYCLONE VACUUM PORT
154	P0637154	FOAM TAPE 3 X 6 X 300MM
155	P0637155	HEX BOLT 5/16-18 X 3/4
156	P0637156	FLAT WASHER 5/16
157	P0637157	COLLECTION DRUM VACUUM RING
158	P0637158	JUNCTION BOX
159	P0637159	GREEN GROUNDING WIRE 10G 6"



# Machine Labels

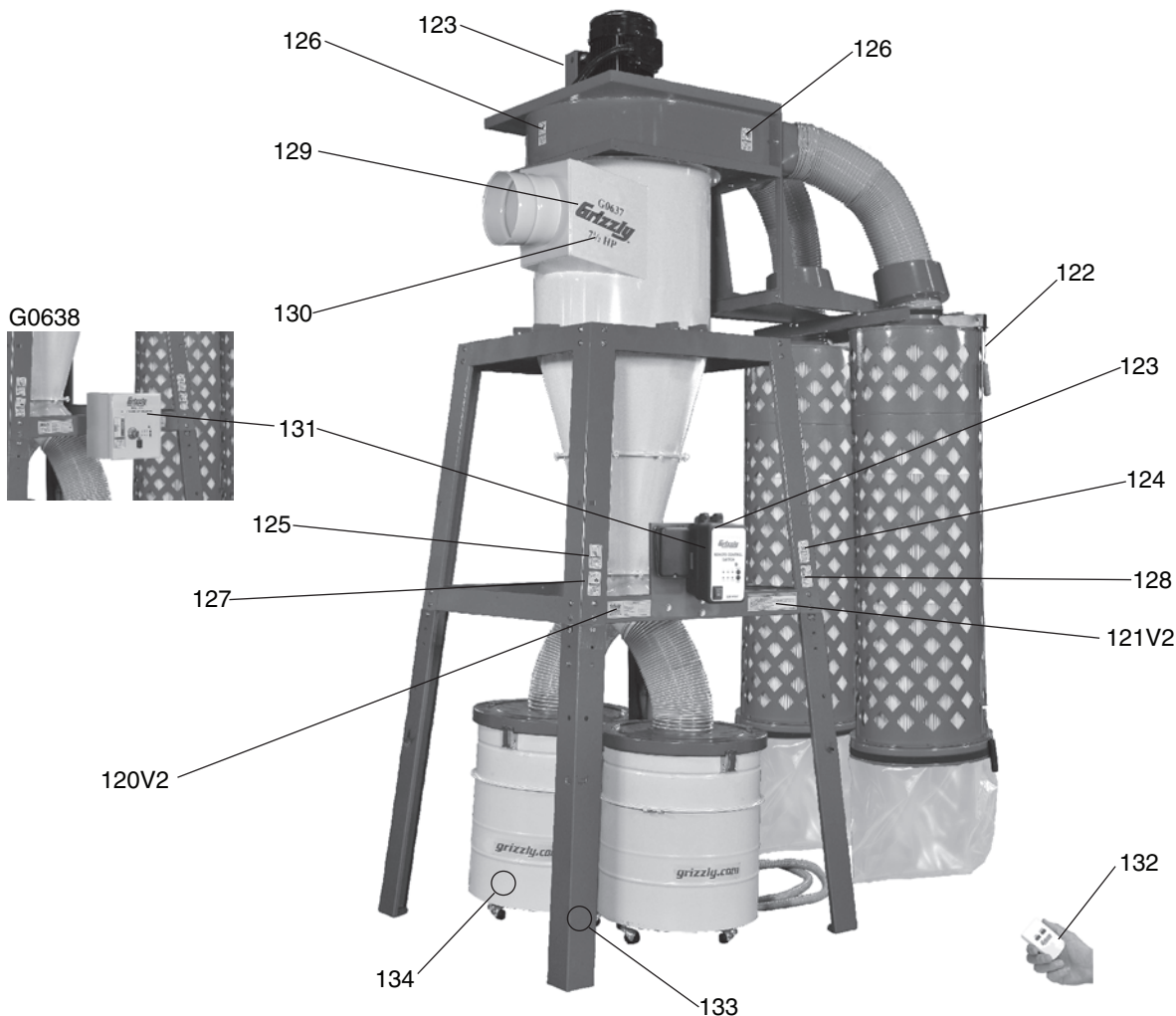

REF	PART #	DESCRIPTION
120V2	P0637120V2	MACHINE ID LABEL CSA V2.01.12
121V2	P0637121V2	GENERAL WARNING LABEL CSA V2.01.12
122	P0637122	RED HANDLE NOTICE LABEL
123	P0637123	ELECTRICITY LABEL
124	P0637124	DISCONNECT POWER LABEL
125	P0637125	READ MANUAL LABEL
126	P0637126	HANDS/OUTLET LABEL
127	P0637127	GLASSES/RESPIRATOR DC LABEL

REF	PART #	DESCRIPTION
128	P0637128	EAR PROTECTION LABEL
129	P0637129	MODEL NUMBER LABEL
130	P0637130	HORSEPOWER LABEL
131	P0637131	CONTROL PANEL LABEL
132	P0637132	REMOTE CONTROL LABEL
133	P0637133	TOUCH-UP PAINT, GRIZZLY GREEN
134	P0637134	TOUCH-UP PAINT, GRIZZLY PUTTY

## WARNING

Safety labels help reduce the risk of serious injury caused by machine hazards. If any label comes off or becomes unreadable, the owner of this machine **MUST** replace it in the original location before resuming operations. For replacements, contact (800) 523-4777 or [www.grizzly.com](http://www.grizzly.com).

