

SECTION 9: PARTS

Main Parts List

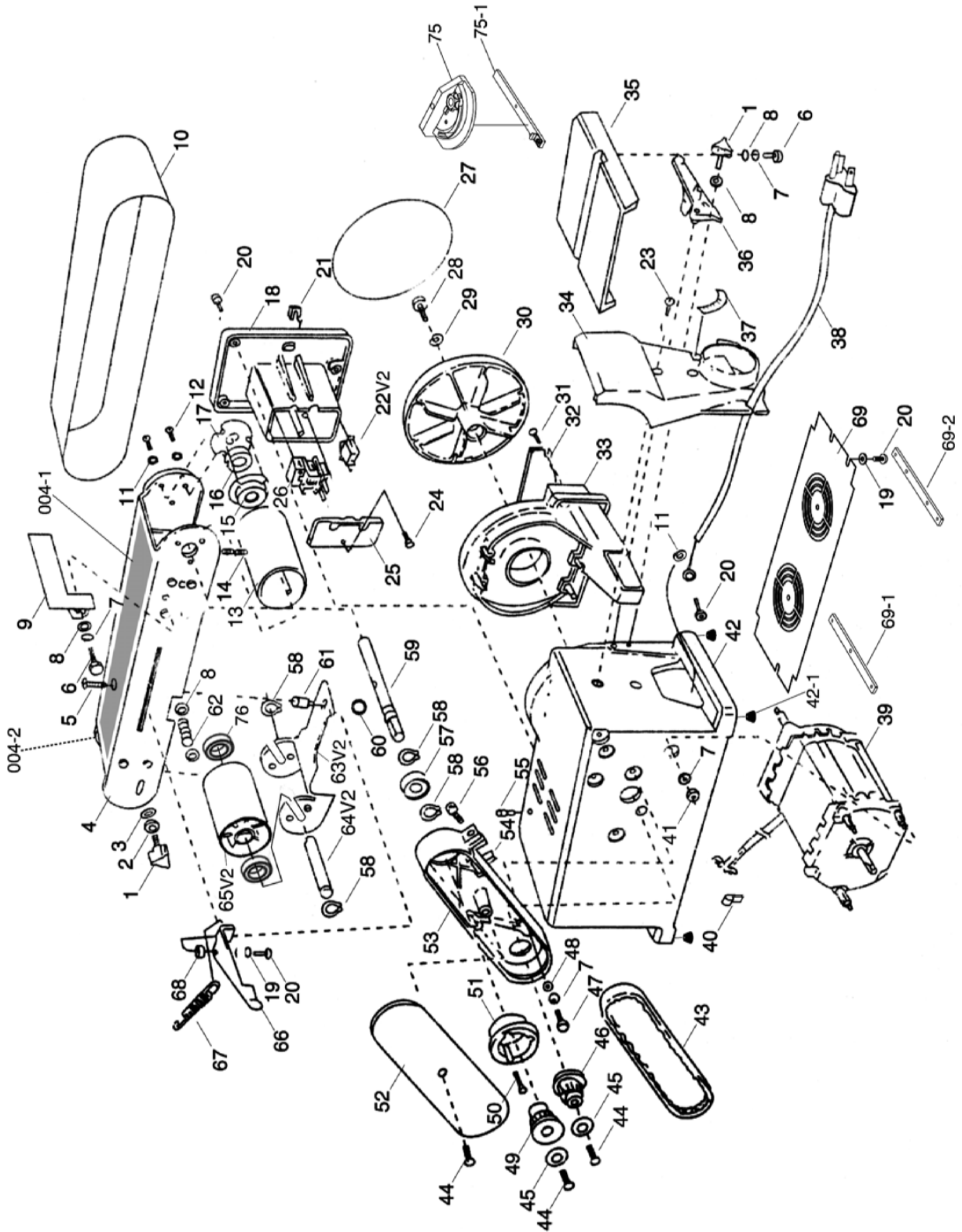

Main Breakdown

REF	PART #	DESCRIPTION
1	P0547001	KNOB M6-1 X 30 (MALE)
2	P0547002	RUBBER WASHER 7-16 X 1.7
3	P0547003	NOTCHED WASHER 7-19
4	P0547004	BED
4-1	P0547004-1	GRAPHITE PAD 4-3/8 X 12-1/4"
4-2	P0547004-2	TENSION RELEASE SPRING
5	P0547005	PHLP HD SCR M5-.8 X 35
6	P0547006	HEX BOLT M6-1 X 12
7	P0547007	LOCK WASHER 6MM
8	P0547008	FLAT WASHER 6MM
9	P0547009	BACK STOP
10	P0547010	SANDING BELT 4" X 36"
11	P0547011	LOCK WASHER 5MM
12	P0547012	PHLP HD SCR M5-.8 X 10
13	P0547013	DRIVE DRUM
14	P0547014	SET SCREW M8-1.25 X 10
15	P0547015	BEARING CAP
16	P0547016	BALL BEARING 6001ZZ
17	P0547017	BEARING SPACER
18	P0547018	SWITCH HOUSING
19	P0547019	FLAT WASHER 5MM
20	P0547020	PHLP HD SCR M5-.8 X 8
21	P0547021	YELLOW SWITCH KEY
22	P0547022V2	LOCKING SWITCH V2
23	P0547023	PHLP HD SCR M5-.8 X 20
24	P0547024	TAP SCREW M4 X 25
25	P0547025	SWITCH BOX COVER
26	P0547026	RELAY 110V (ALL WIN)
27	P0547027	6" PSA SANDPAPER DISC
28	P0547028	CAP SCREW M6-1 X 12
29	P0547029	LOCK WASHER 6MM
30	P0547030	DISC
31	P0547031	TAP SCR M4 X 8
32	P0547032	DISC GUARD
33	P0547033	DISC SHROUD
34	P0547034	DUST COLLECTOR
35	P0547035	DISC TABLE
36	P0547036	TABLE SUPPORT
37	P0547037	ANGLE MEASUREMENT LABEL

REF	PART #	DESCRIPTION
38	P0547038	CORD WITH PLUG
39	P0547039	MOTOR 1/3HP 110V 1PH
40	P0547040	WIRE HANGER
41	P0547041	HEX NUT M6-1
42	P0547042	BASE
42-1	P0547042-1	THREADED RUBBER FOOT
43	P0547043	DRIVE BELT 142XL037
44	P0547044	FLAT HD SCR M5-.8 X 10
45	P0547045	COUNTERSUNK WASHER 5MM
46	P0547046	MOTOR PULLEY 15MM BORE
47	P0547047	PHLP HD SCR M6-1 X 25
48	P0547048	FLAT WASHER 6MM
49	P0547049	ARBOR PULLEY 12MM BORE
50	P0547050	FLAT HD SCR M5-.8 X 25
51	P0547051	BEARING HOUSING
52	P0547052	BELT COVER
53	P0547053	BED SUPPORT
54	P0547054	SQUARE NUT M8-1.25
55	P0547055	RUBBER BUMPER
56	P0547056	CAP SCREW M8-1.25 X 25
57	P0547057	BALL BEARING 6001ZZ
58	P0547058	EXT RETAINING RING 12MM
59	P0547059	DRIVE SHAFT
60	P0547060	FLANGE NUT M5-.8
61	P0547061	GUIDE SPACER
62	P0547062	INDEX SPRING 1 X 33.5
63V2	P0547063V2	GUIDE DRUM V2.11.15
64V2	P0547064V2	IDLER SHAFT V2.11.15
65V2	P0547065V2	IDLER DRUM V2.11.15
66	P0547066	TENSION LEVER
67	P0547067	TENSION SPRING 2.5 X 77
68	P0547068	LEVER SPACER
69	P0547069	BOTTOM COVER PLATE
69-1	P0547069-1	COVER PLATE BRKT LEFT 1-HOLE
69-2	P0547069-2	COVER PLATE BRKT RIGHT 2-HOLE
75	P0547075	COMPLETE MITER GAUGE
75-1	P0547075-1	MITER BODY
76	P0547076	BALL BEARING P6001-2RS



Labels & Cosmetics

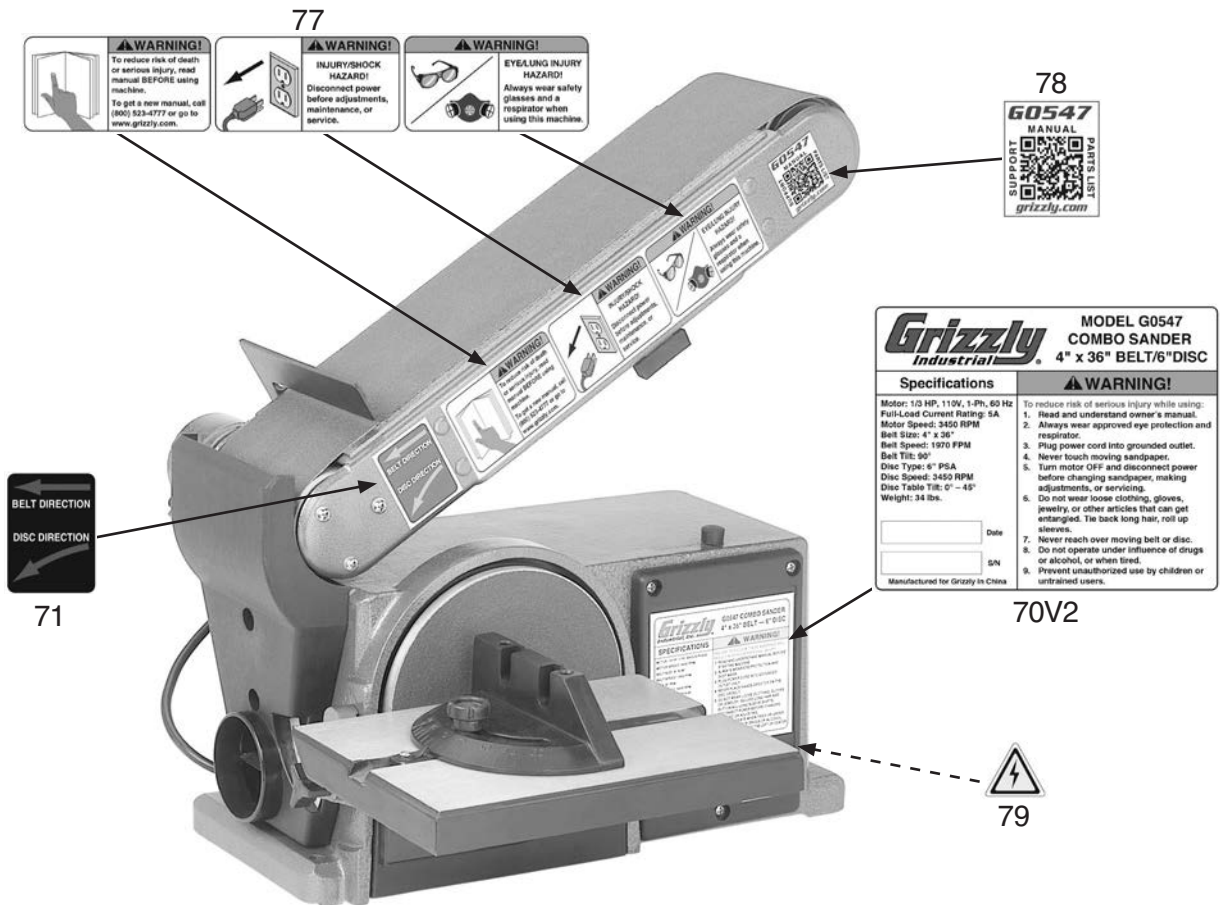

REF	PART #	DESCRIPTION
70V2	P0547070V2	WARNING-ID LABEL V2
71	P0547071	LABEL-BELT DIRECTION
77	P0547077	WARNING LABEL COMBO
78	P0547078	QR CODE
79	P0547079	ELECTRICITY LABEL

Grizzly Industrial MODEL G0547 COMBO SANDER 4" x 36" BELT/6" DISC

Specifications	WARNING!
Motor: 1/2 HP, 110V, 1-Ph, 60 Hz Full-Load Current Rating: 5A Motor Speed: 3450 RPM Belt Size: 4" x 36" Belt Speed: 1970 FPM Belt Tilt: 90° Disc Type: 6" PSA Disc Speed: 3450 RPM Disc Table Tilt: 0° - 45° Weight: 34 lbs.	To reduce risk of serious injury while using: 1. Read and understand owner's manual. 2. Always wear approved eye protection and respirator. 3. Plug power cord into grounded outlet. 4. Never touch moving sandpaper. 5. Turn motor OFF and disconnect power before changing sandpaper, making adjustments, or servicing. 6. Do not wear loose clothing, gloves, jewelry, or other articles that can get entangled. Tie back long hair; roll up sleeves. 7. Never reach over moving belt or disc. 8. Do not operate under influence of drugs or alcohol, or when tired. 9. Prevent unauthorized use by children or untrained users.
_____ Date _____ SN	
Manufactured for Grizzly in China	

⚠ WARNING

Safety labels help reduce the risk of serious injury caused by machine hazards. If any label comes off or becomes unreadable, the owner of this machine **MUST** replace it in the original location before resuming operations. For replacements, contact (800) 523-4777 or www.grizzly.com.

