

Main Parts Breakdown

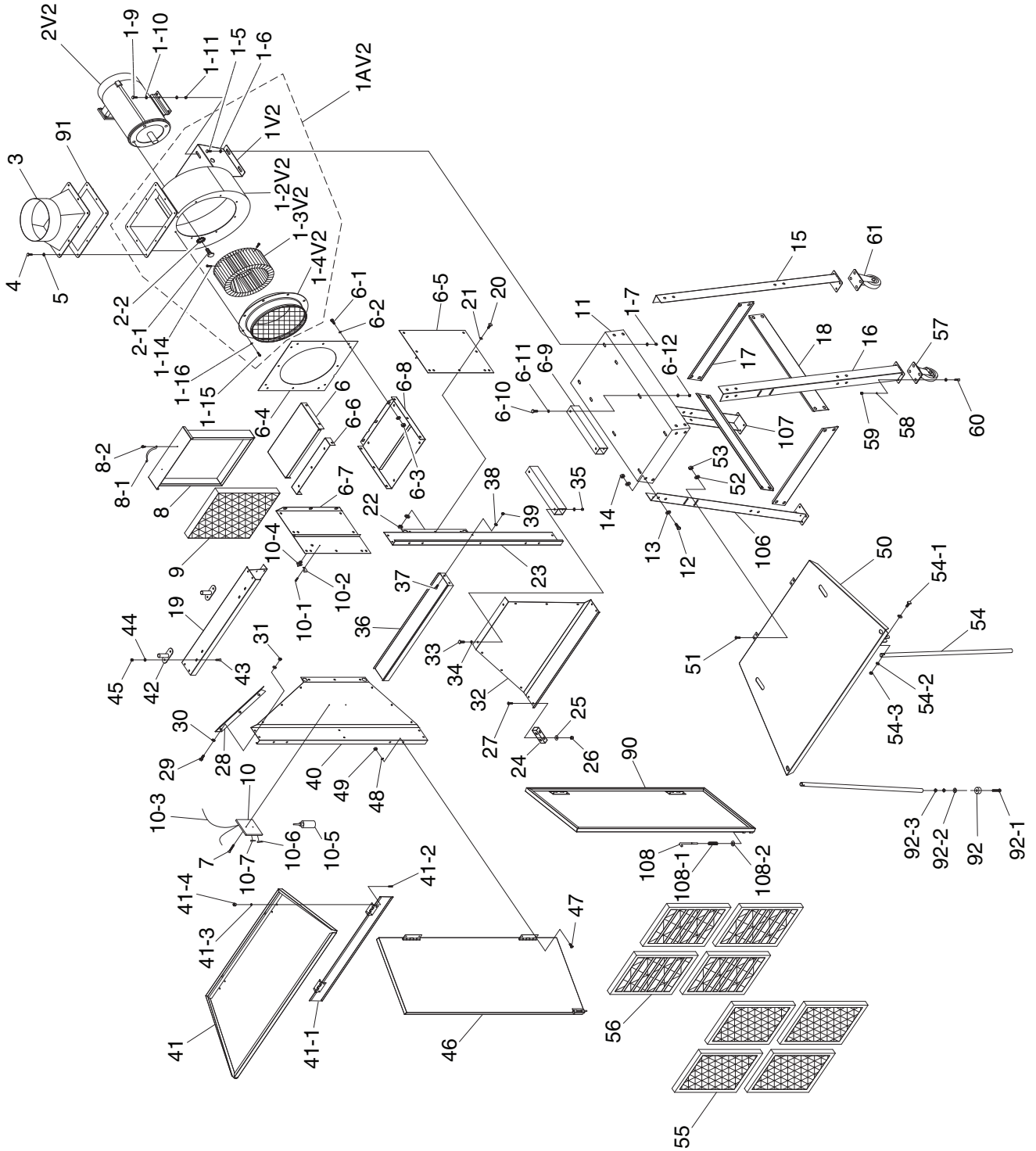

Main Parts List

REF	PART #	DESCRIPTION
1AV2	P0532001AV2	BLOWER HOUSING ASSEMBLY
1V2	P0532001V2	MOTOR SUPPORT BASE V2.03.11
1-2V2	P0532001-2V2	EXHAUST FAN HOUSING V2.03.11
1-3V2	P0532001-3V2	IMPELLER V2.03.11
1-4V2	P0532001-4V2	INTAKE PORT V2.03.11
1-5	PB21	HEX BOLT 3/8-16 X 3/4
1-6	PW02	FLAT WASHER 3/8
1-7	PN08	HEX NUT 3/8-16
1-9	PB21	HEX BOLT 3/8-16 X 3/4
1-10	PW02	FLAT WASHER 3/8
1-11	PN08	HEX NUT 3/8-16
1-14	PB21	HEX BOLT 3/8-16 X 3/4
1-15	PB07	HEX BOLT 5/16-18 X 3/4
1-16	PW07	FLAT WASHER 5/16
2V2	P0532002V2	MOTOR 2HP 115/230V T2C V2.03.11
2-1	PB52	HEX BOLT 1/2-13 X 1
2-2	PTLW04	EXT TOOTH WASHER 1/2
3	P0532003	OUTLET 10"
4	PB07	HEX BOLT 5/16-18 X 3/4
5	PW07	FLAT WASHER 5/16
6	P0532006	FILTER BOX COVER LARGE
6-1	PB07	HEX BOLT 5/16-18 X 3/4
6-2	PW07	FLAT WASHER 5/16
6-3	PN02	HEX NUT 5/16-18
6-4	P0532006-4	BACK FILTER BOX BOARD
6-5	P0532006-5	RIGHT FILTER BOX BOARD
6-6	P0532006-6	SMALL FILTER BOX COVER
6-7	P0532006-7	LEFT FILTER BOX BOARD
6-8	P0532006-8	FILTER BOX BOARD BASE
6-9	P0532006-9	FILTER BOX BASE
6-10	PB60	HEX BOLT 3/8-16 X 3
6-11	PW02	FLAT WASHER 3/8
6-12	PN08	HEX NUT 3/8-16
7	PHTEK46M	TAP SCREW M4 X 45
8	P0532008	FILTER DRAWER
8-1	P0532008-1	DRAWER HANDLE
8-2	PS37M	PHLP HD SCR M6-1 X 6
9	P0532009	5 MICRON THIRD STAGE FILTER
10	P0532010	AIR FILTER INDICATOR
10-1	PHTEK39M	TAP SCREW M4 X 12
10-2	P0532010-2	CLIP PLASTIC
10-3	P0532010-3	TUBING
10-4	P0532010-4	TUBE CONNECTOR FITTING
10-5	P0532010-5	RED GAUGE OIL
10-6	P0532010-6	GREEN ARROW LABEL
10-7	P0532010-7	RED ARROW LABEL
11	P0532011	EXHAUST FAN BASE
12	PB21	HEX BOLT 3/8-16 X 3/4
13	PW02	FLAT WASHER 3/8
14	PN08	HEX NUT 3/8-16
15	P0532015	RIGHT REAR LEG
16	P0532016	RIGHT FRONT LEG
17	P0532017	SHORT LEG SUPPORT
18	P0532018	LONG LEG SUPPORT
19	P0532019	UPPER SKEW BOARD
20	PB07	HEX BOLT 5/16-18 X 3/4
21	PW07	FLAT WASHER 5/16
22	PN02	HEX NUT 5/16-18

REF	PART #	DESCRIPTION
23	P0532023	RIGHT SKEW BOARD
24	P0532024	SMALL BRACE
25	PW06	FLAT WASHER 1/4
26	PN05	HEX NUT 1/4-20
27	PFH04	FLAT HD SCR 1/4-20 X 5/8
28	P0532028	LARGE PLATE
29	PB19	HEX BOLT 1/4-20 X 1/2
30	PW06	FLAT WASHER 1/4
31	PN05	HEX NUT 1/4-20
32	P0532032	LOWER SKEW BOARD
33	PB04	HEX BOLT 5/16-18 X 3
34	PW07	FLAT WASHER 5/16
35	PN02	HEX NUT 5/16-18
36	P0532036	MIDDLE BRACE
37	PFH04	FLAT HD SCR 1/4-20 X 5/8
38	PW06	FLAT WASHER 1/4
39	PN05	HEX NUT 1/4-20
40	P0532040	LEFT SKEW BOARD
41	P0532041	TOP LARGE CURTAIN STEEL
41-1	P0532041-1	TOP SMALL CURTAIN
41-2	PFH03	FLAT HD SCR 1/4-20 X 1/2
41-3	PW06	FLAT WASHER 1/4
41-4	PN05	HEX NUT 1/4-20
42	P0532042	CURTAIN BRACE
43	PFH04	FLAT HD SCR 1/4-20 X 5/8
44	PW06	FLAT WASHER 1/4
45	PN05	HEX NUT 1/4-20
46	P0532046	LEFT CURTAIN STEEL
47	PFH04	FLAT HD SCR 1/4-20 X 5/8
48	PW06	FLAT WASHER 1/4
49	PN05	HEX NUT 1/4-20
50	P0532050	WORK TABLE
51	PFH04	FLAT HD SCR 1/4-20 X 5/8
52	PW06	FLAT WASHER 1/4
53	PN05	HEX NUT 1/4-20
54	P0532054	WORK TABLE LEG
54-1	PB06	HEX BOLT 5/16-18 X 2
54-2	PW07	FLAT WASHER 5/16
54-3	PN02	HEX NUT 5/16-18
55	H5837	30 MICRON FIRST STAGE FILTER
56	H5838	10 MICRON SECOND STAGE FILTER
57	P0532057	SWIVEL CASTER 3"
58	PW07	FLAT WASHER 5/16
59	PN02	HEX NUT 5/16-18
60	PB07	HEX BOLT 5/16-18 X 3/4
61	P0532061	FIXED CASTER 3"
90	P0532090	RIGHT CURTAIN STEEL
91	P0532091	OUTLET GASKET
92	P0532092	LEG CUSHION
92-1	PB60	HEX BOLT 3/8-16 X 3
92-2	PW02	FLAT WASHER 3/8
92-3	PN08	HEX NUT 3/8-16
106	P0532106	LEFT FRONT LEG
107	P0532107	LEFT REAR LEG
108	P0532108	DOOR LATCH PIN
108-1	P0532108-1	COMPRESSION SPRING
108-2	P0532108-2	SPRING RETAINER



Safety Label Placement and Parts List

⚠️ WARNING

Safety labels help reduce the risk of serious injury caused by machine hazards. If any label comes off or becomes unreadable, the owner of this machine **MUST** replace it in the original location before resuming operations. For replacements, contact (800) 523-4777 or www.grizzly.com.

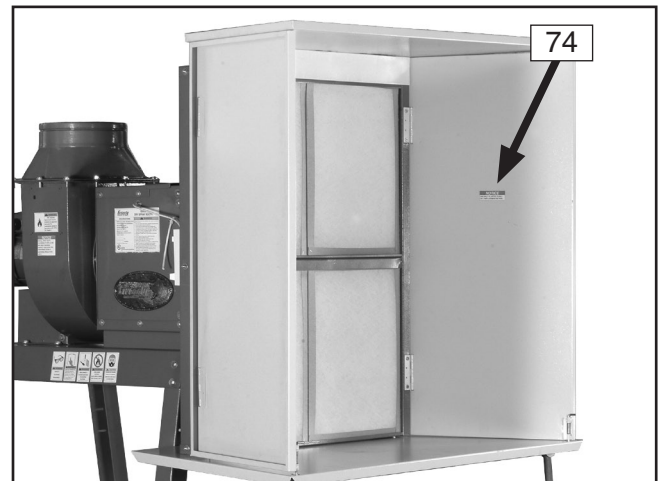
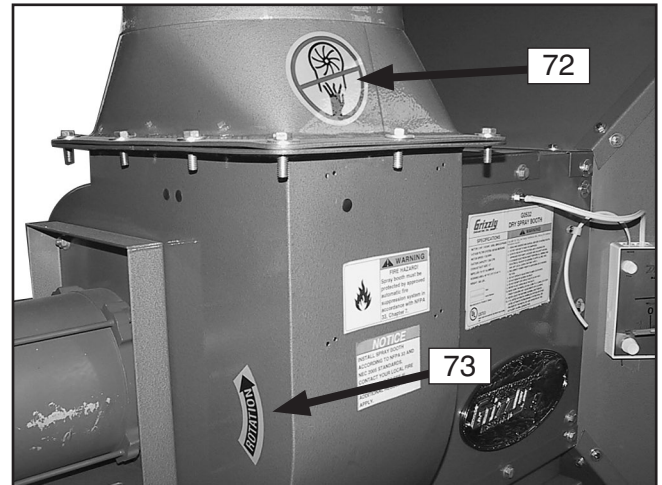
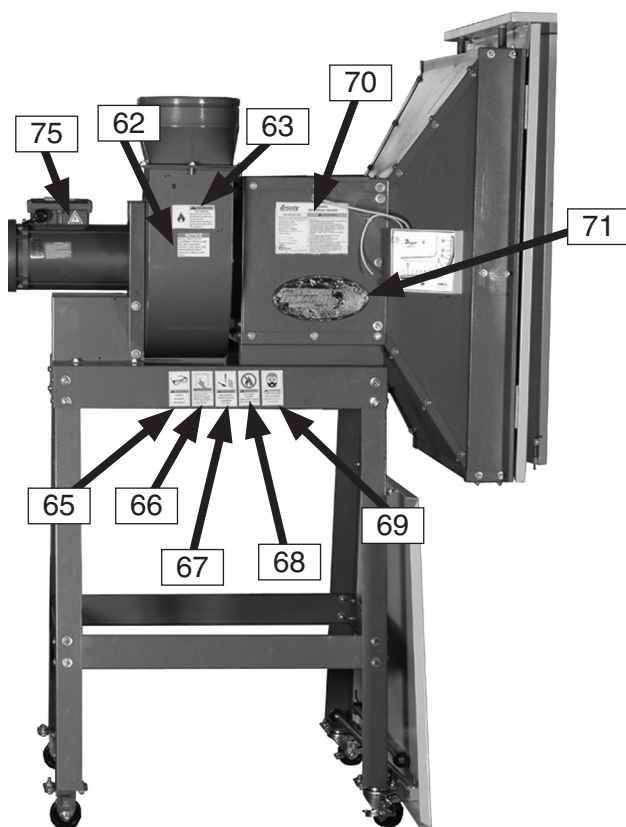

REF	PART #	DESCRIPTION
62	P0532062	NOTICE REGULATIONS LABEL
63	P0532063	FIRE HAZARD LABEL
65	PLABEL-11	SAFETY GLASSES LABEL
66	PLABEL-12A	READ MANUAL LABEL
67	P0532067	UNPLUG FILTER CHANGE LABEL
68	P0532068	EXPLOSION HAZARD LABEL
69	PLABEL-15	EAR PROTECTION LABEL

REF	PART #	DESCRIPTION
70	P0532070	MACHINE ID LABEL
71	G8588	GRIZZLY NAMEPLATE- SMALL
72	P0532072	IMPELLER HAZARD LABEL
73	P0532073	ROTATION DIRECTION LABEL
74	P0532074	NOTICE FILTERS LABEL
75	PLABEL-14	ELECTRICITY LABEL

