

REF	PART #	DESCRIPTION
1	X1693001	CREAM COLOR PAINT
2	XPN01	HEX NUT 1/2-20
3	XPN05	HEX NUT 1/4-20
4	XPB25	HEX BOLT 3/8-16 X 1-3/4
5	X1693005	DEPTH CONTROL KNOB
6	X1693006	DEPTH CONTROL CRANK ARM
7	XPN08	HEX NUT 3/8-16
8	XPSS11	SET SCREW 1/4-20 X 1/4
9	X1693009	DEPTH CONTROL SHAFT
10	X1693010	DUST COVER
11	X1693011	TOP BRACE BAR
12	XPW14	FLAT WASHER 5/8
13	XPFB05	FLANGE BOLT 10-24 X 1/2
14	XPRP73M	ROLL PIN 4 X 30
15	X1693015	PLAIN TUBE A
16	X1693016	SLOTTED TUBE B
17	X1693017	SCALE
18	X1693018	ELEVATING SCREW COLLAR
18-1	X1693018-1	ELEVATING SCREW COLLAR
19	X1693019	ELEVATING SCREW
20	XPSS02	SET SCREW 5/16-18 X 3/8
21	X1693021	CUTTERHEAD PULLEY
23	X1693023	COLLAR
25	XP62042RS	BEARING 6204-2RS
26	X1693026	ARBOR
26-1	XPB18	HEX BOLT 3/8-16 X 1
26-2	XPW02	FLAT WASHER 3/8
27	X1693027	HEAD LOCKING HANDLE
28	XPW02	FLAT WASHER 3/8
29	X1693029	LOCKING HANDLE
30	X1693030	DUST COVER
31	X1693031	CHIP DEFLECTOR
32	XPB18	HEX BOLT 3/8-16 X 1
33	X1693033	FEED ROLLER SPROCKET
34	XPSS29	SET SCREW 10-24 X 1/4
35	X1693035	JOURNAL OUTFEED(B)
36	X1693036	BUSHING
37	X1693037	RUBBER IDLER ROLLER
37-1	XPW07	FLAT WASHER 5/16
38	X1693038	OUTFEED SWING ARM
39	X1693039	PIVOT PIN
40	X1693040	THREADED ROLLER SHAFT
41	X1739041	HEAD
42	X1693042	SWING ARM STOP PIN
43	X1693043	ROLLER PRESSURE SCREW
44	X1693044	COMPRESSION SPRING
45	X1693045	ROLLER PRESSURE GUIDE
46	X1693046	INFEED ROLLER DRIVE SHAFT

REF	PART #	DESCRIPTION
47	X1693047	INFEED SWING ARM
50	XPW06	FLAT WASHER 1/4
51	XPSB40	CAP SCREW 1/4-20 X 2
52	X1739052	CHAIN GUARD
53	X1693053	INFEED CHAIN
54	X1693054	OUTFEED CHAIN
56	X1693056	KNOB 1/4-20
57	X1693057	CHIP DEFLECTOR AXIS PIN
58	X1693058	BASE
59	XPSS09	SET SCREW 3/8-16 X 1/2
60	X1693060	BALL PLUNGER 3/8 X 20
61	X1693061	BIAS BUSHING
62	XPFH12	FLAT HD SCREW 1/4-20 X 1
63	XPS07	PHLP HD SCR 1/4-20 X 3/8
64	X1693064	C-CLAMP
65	X1693065	GUIDE RAILS
66	X1693066	CHAIN GUIDE
67	XPN02	HEX NUT 5/16-18
68	XPRP72M	ROLL PIN 3 X 15
69	X1693069	PLANER KNIVES
70	XPW02	FLAT WASHER 3/8
71	XPB21	HEX BOLT 3/8-16 X 3/4
72	XPS56M	PHLP HD SCR M4-.7 X 16
73	XPLW02M	LOCK WASHER 4MM
74	X1739074	END CASE
75	X1739075	DRIVE GEAR
76	X1739076	THRUST WASHER
77	X1739077	MAIN CASE
78	X1739078	STATOR HOUSING
79	X1739079	ARMATURE
80	X1739079	SHOULDER SCR M5-.8 X 90
81	XP6000	BEARING 6000 ZZ
80-1	XPLW01M	LOCK WASHER 5MM
82	X1739082	END CAP
82A	X1693082A	BRUSH SET AND ISOLATOR PLATE
83	XP608	BEARING 608ZZ
133	X1693133	UNPLUG POWER LABEL
134	X1693134	COVER WARNING LABEL
135	X1693135	READ MANUAL LABEL
201	X1693201	FEED ROLLER SPROCKET
202	X1739202	CONVEYOR MOTOR
203	X1739203	CONDUIT
204	X1739204	PLASTIC CORRUGATED TUBINGS
205	X1739205	CABLE CLAMPS
206	XPFB05	FLANGE BOLT 10-24 X 1/2
207	X1739207	SPECIAL FLAT HEAD SCREW
208	X1739208	BUSHING

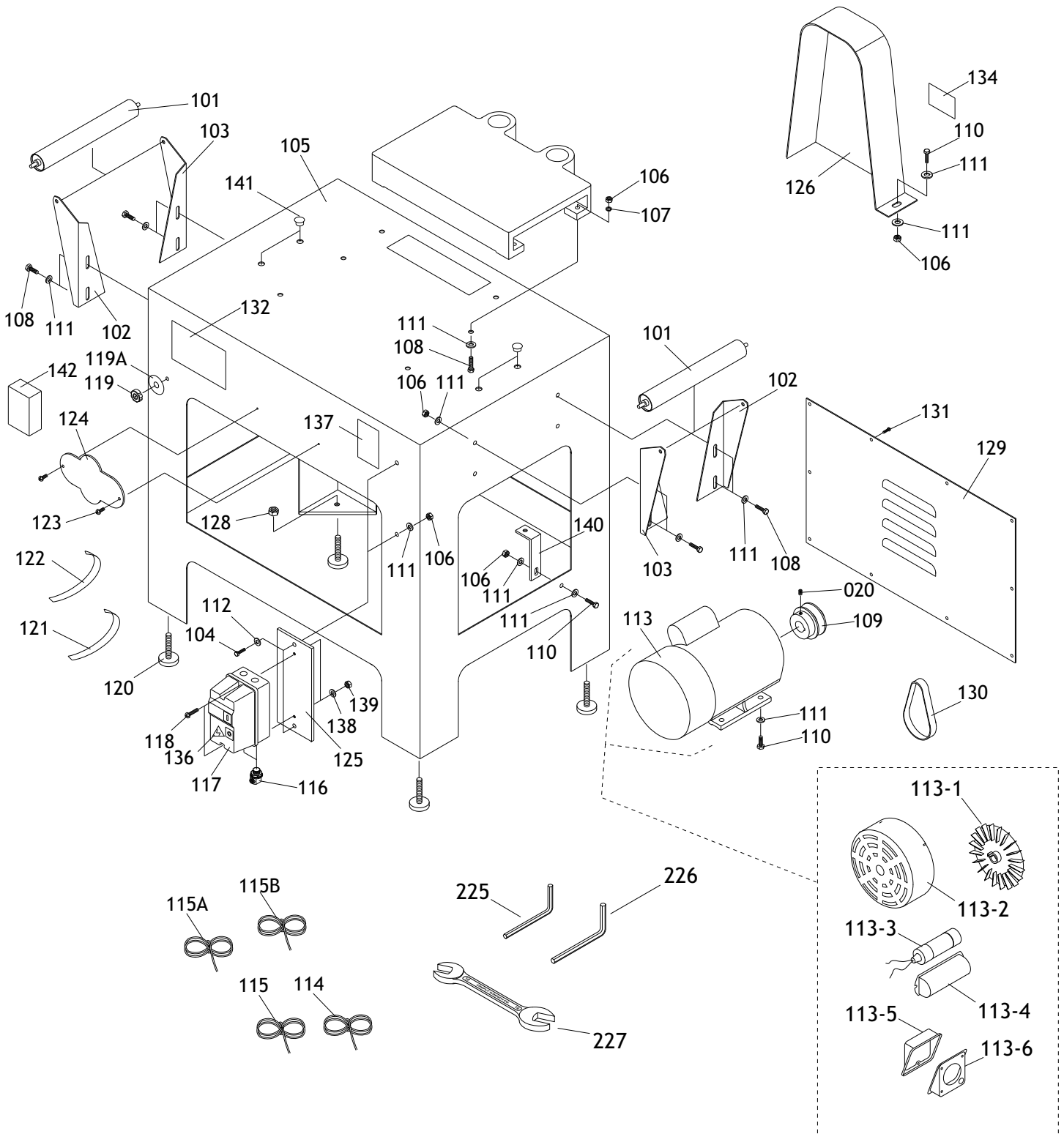

REF	PART #	DESCRIPTION
101	X1693101	EXTENSION ROLLER
102	X1693102	RIGHT BRACKET
103	X1693103	LEFT BRACKET
104	XPB32	HEX BOLT 5/16-18 X 5/8
105	X1739105	STAND
106	XPN02	HEX NUT 5/16-18
107	XPLW01	LOCK WASHER 5/16
108	XPB11	HEX BOLT 5/16-18 X 1-1/2
109	X1693109	MOTOR PULLEY
110	XPB07	HEX BOLT 5/16-18 X 3/4
111	XPW07	FLAT WASHER 5/16
113	X1693113	MOTOR 2HP 220V
113-1	XPK15M	KEY 5 X 5 X 35
113-2	X1693113-2	FAN
113-3	X1693113-3	FAN COVER
113-4	XPC400A	CAPACITOR 400MFD 125VAC
113-5	X1693113-5	CAPACITOR COVER
113-6	X1693113-6	MOTOR JUNCTION BOX COVER
113-7	X1739113-7	MOTOR JUNCTION BOX
114	X1693114	POWER CORD
115	X1693115	MOTOR CORD
115-1	X1739115-1	W1739 CONTROL CORD
115-2	X1739115-2	W1739 POWER CORD
116	X1693116	STRAIN RELIEF
117	X1693117	MAGNETIC SWITCH

REF	PART #	DESCRIPTION
118	XPS06	PHLP HD SCR 10-24 X 5/8
119	X1739119	VARIABLE SPEED CONTROL KNOB
119-1	X1739119-1	SPEED DIAL LABEL
120	X1693120	FOOT
121	X1693121	BOTTOM COLOR STRIPE
122	X1693122	UPPER COLOR STRIPE
123	XPS81	PHLP HD SCR #4-40 X 3/8
124	X1693124	SHOP FOX LOGO
125	X1693125	SWITCH PLATE
126	X1693126	PULLEY COVER
128	XPN08	HEX NUT 3/8-16
129	X1693129	VENTILATED REAR PANEL
130	X1693130	LINK BELT 1/2 X 48
131	XPFB05	FLANGE BOLT 10-24 X 1/2
132	X1739132	ID LABEL
136	X1693136	ELECTRICITY LABEL
137	X1693137	PROTECTION LABEL
138	XPW18	FLAT WASHER 3/16
139	XPN07	HEX NUT 10-24
140	X1693140	BRACKET
141	X1693141	DUST PLUG
142	X1739142	PC BOARD CONSOLE UNIT 220V
225	XPAW03M	HEX WRENCH 3MM
226	XPAW04M	HEX WRENCH 4MM
227	X1693227	OPEN-END WRENCH 12/14MM