

Grizzly *Industrial, Inc.*®

MODEL H7583 TENONING JIG OWNER'S MANUAL

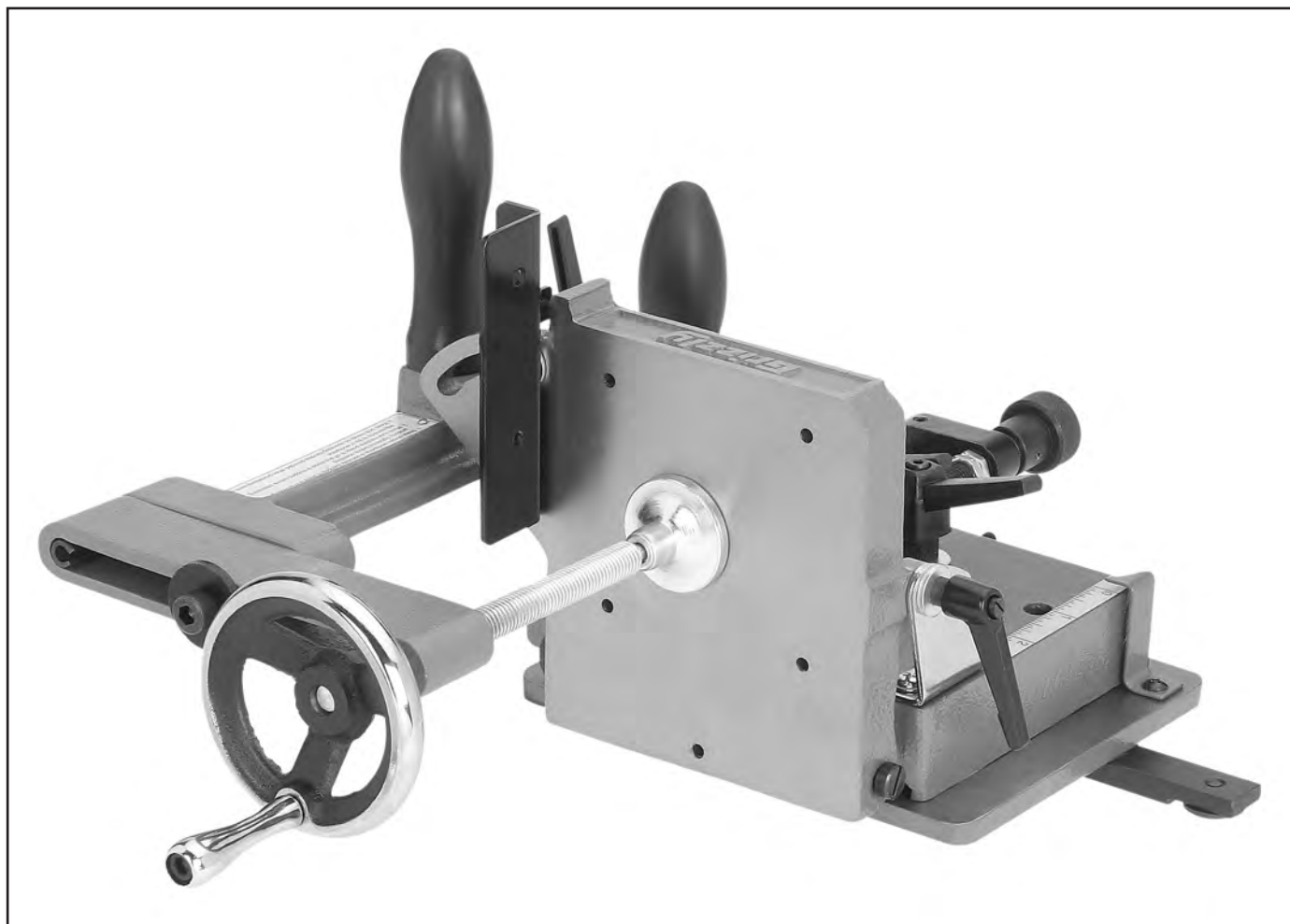

COPYRIGHT © MAY, 2005 BY GRIZZLY INDUSTRIAL, INC., REVISED JANUARY, 2009 (TS)

**WARNING: NO PORTION OF THIS MANUAL MAY BE REPRODUCED IN ANY SHAPE
OR FORM WITHOUT THE WRITTEN APPROVAL OF GRIZZLY INDUSTRIAL, INC.**

#EW7181 PRINTED IN CHINA

 **WARNING!**

This manual provides critical safety instructions on the proper setup, operation, maintenance and service of this machine/equipment.

Failure to read, understand and follow the instructions given in this manual may result in serious personal injury, including amputation, electrocution or death.

The owner of this machine/equipment is solely responsible for its safe use. This responsibility includes but is not limited to proper installation in a safe environment, personnel training and usage authorization, proper inspection and maintenance, manual availability and comprehension, application of safety devices, blade/cutter integrity, and the usage of personal protective equipment.

The manufacturer will not be held liable for injury or property damage from negligence, improper training, machine modifications or misuse.

 **WARNING!**

Some dust created by power sanding, sawing, grinding, drilling, and other construction activities contains chemicals known to the State of California to cause cancer, birth defects or other reproductive harm. Some examples of these chemicals are:

- **Lead from lead-based paints.**
- **Crystalline silica from bricks, cement and other masonry products.**
- **Arsenic and chromium from chemically-treated lumber.**

Your risk from these exposures varies, depending on how often you do this type of work. To reduce your exposure to these chemicals: Work in a well ventilated area, and work with approved safety equipment, such as those dust masks that are specially designed to filter out microscopic particles.

Table of Contents

- INTRODUCTION..... 2**
 - Manual Accuracy..... 2
 - Contact Info..... 2
 - Functional Overview..... 2
 - Table Saw Requirements..... 2
 - Identification 3

- SECTION 1: SAFETY 4**
 - Safety Instructions for Machinery..... 4
 - Additional Safety Instructions for the Tenoning Jig..... 6

- SECTION 2: SETUP 7**
 - Items Needed for Setup 7
 - Unpacking 7
 - Inventory..... 8
 - Clean Up 8
 - Table Saw Preparation..... 9
 - Tenoning Jig Preparation 9
 - Assembly..... 9
 - Guide Bar Mounting Configuration..... 10
 - Guide Bar Adjustment..... 12
 - Side Support Adjustment 12
 - Back Support Adjustment..... 13
 - Blade Clearance Adjustment..... 14

- SECTION 3: OPERATIONS 16**
 - Operation Safety 16
 - Basic Tenon Cutting..... 16

- SECTION 4: ACCESSORIES 22**

- SECTION 5: MAINTENANCE..... 24**
 - Schedule 24
 - Cleaning 24
 - Lubrication & Storage..... 24

- SECTION 6: PARTS 25**
 - Parts Breakdown..... 25
 - Parts List 26

- WARRANTY AND RETURNS 29**

INTRODUCTION

Manual Accuracy

We are proud to offer this manual with your new machine! We've made every effort to be exact with the instructions, specifications, drawings, and photographs of the machine we used when writing this manual. However, sometimes errors do happen and we apologize for them.

Also, owing to our policy of continuous improvement, **your machine may not exactly match the manual.** If you find this to be the case, and the difference between the manual and machine leaves you in doubt, immediately call our technical support for updates or clarification.

For your convenience, we always keep current Grizzly manuals and most updates available on our website at www.grizzly.com. Any updates to your machine will be reflected in these documents as soon as they are complete. Visit our site often to check for the latest updates!

Contact Info

We stand behind our machines. If you have any service questions, parts requests or general questions about the machine, please call or write us at the location listed below.

Grizzly Industrial, Inc.
1203 Lycoming Mall Circle
Muncy, PA 17756
Phone: (570) 546-9663
Fax: (800) 438-5901
E-Mail: techsupport@grizzly.com

If you have any comments regarding this manual, please write to us at the address below:

Grizzly Industrial, Inc.
c/o Technical Documentation Manager
P.O. Box 2069
Bellingham, WA 98227-2069
Email: manuals@grizzly.com

Functional Overview

The tenoning jig is designed to work with your table saw to make a tenon, such as shown in **Figure 1**, which will be part of a mortise and tenon joint.

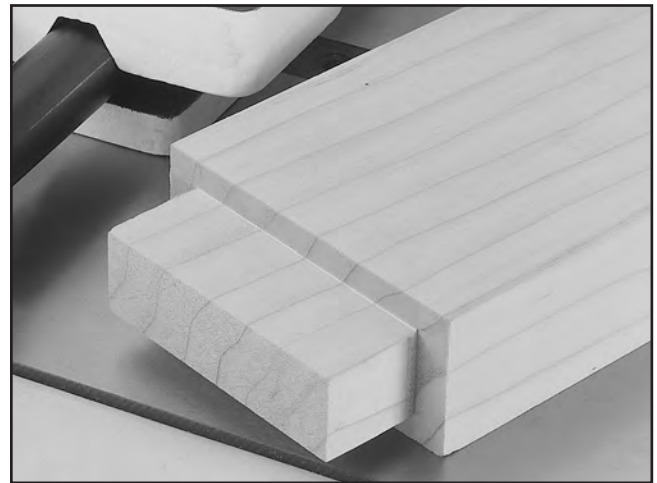

Figure 1. Example of a completed basic tenon.

With the tenoning jig mounted into the miter slot of the table saw, the workpiece is clamped upright to the jig in various configurations so that the tenon cheek cuts can be made. Then, the jig is removed and the workpiece is laid flat on the table saw to make the shoulder cuts.

Table Saw Requirements

The H7583 Tenoning Jig is designed to work with most table saws. Use the table saw requirements listed below to verify that your table saw will work with the tenoning jig.

Table Saw Miter Slot	Standard $\frac{3}{4}$ " w/T-Slot
Distance from Miter Slot Center to Blade:	
Minimum	$3\frac{3}{4}$ "
Maximum	$6\frac{3}{4}$ "



Identification

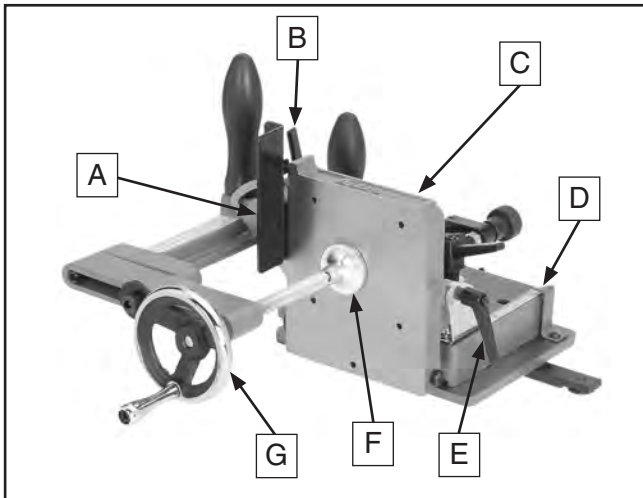

Figure 2. H7583 identification, right side.

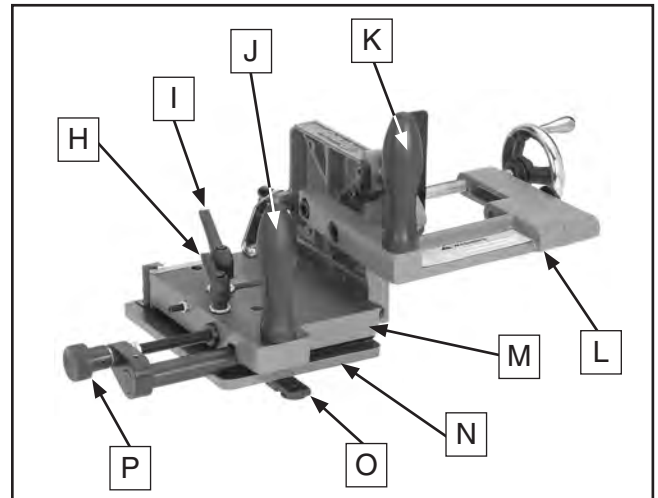

Figure 3. H7583 identification, left side.

- A. Back Support
- B. Back Support Lock Lever
- C. Side Support
- D. Depth of Cut Scale & Pointer
- E. Side Support Tilt Lock Lever
- F. Clamp Shoe
- G. Clamp Handwheel
- H. Micro-Adjust Lock Lever

- I. Slide Plate Lock Lever
- J. Slide Plate Handle
- K. Clamp Handle
- L. Clamp Brace
- M. Slide Plate
- N. Base Plate
- O. Guide Bar
- P. Micro-Adjust Knob

NOTICE

If you have never used this type of machine or equipment before, WE STRONGLY RECOMMEND that you read books, trade magazines, or get formal training before beginning any projects. Regardless of the content in this section, Grizzly Industrial will not be held liable for accidents caused by lack of training.



SECTION 1: SAFETY

WARNING

For Your Own Safety, Read Instruction Manual Before Operating this Machine

The purpose of safety symbols is to attract your attention to possible hazardous conditions. This manual uses a series of symbols and signal words intended to convey the level of importance of the safety messages. The progression of symbols is described below. Remember that safety messages by themselves do not eliminate danger and are not a substitute for proper accident prevention measures.



Indicates an imminently hazardous situation which, if not avoided, **WILL** result in death or serious injury.



Indicates a potentially hazardous situation which, if not avoided, **COULD** result in death or serious injury.



Indicates a potentially hazardous situation which, if not avoided, **MAY** result in minor or moderate injury. It may also be used to alert against unsafe practices.

NOTICE

This symbol is used to alert the user to useful information about proper operation of the machine.

WARNING

Safety Instructions for Machinery

- 1. READ THE ENTIRE MANUAL BEFORE STARTING MACHINERY.** Machinery presents serious injury hazards to untrained users.
- 2. ALWAYS USE ANSI APPROVED SAFETY GLASSES WHEN OPERATING MACHINERY.** Everyday eyeglasses only have impact resistant lenses—they are NOT safety glasses.
- 3. ALWAYS WEAR A NIOSH APPROVED RESPIRATOR WHEN OPERATING MACHINERY THAT PRODUCES DUST.** Most types of dust (wood, metal, etc.) can cause severe respiratory illnesses.
- 4. ALWAYS USE HEARING PROTECTION WHEN OPERATING MACHINERY.** Machinery noise can cause permanent hearing loss.
- 5. WEAR PROPER APPAREL. DO NOT** wear loose clothing, gloves, neckties, rings, or jewelry that can catch in moving parts. Wear protective hair covering to contain long hair and wear non-slip footwear.
- 6. NEVER OPERATE MACHINERY WHEN TIRED OR UNDER THE INFLUENCE OF DRUGS OR ALCOHOL.** Be mentally alert at all times when running machinery.



WARNING

Safety Instructions for Machinery

7. **ONLY ALLOW TRAINED AND PROPERLY SUPERVISED PERSONNEL TO OPERATE MACHINERY.** Make sure operation instructions are safe and clearly understood.
8. **KEEP CHILDREN AND VISITORS AWAY.** Keep all children and visitors a safe distance from the work area.
9. **MAKE WORKSHOP CHILDPROOF.** Use padlocks, master switches, and remove start switch keys.
10. **NEVER LEAVE WHEN MACHINE IS RUNNING.** Turn power **OFF** and allow all moving parts to come to a complete stop before leaving machine unattended.
11. **DO NOT USE IN DANGEROUS ENVIRONMENTS.** DO NOT use machinery in damp, wet locations, or where any flammable or noxious fumes may exist.
12. **KEEP WORK AREA CLEAN AND WELL LIGHTED.** Clutter and dark shadows may cause accidents.
13. **USE A GROUNDED EXTENSION CORD RATED FOR THE MACHINE AMPERAGE.** Grounded cords minimize shock hazards. Undersized cords create excessive heat. Always replace damaged extension cords.
14. **ALWAYS DISCONNECT FROM POWER SOURCE BEFORE SERVICING MACHINERY.** Make sure switch is in OFF position before reconnecting.
15. **MAINTAIN MACHINERY WITH CARE.** Keep blades sharp and clean for best and safest performance. Follow instructions for lubricating and changing accessories.
16. **MAKE SURE GUARDS ARE IN PLACE AND WORK CORRECTLY BEFORE USING MACHINERY.**
17. **REMOVE ADJUSTING KEYS AND WRENCHES.** Make a habit of checking for keys and adjusting wrenches before turning machinery **ON**.
18. **CHECK FOR DAMAGED PARTS BEFORE USING MACHINERY.** Check for binding or misaligned parts, broken parts, loose bolts, and any other conditions that may impair machine operation. Repair or replace damaged parts before operation.
19. **USE RECOMMENDED ACCESSORIES.** Refer to the instruction manual for recommended accessories. Improper accessories increase risk of injury.
20. **DO NOT FORCE MACHINERY.** Work at the speed for which the machine or accessory was designed.
21. **SECURE WORKPIECE.** Use clamps or a vise to hold the workpiece when practical. A secured workpiece protects your hands and frees both hands to operate the machine.
22. **DO NOT OVERREACH.** Maintain stability and balance at all times.
23. **MANY MACHINES CAN EJECT WORKPIECES TOWARD OPERATOR.** Know and avoid conditions that cause the workpiece to "kickback."
24. **ALWAYS LOCK MOBILE BASES (IF USED) BEFORE OPERATING MACHINERY.**
25. **CERTAIN DUST MAY BE HAZARDOUS** to the respiratory systems of people and animals, especially fine dust. Be aware of the type of dust you are exposed to and always wear a respirator designed to filter that type of dust.



WARNING

Additional Safety Instructions for the Tenoning Jig

- 1. OWNER'S MANUAL.** READ and UNDERSTAND this manual and the one for your table saw before using this jig!
- 2. KICKBACK.** Be familiar with kickback. Kickback happens when the blade grabs the workpiece and launches it toward the operator at a high rate of speed. *Until you have a clear understanding of kickback and how it occurs, DO NOT operate the table saw!*
- 3. REACHING OVER SAW BLADE.** Never reach behind or over the saw blade with either hand while the saw is running. *If kickback occurs while reaching over the blade, hands or arms could be pulled into the spinning blade.*
- 4. OPERATOR POSITION.** Never stand or have any part of your body directly in-line with the cutting path of the saw blade. Avoid awkward operations and hand positions where a sudden slip could cause your hand to move into the spinning saw blade.
- 5. SECURING WORKPIECE.** ALWAYS securely clamp the workpiece in the tenoning jig, and make sure all fasteners and lock levers are tight before you start the saw. ALWAYS make sure that the jig will not make contact with the saw blade during operation.
- 6. JIG CONTROL.** ALWAYS firmly hold both tenoning jig handles when cutting. NEVER hold the jig with one hand.
- 7. ADJUSTING JIG.** Disconnect the saw from power BEFORE installing or adjusting the jig, saw, or workpiece.
- 8. TENON MATERIAL SELECTION.** Select clean tenon locations that are low in moisture content, and are free of knots, staples, nails, and imbedded debris.
- 9. REMOVE TOOLS.** Remove tools and other items from the jig and table saw before turning the saw **ON** to avoid the risk of these items being thrown at the operator or bystander with a high rate of speed.
- 10. AVOIDING ENTANGLEMENT.** DO NOT wear loose clothing, gloves, or jewelry when the saw is **ON**. Tie back long hair and roll up sleeves.
- 11. ACCESSORIES.** Make sure other accessories used on the table saw do not interfere with the operation of the tenoning jig.
- 12. BLADE GUARD.** Always re-install the blade guard and any other safety features for the table saw when the tenoning jig is removed.
- 13. EXPERIENCING DIFFICULTIES.** If at any time you are experiencing difficulties performing the intended operation, stop using the machine and contact Tech Support at (570) 546-9663.

WARNING

Like all machinery there is potential danger when using this jig with a table saw. Accidents are frequently caused by lack of familiarity or failure to pay attention. Use this tool with respect and caution to decrease the risk of operator injury. If normal safety precautions are overlooked or ignored, serious personal injury may occur.



SECTION 2: SETUP

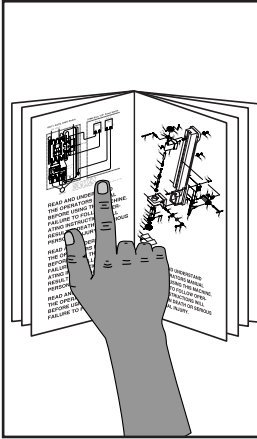

!WARNING

Using the jig with the table saw presents serious injury hazards to untrained users. Read through this entire manual and the one for your table saw to become familiar with the controls and operations before starting the table saw!

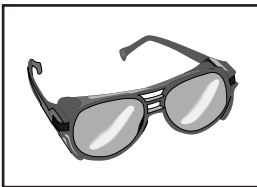

!WARNING

Wear safety glasses during the entire setup process!

Needed for Setup

The following are needed to complete the setup process, but are not included with your machine:

Description	Qty
• Square 90°	1
• Shop Rags & Solvent	As Needed
• Wrench 8mm	1
• Wrench 10mm	1
• Wrench 14mm	1
• Machinist's Square	1

Unpacking

Your machine was carefully packaged for safe transportation. Remove the packaging materials from around your machine and inspect it. If you discover the machine is damaged, *please immediately call Customer Service at (570) 546-9663 for advice.*

Save the containers and all packing materials for possible inspection by the carrier or its agent. *Otherwise, filing a freight claim can be difficult.*

When you are completely satisfied with the condition of your shipment, inventory the contents.



Inventory

The following is a description of the main components shipped with your machine. Lay the components out to inventory them.

Note: *If you can't find an item on this list, check the mounting location on the machine or examine the packaging materials carefully. Occasionally we pre-install certain components for shipping purposes.*

Inventory: (Figure 4)	Qty
A. Tenoning Jig Assembly	1
B. Clamp Handwheel	1
C. Clamp Shoe & Bracket	1
D. Clamp Brace	1
E. Handles	2

Hardware & Tools (not shown):	Qty
• Lock Washers 10mm	2
• Fender Washer 8mm	1
• Cap Screw M8-1.25 x 50	1
• Cap Screw M10-1.5 x 25	1
• Cap Screw M10-1.5 x 20	1
• Hex Wrenches 2.5, 3, 4, 6, 8mm	1 Each

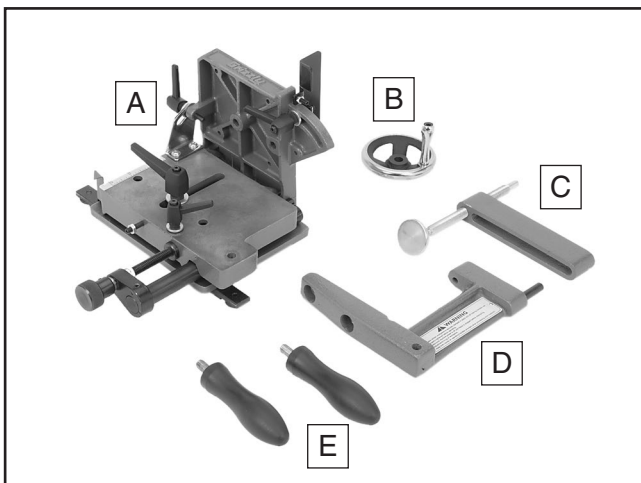



Figure 4. Model H7583 inventory.

If any nonproprietary parts are missing (e.g. a nut or a washer), we will gladly replace them; or for the sake of expediency, replacements can be obtained at your local hardware store.

Clean Up

The unpainted surfaces are coated with a waxy oil to prevent corrosion during shipment. Remove this protective coating with a solvent cleaner or degreaser, such as shown in **Figure 5**. For thorough cleaning, some parts must be removed. **For optimum performance, clean all moving parts or sliding contact surfaces.** Avoid harsh solvents like acetone or brake parts cleaner that may damage painted surfaces. Always follow the manufacturer's instructions when using any type of cleaning product.

	<p>! WARNING</p> <p>Gasoline and petroleum products have low flash points and can explode or cause fire if used to clean machinery. DO NOT use these products to clean the machinery.</p>
--	---

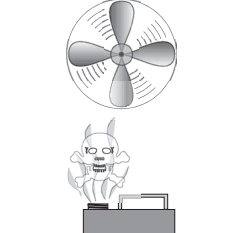
	<p>! CAUTION</p> <p>Many cleaning solvents are toxic if inhaled. Minimize your risk by only using these products in a well ventilated area.</p>
--	--

G2544—Solvent Cleaner & Degreaser

H9692—Orange Power Degreaser

Great products for removing shipping grease.

<p>Call 1-800-523-4777 To Order</p>	
--	---

Figure 5. Cleaner/degreasers available from Grizzly.



Table Saw Preparation

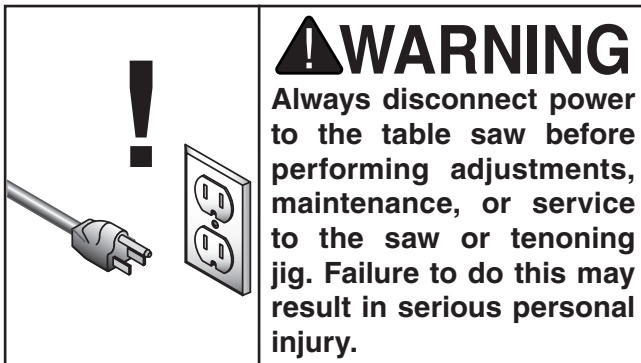

The Model H7583 Tenoning Jig is designed to work with a table saw that has a $\frac{3}{8}$ " x $\frac{3}{4}$ " miter T-slot on the left side of the blade. To help ensure safe and accurate tenons, follow these rules to properly prepare your table saw before using it with the jig.

- **Table Saw Operation:** Make sure that you read and understand your table saw owner's manual, and take all instructed safety precautions.
- **Riving Knife:** You must use a riving knife that is properly installed behind the blade to ensure the kerf does not close on the blade and cause kickback.
- **Saw Blades:** Make sure that your saw blades are not damaged and that the teeth are sharp.
- **Saw Adjustments:** When using the tenoning jig, the accuracy of the cuts depend upon the accuracy of the saw blade. Make sure that your saw blade is perpendicular to the table and parallel with the miter slots.
- **Miter Slot and Table:** Make sure the miter slots and table are free from burrs or debris that may interfere with the smooth operation of the jig.
- **Lighting:** Make sure the top of your table has adequate lighting so that the tenoning jig and workpiece are properly illuminated without shadows.

Tenoning Jig Preparation

To properly assemble and adjust your tenoning jig, you must do the following procedures before using it to make tenons:

- Assembly.
- Guide Bar Mounting Configuration (**Page 10**).
- Guide Bar Adjustment (**Page 12**).
- Side Support Adjustment (**Page 12**).
- Back Support Adjustment (**Page 13**).
- Blade Clearance Adjustment (**Page 14**).

Assembly

To assemble your tenoning jig:

1. Attach the clamp brace to the back of the side support with the M10-1.5 cap screws and lock washers, as shown in **Figure 6**.

Note: These cap screws are different lengths and must go into the correct holes (see **Figure 6**).

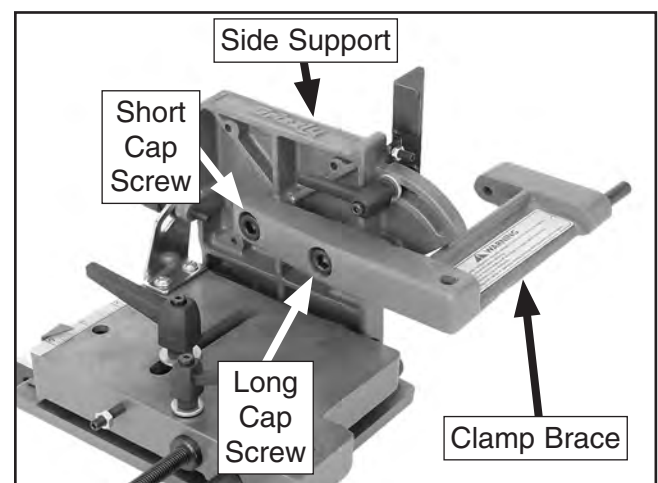

Figure 6. Clamp brace installed.



2. Install the handles into the threaded holes on the clamp brace and the slide plate, as shown in **Figure 7**.

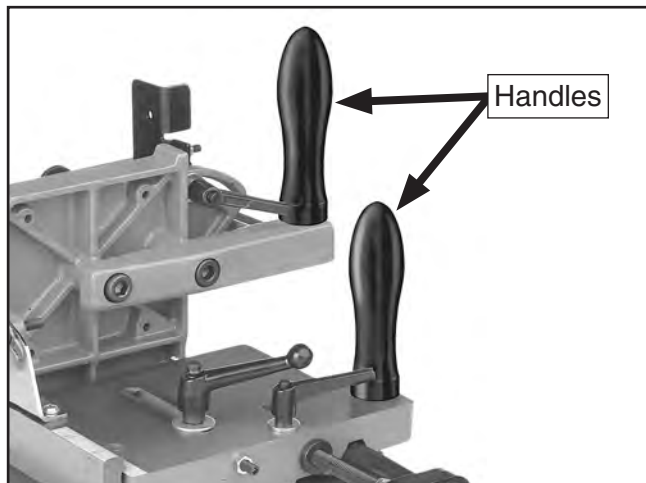

Figure 7. Handles installed.

3. Slide the clamp bracket over the rod of the clamp brace, as shown in **Figure 8**, then secure it with the M8-1.25 cap screw and fender washer.

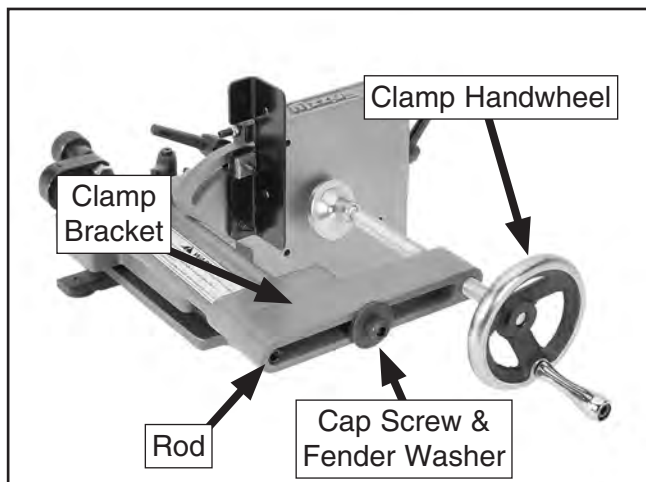

Figure 8. Clamp shoe, bracket, and handwheel installed.

4. Align the set screw in the hub of the handwheel with the flat of the clamp shaft, then slide the handwheel onto the shaft and tighten the set screw (see **Figure 8**).

Guide Bar Mounting Configuration

The guide bar of the tenoning jig can be mounted to the base plate in two positions, depending on the distance between the table's left-hand miter slot from the blade. The jig ships with the guide bar mounted in the inward position. If the jig needs to be closer to the blade, you need to mount the guide bar in outward position.

To re-mount the guide bar in the outward position:

1. Remove the slide plate lock lever and flat washer, then un-thread the long set screw the lock lever was attached to (see **Figure 9**).

Note: *The set screw will fall down between the slide and base plates and will be accessible in the following steps.*

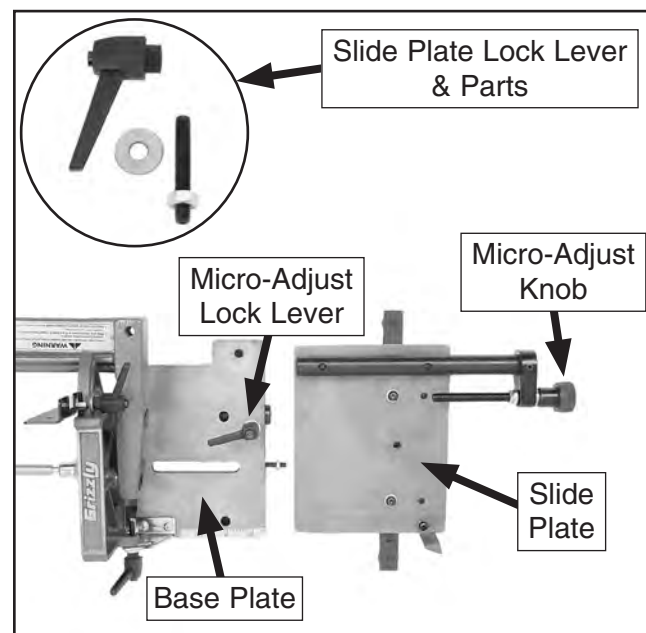

Figure 9. Separating the slide and base plates.

2. Loosen the micro-adjust lock lever, then rotate the micro-adjust knob counterclockwise to force the slide plate to move and separate from the micro-adjust screw, as shown in **Figure 9**.



- Loosen the set screw on the micro-adjust collar, then remove the micro-adjust assembly from the rod, as shown in **Figure 10**.

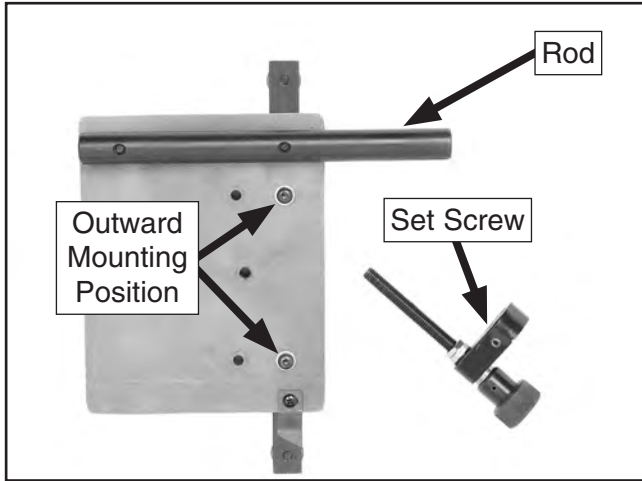

Figure 10. Guide bar mounted in the outward position.

- Remove the cap screws and washers securing the guide bar to the base plate, then re-install the bar in the outward mounting position, as shown in **Figure 10**.
- Thread the long set screw removed in **Step 1** back into the middle, inward hole on the base plate, then tighten down the jam nut to secure it.
- Loosen the pointer screw and swing the pointer out of the way for the next step.
- Place the slide plate over the upright set screw, as shown in **Figure 11**.

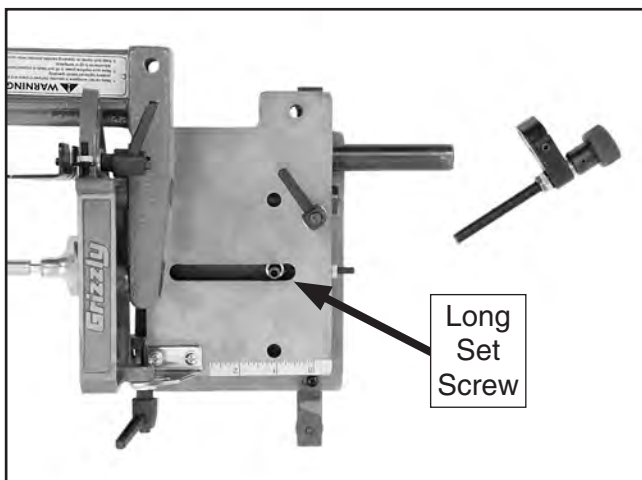

Figure 11. Slide plate positioned over the base plate.

- Slide the micro-adjust collar onto the rod, align the micro-adjust screw with the threaded guide shaft of the slide plate, then rotate the knob clockwise until the collar is even with the rod, as shown in **Figure 12**.

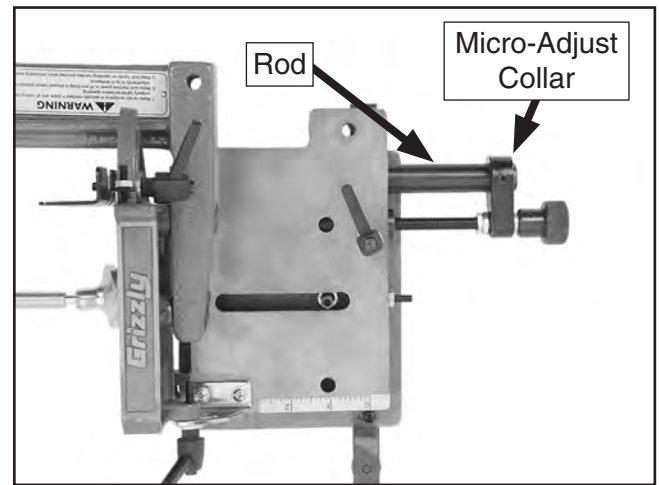

Figure 12. Micro-adjust assembly properly positioned.

- With one hand pressing the slide plate flat against the base plate to properly align the micro-adjust assembly, fully tighten the set screw on the micro-adjust collar to secure it to the rod.
- Re-position and secure the pointer, then re-install the slide plate lock lever and flat washer.

To mount the guide bar in the inward position:

- Perform the outward mounting procedure but install the guide bar using the left row of mounting holes on the base plate.

Guide Bar Adjustment

In this procedure you will adjust the guide bar so that it slides back-and-forth in the table saw miter slot without side-to-side play or tilt that would make the operation unsafe or produce poor cutting results.

To adjust the guide bar:

1. DISCONNECT TABLE SAW FROM POWER!

2. Insert the tenoning jig guide bar into the table saw miter slot, then slide it back-and-forth.

—If the guide bar fits snugly, but slides freely in the miter slot, no adjustment is necessary to the guide bar. Continue with the **Side Support Adjustment** procedure on this page.

—If side-to-side play or tilt exists, continue with **Step 3**.

3. Remove the jig from the table saw and turn it upside down, as shown in **Figure 13**.

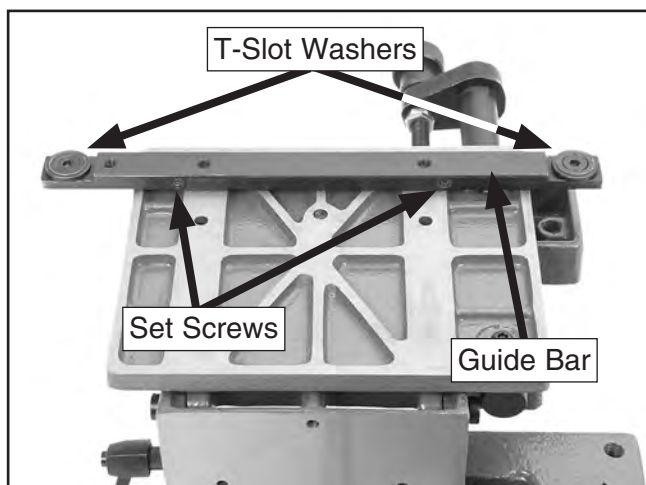

Figure 13. Guide bar.

4. Evenly adjust the set screws shown in **Figure 13** the same amount so that they protrude from the guide bar enough to take up the side-to-side play experienced in **Step 2**.
5. Make sure the cap screws securing the T-slot washers are tight.
6. Repeat **Steps 2–5** until you are satisfied with the movement of the guide bar in the saw miter slot.

Side Support Adjustment

In this procedure you will adjust the side support so it is perpendicular to the table of the saw. Then you will set the 90° positive stop so the support can be quickly returned to the perpendicular position after an angle cut.

To adjust the side support:

1. DISCONNECT TABLE SAW FROM POWER!
2. Make sure the saw blade is perpendicular to the table miter slot (refer to your Owner's Manual for the table saw for instructions).
3. Completely lower the saw blade so that it will not interfere with the measurements.
4. Clean away any debris from the table or jig that could affect the measurements, then insert the jig all the way into the miter slot.

⚠WARNING

DO NOT remove the T-slot washer from the ends of the tenoning jig guide bar. Removal of the washer will allow the tenoning jig to come loose from the table during a kickback situation, possibly causing a serious personal injury or property damage.



5. Thread the positive stop set screw far enough away from the side support so that it will not interfere with the next step (see **Figure 14**).

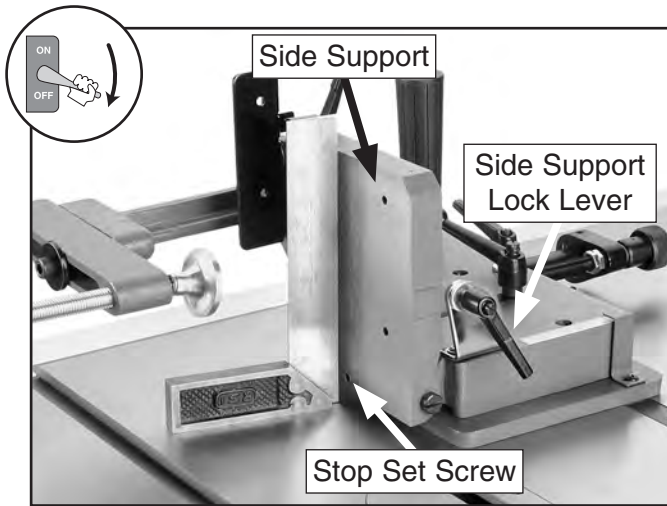

Figure 14. Adjusting the side support perpendicular to the saw table.

6. Position the machinist's square flat on the table and up against the jig side support.
7. Loosen the support lock lever, position the side support flat against the machinist's square, then, without moving the support, re-tighten the lock lever.
8. Remove the square and re-tighten the stop set screw until it just meets resistance. The 90° positive stop is now set for quick perpendicular positioning of the side support.

Back Support Adjustment

In this procedure you will adjust the back support perpendicular to the saw table, then set the 90° positive stop so the back support can be returned to the perpendicular position after an angle cut.

To adjust the back support:

1. DISCONNECT TABLE SAW FROM POWER!
2. Completely lower the saw blade so that it will not interfere with the measurements.
3. Clean away any debris from the table or jig that could affect the measurements, then insert the jig all the way into the miter slot.
4. Loosen the jam nut on the positive set screw, then back off the set screw to allow adjustment to the back support (see **Figure 15**).

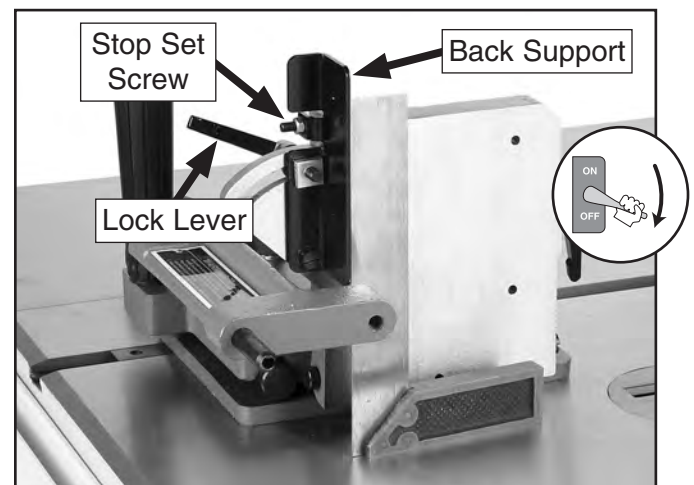

Figure 15. Adjusting the back support perpendicular to the saw table.

5. Position the machinist's square flat on the table and up against the back support of the jig, as shown in **Figure 15**.
6. Loosen the support lock lever, position the back support flat against the machinist's square, then, without moving the support, re-tighten the lock lever.
7. Remove the square and re-tighten the stop set screw until it just meets resistance, then re-tighten the jam nut to secure the setting. The 90° positive stop is now set for quick perpendicular positioning of the back support.



Blade Clearance Adjustment

In this procedure you will adjust the side support to be parallel with the saw blade and 1/2" away from it, then set the safety stop set screw (see **Figure 16**) so that the side support cannot come into contact with the blade when adjusting for different cuts.

⚠️ WARNING

Make sure the side support safety stop is adjusted correctly so that the support cannot come in contact with the blade when the jig is properly mounted in the left-hand table miter slot before using the jig. The jig side support must stay at least 1/2" away from the blade at all times during operation. If the side support and blade make contact, serious personal injury could result. At best, the blade and jig will be damaged.

To adjust the blade clearance:

1. DISCONNECT TABLE SAW FROM POWER!
2. Make sure the saw blade is perpendicular to the table and parallel with the miter slot.
3. Make sure the jig side support is perpendicular to the table (refer to **Side Support Adjustment** on **Page 12** for detailed instructions).

4. Loosen the jam nut on the safety stop set screw, then back the set screw out so that it will not interfere with adjustments (see **Figure 16**).

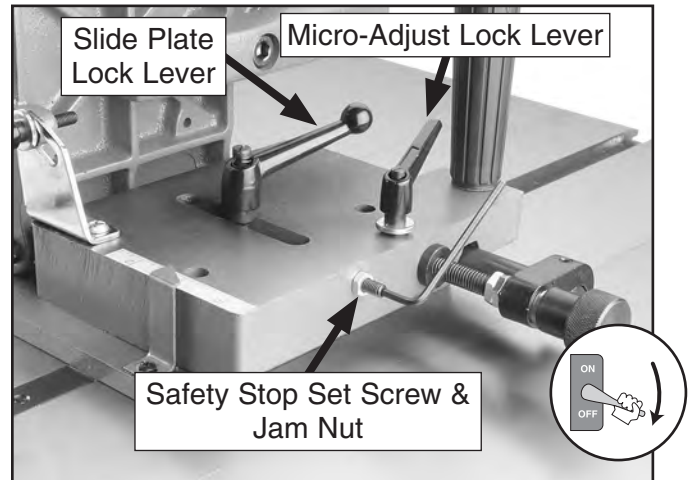

Figure 16. Side support safety stop.

5. Fully raise the saw blade.
6. Loosen the slide plate and micro-adjust lock levers, then use the clamp handwheel to move the clamp screw and shoe out of the way for the next step (see **Figure 17**).

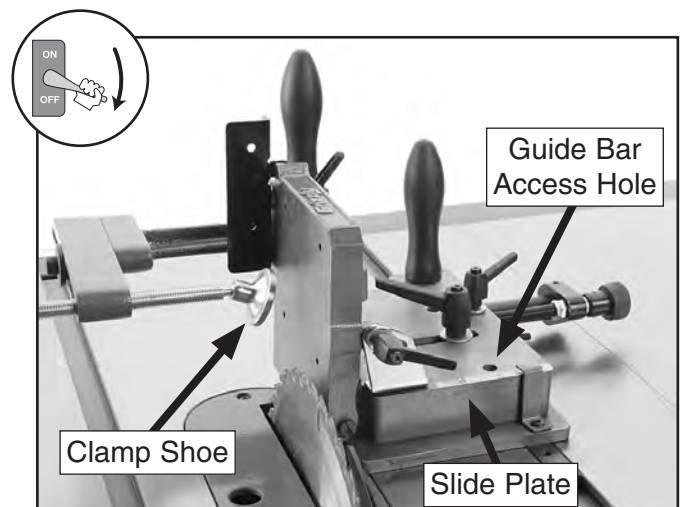

Figure 17. Checking for side support parallelism with the saw blade.



7. Use the micro-adjust knob to move the side support against the saw blade.

Note: *If the jig side support will not reach the blade, you may need to re-mount the guide bar in the inward or left mounting position (refer to **Guide Bar Mounting Configuration** on **Page 10** for detailed instructions). If it still does not reach the blade after changing the guide bar mounting position, the difference can be made up when attaching the side support backing board (refer to **Step 5 of Basic Tenon Cutting** beginning on **Page 16** for detailed instructions).*

—If the jig side support is parallel with the saw blade, no adjustments are necessary.

—If the side support and blade are not parallel, note the difference and continue with **Step 8**.

Note: *If the side support does not quite reach the blade, use a precise ruler to compare the distance between the side support and the front and back of the blade.*

8. Use the micro-adjust knob to align the guide bar access hole of the slide plate over the cap screw of the guide bar (see **Figure 17**), then loosen the cap screw.

9. Shift the end of the jig assembly with the access hole one way or the other so that the side support will be parallel with the blade, then tighten the guide bar cap screw.

10. Repeat **Steps 7–9** until the jig side support is parallel to the saw blade.

11. When the side support is parallel with the blade, use the micro-adjust knob to move the side support at least $\frac{1}{2}$ " away from the saw blade.

12. Tighten the safety set screw toward the slide plate lock set screw until it just meets resistance, then tighten the jam nut to secure the setting. The safety set screw is now correctly set to prevent the side support from contacting the saw blade.



SECTION 3: OPERATIONS

Operation Safety

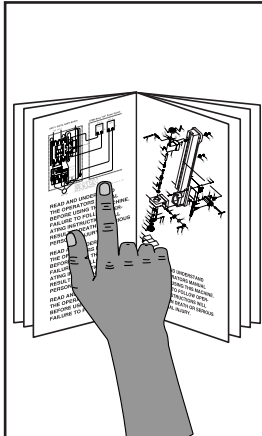

!WARNING
Using the jig with the table saw presents serious injury hazards to untrained users. Read through this entire manual and the one for your table saw to become familiar with the controls and operations before starting the table saw!

!WARNING
Damage to your eyes and lungs could result from using the table saw without proper protective gear. Always wear safety glasses and a respirator when operating this machine.

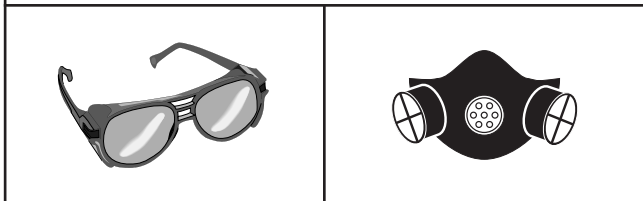

!CAUTION
No list of safety guidelines can be complete. Every shop environment is different. Always consider safety first, as it applies to your individual working conditions. Use this and other machinery and tools with caution and respect. Failure to do so could result in serious personal injury, damage to equipment, or poor work results.

Basic Tenon Cutting

Your tenoning jig is designed to make tenon cheek cuts only. Generally, cheek cuts are made before the shoulder cuts, which are then made without using the jig (see **Figure 18**).

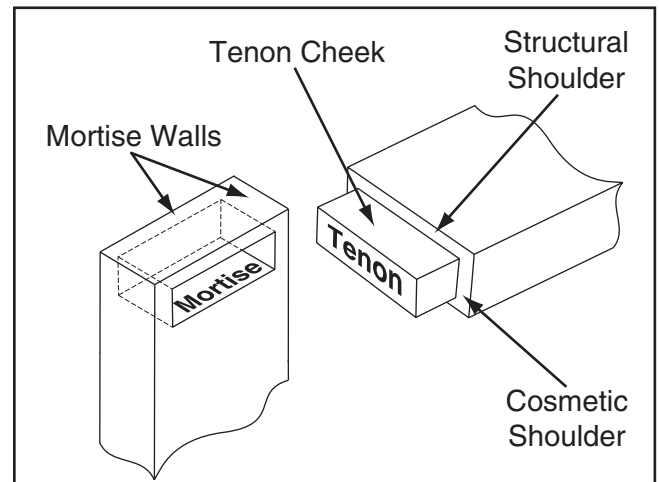

Figure 18. Illustration of typical basic mortise and tenon.

The following three procedures will guide you through the process of cutting a basic tenon.

Preparing Jig & Workpiece

1. DISCONNECT TABLE SAW FROM POWER!
2. Select stock for your mortise and tenon joint, then draw the cutting lines, as shown in **Figures 18–19**.





Figure 19. Mortise and tenon cutting lines.

- Select joint locations that are free from knots and grain twists that could break when stressed.
- Tenons need structural and cosmetic shoulders to strengthen the joint and hide gaps that may occur as the wood shrinks with age.
- When the thickness of the mortise and tenon stock are the same, make the tenon the same thickness as the mortise walls.
- When jointing stock where the mortise piece is thicker than the tenon piece, make the tenon as thick as possible without making the mortise walls too thin.
- Make sure there is a slight space between the bottom of the tenon and the bottom of the mortise for glue squeeze out. If you use a mortise chisel and bit to make the mortise, generally the indents from the bit tip at the bottom of the mortise are sufficient.

3. Plane a piece of wood approximately $\frac{3}{8}$ " thick to match the base plate of the jig, then clamp it to the front of the table and even with the right side of the jig base plate, as shown in **Figure 20**.

Note: *This additional base piece provides a level surface with the jig base plate to set the workpiece on when clamping it to the jig in later steps. This configuration also reduces the risk of the workpiece bottom binding with the table as it slides through the blade during a cut.*

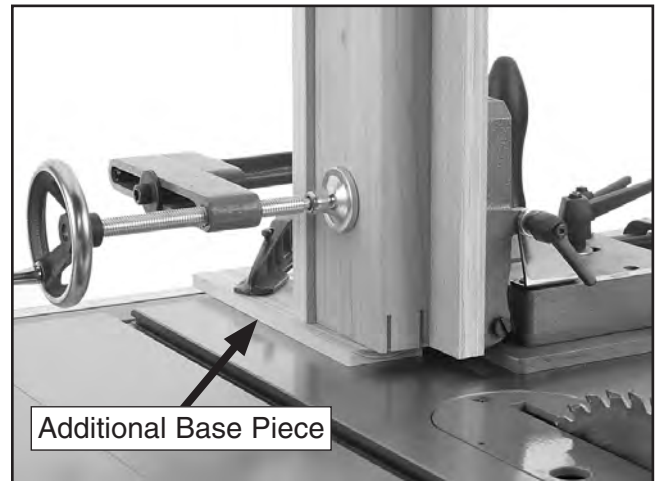

Figure 20. Example of additional base piece clamped to the saw table.

⚠️ WARNING

ALWAYS make sure the table saw is turned **OFF**, disconnected from power, and all moving parts have come to a complete stop before making adjustments to the jig, workpiece, or table saw to avoid serious personal injury from making contact with the spinning blade.



4. Cut a piece of $\frac{3}{4}$ " plywood approximately 2" wide by 9" tall, then mount it on the back support using either wood screws through the back of the support or recessed cap screws and hex nuts through the front (see **Figure 21**).

—If your operation requires the back support to be at an angle, make sure the bottom of this backing board is cut at an angle so that it is parallel with the saw table. You will also need to make accommodations when making the side support backing board in the next step.

Note: *The back support backing board will prevent tear out when making the tenon cuts.*

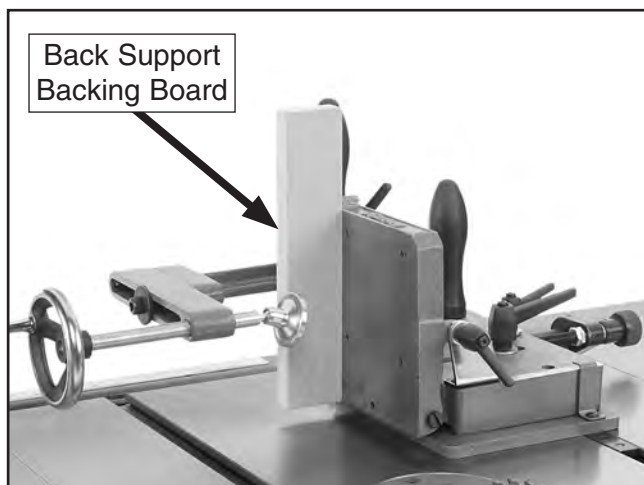

Figure 21. Back support backing board mounted.

5. Cut a piece of plywood that is approximately 5" wide by 9" tall and a minimum of $\frac{3}{4}$ " thick, then mount it to the jig side support, as shown in **Figure 22**.

Note: *The thickness of this backing board can vary, depending upon any distance you need to make up between the jig side support and the saw blade. However, keep in mind that this backing board provides an additional safety barrier between the jig and the saw blade. **Make sure you use it!***

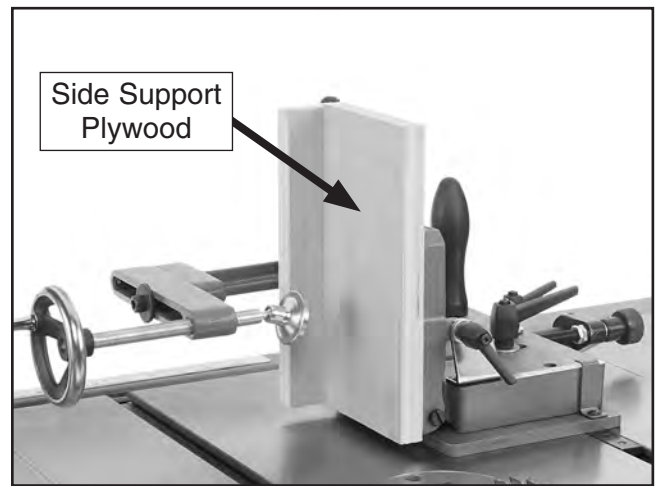

Figure 22. Side support plywood mounted.

⚠ WARNING

ALWAYS move the workpiece completely through the blade to reduce the risk of kick-back. **ALWAYS** turn the saw **OFF**, disconnect it from power, and wait for the blade to come to a complete stop before removing the workpiece or moving the jig to avoid making contact with the spinning blade.



- Place the workpiece firmly against the back and side support backing boards, as shown in **Figure 23**, then use the clamp handwheel to securely hold it in place.

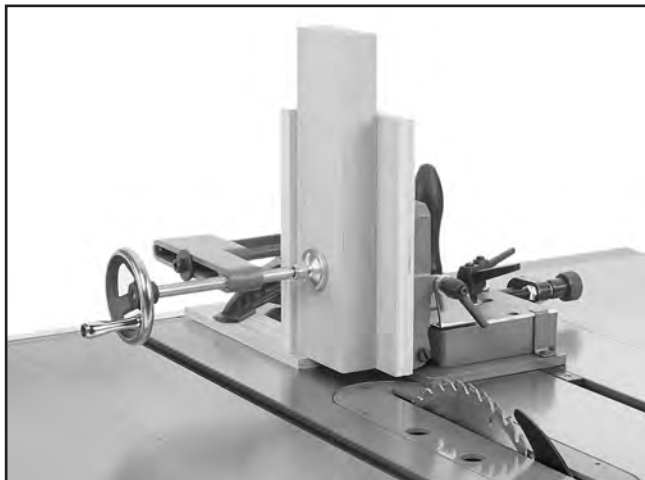

Figure 23. Workpiece correctly mounted to the jig.

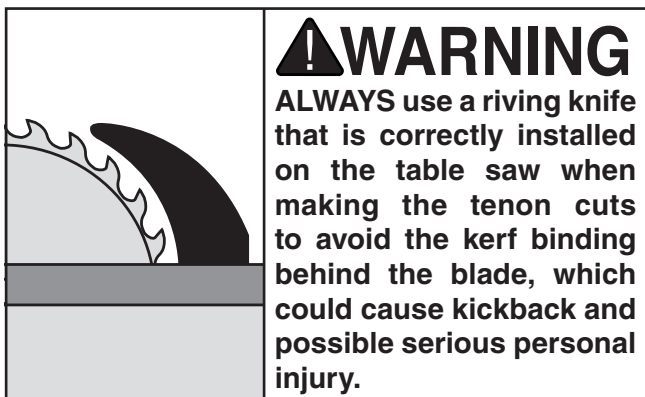

Figure 24. Making the first cheek cut.

- Slide the jig and workpiece up to the saw blade, then use the micro-adjust knob to correctly align the first structural cheek cut mark with the saw blade.

Note: Remember to allow for the width of the kerf when aligning the workpiece. Also, keep the cuts close to the side support backing board, as shown in **Figure 24**, to support the waste piece and reduce the risk of it breaking off during the cut.



- Raise the saw blade to the required depth of cut for the tenon cheek.
- Move the jig and workpiece back away from the blade, then connect the table saw to power and turn it **ON**.
- Firmly grasp **both** handles of the jig, then slowly slide the jig and workpiece through the blade to make the first structural cheek cut (see **Figure 24**).

Note: Do not move the jig and workpiece into the blade quickly or the force of the blade will attempt to lift the jig up and away from the table.

Cutting Tenon Cheeks

- DISCONNECT TABLE SAW FROM POWER!
- Make sure that all jig lock levers are tightened and the workpiece is properly mounted to the jig.



7. Turn the saw **OFF**, disconnect it from power, then wait for the blade to come to a complete stop.
8. Loosen the clamp shoe, remove the workpiece, then move the jig back to the front of the table.
9. Rotate the workpiece 180°, correctly clamp it against the jig, verify the blade alignment for the second structural cheek cut, then repeat **Steps 5–8** to complete the cut (see **Figure 25**).



Figure 25. Making the second cut.

!WARNING

If it is necessary to remove the side support plywood to perform a cut, make sure the metal side support of the jig stays at least 1/2" away from the saw blade at all times. If the jig makes contact with the saw blade, serious personal injury could result and damage will occur to the saw and jig.

10. Position the workpiece for the third and fourth cosmetic cheek cuts, as shown in **Figure 26**, and repeat **Steps 5–8** for each cut.

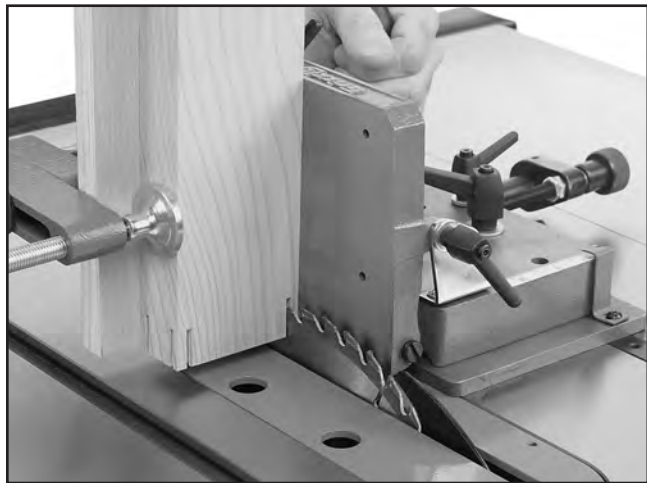

Figure 26. Making the third and fourth cheek cuts.

11. Turn the saw **OFF**, disconnect it from power, wait for the blade to come to a complete stop, then remove the jig and additional base piece from the table.



!WARNING

ALWAYS use a cross-cut saw blade when making the tenon shoulder cuts. Otherwise, the blade can aggressively grab the workpiece causing kickback and possible serious personal injury.

Cutting Tenon Shoulders

The final set of cuts will remove the waste pieces from the previous cuts to produce the shoulders and complete the tenon.

1. DISCONNECT TABLE SAW FROM POWER!
2. Install a cross-cut saw blade.
3. Adjust the blade height to remove the waste pieces of the shoulders, as shown in **Figure 27**.

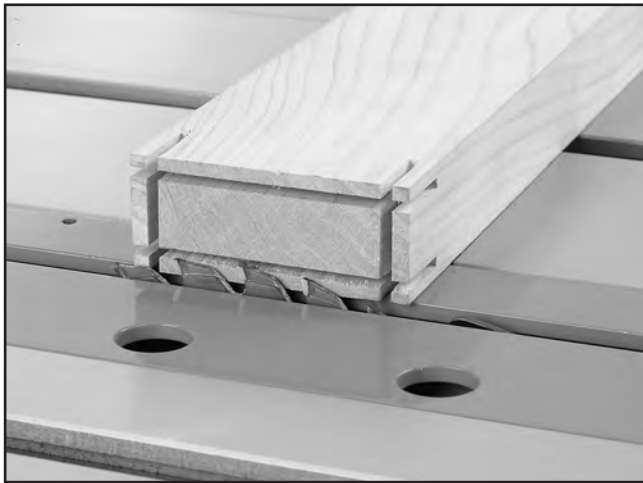

Figure 27. Blade height adjusted for shoulder cut.

4. Install the table saw fence and clamp a stop block to it so that the workpiece can be placed against it to properly align the cut, as shown in **Figure 28**.

Note: Make sure the stop block is far enough behind the blade that the workpiece will not contact it as it reaches the blade, otherwise the workpiece could bind and kickback.

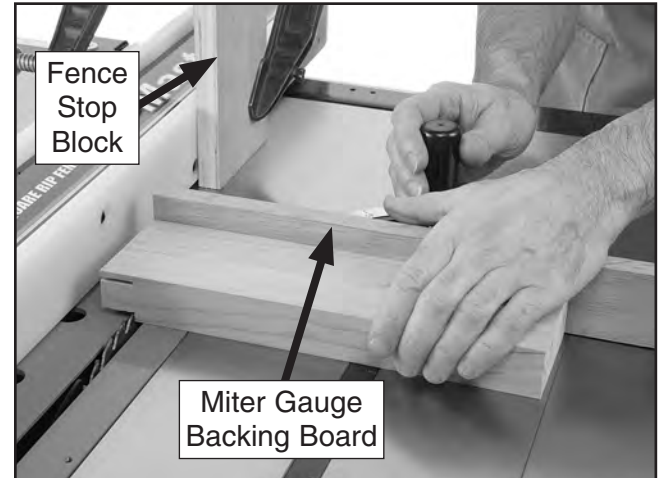

Figure 28. Making a tenon shoulder cut.

5. Attach a backing board to the miter gauge that is aligned even with the end of the workpiece, as shown in **Figure 28**.

Note: This backing board will prevent blade tear out on the workpiece when making the cut.

6. Turn the saw **ON**, then carefully and slowly push the miter gauge forward to make the shoulder cut.
7. Turn the saw **OFF**, wait for the blade to come to a complete stop, then remove the workpiece.
8. Repeat **Steps 3–7** for the remaining three shoulder cuts.

When all the steps of these procedures are successfully performed, your basic tenon is complete.



SECTION 4: ACCESSORIES

- G5562—SLIPIT® 1 Qt. Gel
- G5563—SLIPIT® 12 oz Spray
- G2871—Boeshield® T-9 12 oz Spray
- G2870—Boeshield® T-9 4 oz Spray
- H3788—G96® Gun Treatment 12 oz Spray
- H3789—G96® Gun Treatment 4.5 oz Spray



Figure 29. Recommended products for protecting unpainted cast iron/steel part on machinery.

- G7895—Citrus Degreaser
- G1955—OxiSolv® Blade & Bit Cleaner



Figure 30. G1955 OxiSolv® spray.

Call 1-800-523-4777 To Order

- T20501—Face Shield Crown Protector 4"
- T20502—Face Shield Crown Protector 7"
- T20503—Face Shield Window
- T20448—Economy Clear Safety Glasses
- T20452—"Kirova" Anti-Reflective Glasses
- T20456—"Dakura" Clear Safety Glasses
- H0736—Shop Fox® Safety Glasses

These glasses meet ANSI Z87.1-2003 specifications. Buy extras for visitors or employees. You can't be too careful with shop safety!



Figure 31. Our most popular eye protection.

H7237—Classic Joints with Power Tools

If you think cutting dovetails or making a mortise and tenon is beyond your skills, relax. Take this easy approach for cutting these classic joints, and many more, using common shop machinery. Includes many shop-made jigs. 175 pages.

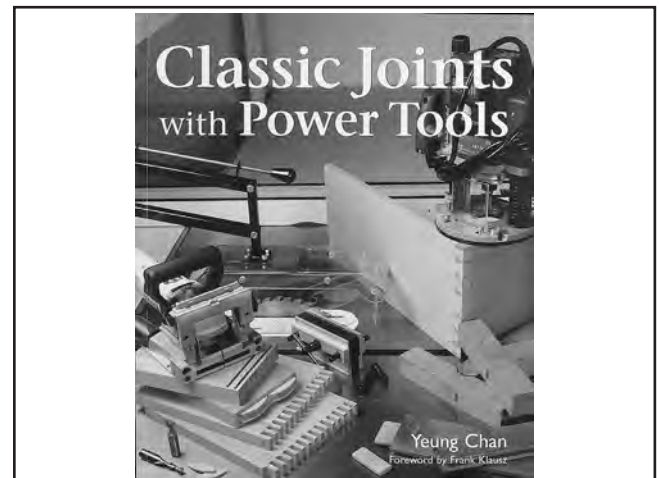

Figure 32. Classic Joints with Power Tools.



G1317—37" Wide Outfeed Roller System

H8875—26" Wide Outfeed Roller System

These unique roller systems fold down easily without tools and snap up in place quickly when needed. Both units have a double level system which lets you set the rollers either in line with the table or slightly below it.



Model G1317 Shown

Figure 2. Outfeed roller system.

G7314—Heavy-Duty Mobile Base

G8684—Extension Kit for Mobile Base

This heavy duty mobile base is rated for up to a 600 lb. capacity.

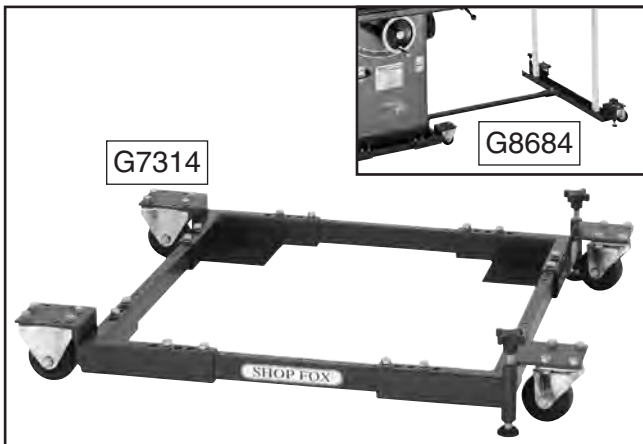

Figure 3. G7314 mobile base and extension kit.

H4332—T4 Silencer for Saw Blades

Woodworkers across the country swear by these blade silencers.

Power Twist® V-Belts

H9815—A 1/2" x 4'

H9817—B 5/8" x 6'

Works with multi-sheave pulleys. Reduces noise!

G4227—Sliding Table for 10" Table Saws

G8010—Sliding Table for 14" Table Saws

Perfect for cutting large sheet stock! The table glides effortlessly on five ball bearing rollers, attaches directly to your saw or shaper table and can be adjusted for precision results. Model G4227 fits our G1023 Series (except G1023SL & G1023SLX), G1035, G1026 and most other cabinet saws and full size shapers. Model G8010 fits our G7209/G7210 14" table saws.

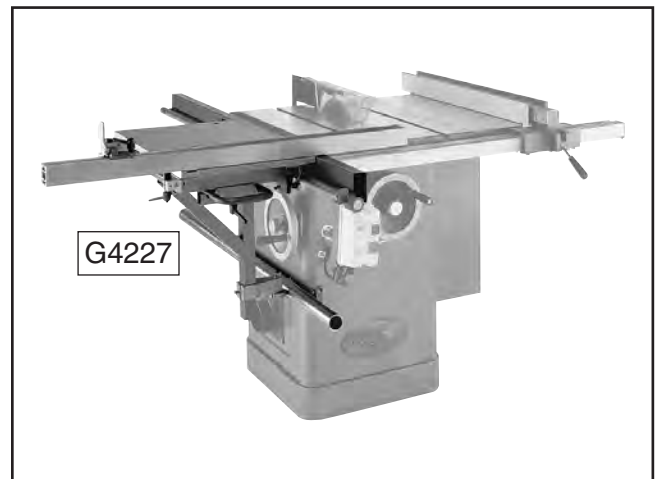

Figure 4. G4227 sliding table attachment.

G4173—1/8 HP Power Feeder

G4173—1/4 HP Power Feeder

G4179—1/2 HP Power Feeder

Installing a power feeder on your table saw will make repetitive cuts much easier and safer. Can be installed on nearly any table saw. Easy to adjust wherever needed, including out of the way when not needed! A must for any production shop.

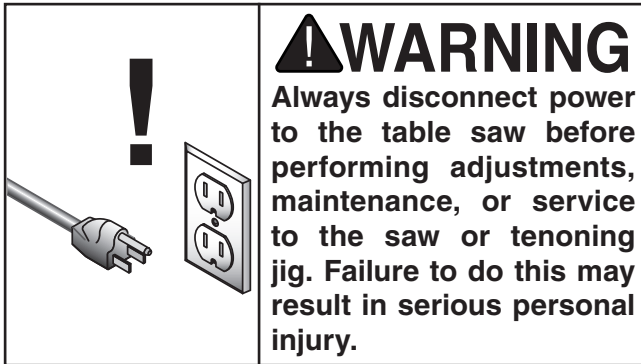

Figure 5. G4179 Power Feeder.

Call 1-800-523-4777 To Order



SECTION 5: MAINTENANCE



Schedule

For optimum performance from your tenoning jig, follow this maintenance schedule and refer to any specific instructions given in this section.

Before Operation Check:

- Loose locks or stop bolts.
- Damaged or worn saw blade.
- Worn or damaged table saw wires.
- Any other unsafe condition.

After Operation Maintenance:

- Clean the tenoning jig.
- Lubricate the jig pivot points.

Cleaning

Cleaning the Model H7583 is relatively easy. Clean off the wood chips and sawdust, then wipe off the remaining dust with a dry cloth. If any resin has built up, use a resin dissolving cleaner to remove it. Treat all unpainted cast iron with a non-staining rust-protectant after cleaning.

Lubrication & Storage

After thoroughly cleaning the tenoning jig, use a light machine oil to lubricate all of the pivot points on the jig, then wipe away the excess to avoid sawdust build-up at these locations.

When not in use, store the jig on a flat, dry surface that is protected from adverse elements. Cover the jig to prevent dust build-up between uses.



SECTION 6: PARTS

Parts Breakdown

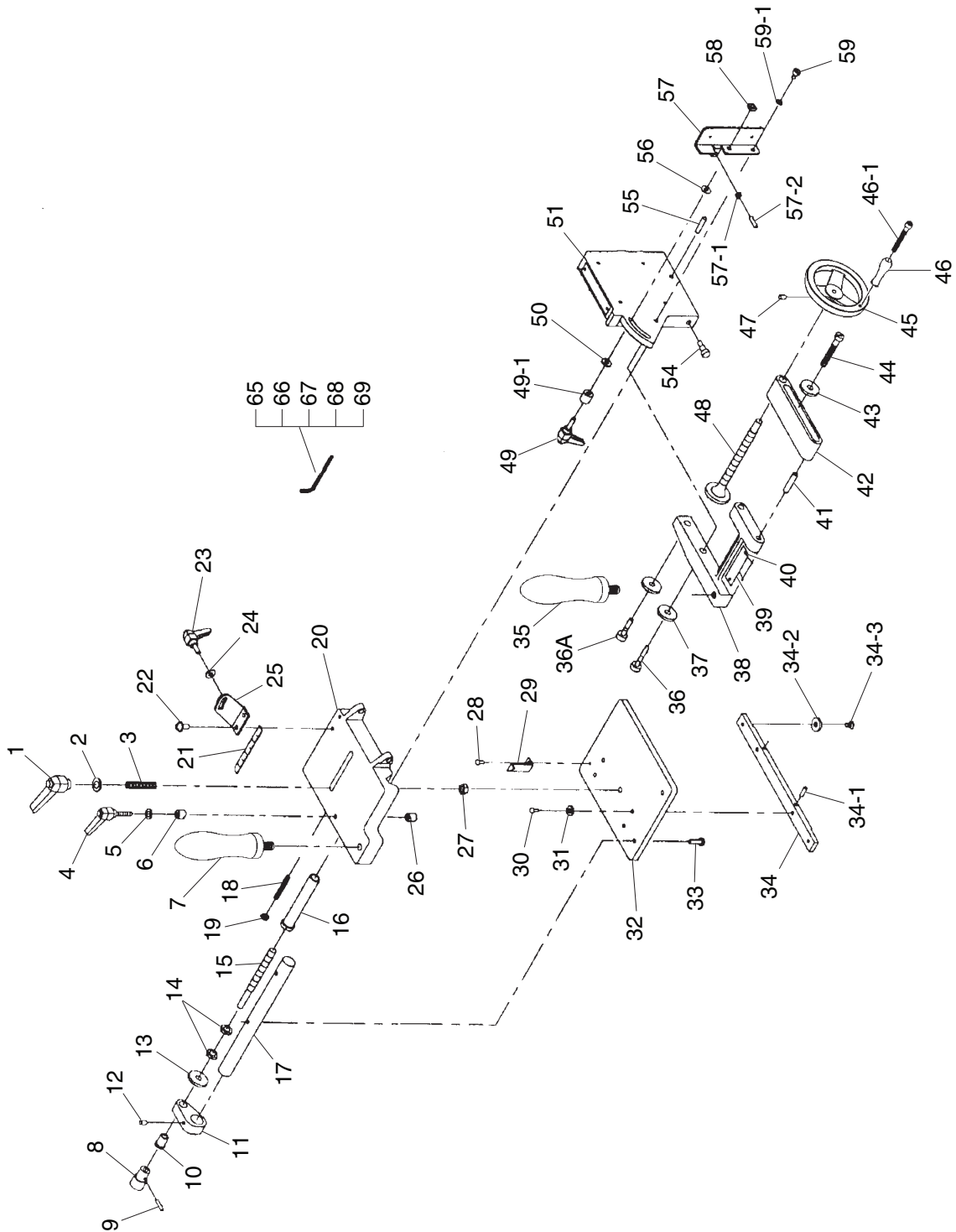

REF	PART #	DESCRIPTION
1	PH7583001	LOCK LEVER M8-1.25
2	PH7583002	SPECIAL WASHER 15/16" OD
3	PSS102M	SET SCREW M8-1.25 X 55
4	PH7583004	LOCK LEVER M6-1 X 28
5	PW03M	FLAT WASHER 6MM
6	PH7583006	LOCK BUSHING
7	PH7583007	HANDLE M10-1.5 X 20
8	PH7583008	KNURLED KNOB 10MM PINNED
9	PRP42M	ROLL PIN 3 X 20
10	PH7583010	BUSHING
11	PH7583011	MICRO-ADJUST COLLAR
12	PSS01M	SET SCREW M6-1 X 10
13	PH7583013	NYLON WASHER 10MM
14	PN02M	HEX NUT M10-1.5
15	PH7583015	THREADED SHAFT M10-1.5 X 116
16	PH7583016	GUIDE BUSHING
17	PH7583017	GUIDE ROD
18	PSS85M	SET SCREW M6-1 X 45
19	PN01M	HEX NUT M6-1
20	PH7583020	SLIDE PLATE
21	PH7583021	SCALE
22	PS09M	PHLP HD SCR M5-.8 X 10
23	PH7583004	LOCK LEVER M6-1 X 28
24	PW03M	FLAT WASHER 6MM
25	PH7583025	BRACKET
26	PH7583026	LOCK BUSHING M6-1
27	PN03M	HEX NUT M8-1.25
28	PS07M	PHLP HD SCR M4-.7 X 8
29	PH7583029	POINTER
30	PSBS05M	BUTTON HD CAP SCR M6-1 X 20
31	PLW03M	LOCK WASHER 6MM
32	PH7583032	BASE PLATE
33	PSBS05M	BUTTON HD CAP SCR M6-1 X 20
34	PH7583034	GUIDE BAR
34-1	PH7583034-1	PILOT SET SCREW M5-.8 X 16
34-2	PH7583034-2	T-SLOT WASHER

REF	PART #	DESCRIPTION
34-3	PH7583034-3	FLAT HD SCR 1/4-28 X 5/16
35	PH7583007	HANDLE M10-1.5 X 20
36	PSB64M	CAP SCREW M10-1.5 X 25
36A	PSB61M	CAP SCREW M10-1.5 X 20
37	PLW06M	LOCK WASHER 10MM
38	PH7583038	CLAMP BRACKET
39	PH7583039	WARNING LABEL
40	PH7583040	RIVET 2 X 4
41	PH7583041	ROLL PIN 3/8" X 2"
42	PH7583042	CLAMP ARM
43	PW01M	FLAT WASHER 8MM
44	PSB05M	CAP SCREW M8-1.25 X 50
45	PH7583045	HANDWHEEL
46	PH7583046	HANDWHEEL HANDLE
46-1	PH7583046-1	SPECIAL SCREW M6-1 X 55
47	PSS03M	SET SCREW M6-1 X 8
48	PH7583048	CLAMP SHOE
49	PH7583004	LOCK LEVER M6-1 X 28
49-1	PH7583006	LOCK BUSHING
50	PW03M	FLAT WASHER 6MM
51	PH7583051	SIDE SUPPORT
54	PH7583054	SHOULDER SCREW M6 X 20
55	PSS12M	SET SCREW M6-1 X 25
56	PW03M	FLAT WASHER 6MM
57	PH7583057	BACK SUPPORT
57-1	PN06M	HEX NUT M5-.8
57-2	PSS57M	SET SCREW M5-.8 X 20
58	PSN02M	SQUARE NUT M6-1
59	PH7583059	SPECIAL SLOT SCREW M5-.8 X 10
59-1	PH7583059-1	WAVY WASHER 6MM
65	PAW03M	HEX WRENCH 3MM
66	PAW04M	HEX WRENCH 4MM
67	PAW06M	HEX WRENCH 6MM
68	PAW08M	HEX WRENCH 8MM
69	PAW02.5M	HEX WRENCH 2.5MM



WARRANTY CARD

Name _____
 Street _____
 City _____ State _____ Zip _____
 Phone # _____ Email _____ Invoice # _____
 Model # _____ Order # _____ Serial # _____

The following information is given on a voluntary basis. It will be used for marketing purposes to help us develop better products and services. **Of course, all information is strictly confidential.**

1. How did you learn about us?

Advertisement Friend Catalog
 Card Deck Website Other:

2. Which of the following magazines do you subscribe to?

<input type="checkbox"/> Cabinet Maker	<input type="checkbox"/> Popular Mechanics	<input type="checkbox"/> Today's Homeowner
<input type="checkbox"/> Family Handyman	<input type="checkbox"/> Popular Science	<input type="checkbox"/> Wood
<input type="checkbox"/> Hand Loader	<input type="checkbox"/> Popular Woodworking	<input type="checkbox"/> Wooden Boat
<input type="checkbox"/> Handy	<input type="checkbox"/> Practical Homeowner	<input type="checkbox"/> Woodshop News
<input type="checkbox"/> Home Shop Machinist	<input type="checkbox"/> Precision Shooter	<input type="checkbox"/> Woodsmith
<input type="checkbox"/> Journal of Light Cont.	<input type="checkbox"/> Projects in Metal	<input type="checkbox"/> Woodwork
<input type="checkbox"/> Live Steam	<input type="checkbox"/> RC Modeler	<input type="checkbox"/> Woodworker West
<input type="checkbox"/> Model Airplane News	<input type="checkbox"/> Rifle	<input type="checkbox"/> Woodworker's Journal
<input type="checkbox"/> Modeltec	<input type="checkbox"/> Shop Notes	<input type="checkbox"/> Other:
<input type="checkbox"/> Old House Journal	<input type="checkbox"/> Shotgun News	

3. What is your annual household income?

\$20,000-\$29,000 \$30,000-\$39,000 \$40,000-\$49,000
 \$50,000-\$59,000 \$60,000-\$69,000 \$70,000+

4. What is your age group?

20-29 30-39 40-49
 50-59 60-69 70+

5. How long have you been a woodworker/metalworker?

0-2 Years 2-8 Years 8-20 Years 20+ Years

6. How many of your machines or tools are Grizzly?

0-2 3-5 6-9 10+

7. Do you think your machine represents a good value?

Yes No

8. Would you recommend Grizzly Industrial to a friend?

Yes No

9. Would you allow us to use your name as a reference for Grizzly customers in your area?

Note: We never use names more than 3 times.

Yes No

10. Comments: _____

CUT ALONG DOTTED LINE

FOLD ALONG DOTTED LINE



Place
Stamp
Here



GRIZZLY INDUSTRIAL, INC.
P.O. BOX 2069
BELLINGHAM, WA 98227-2069



FOLD ALONG DOTTED LINE

Send a Grizzly Catalog to a friend:

Name _____

Street _____

City _____ State _____ Zip _____

TAPE ALONG EDGES--PLEASE DO NOT STAPLE

WARRANTY AND RETURNS

Grizzly Industrial, Inc. warrants every product it sells for a period of **1 year** to the original purchaser from the date of purchase. This warranty does not apply to defects due directly or indirectly to misuse, abuse, negligence, accidents, repairs or alterations or lack of maintenance. This is Grizzly's sole written warranty and any and all warranties that may be implied by law, including any merchantability or fitness, for any particular purpose, are hereby limited to the duration of this written warranty. We do not warrant or represent that the merchandise complies with the provisions of any law or acts unless the manufacturer so warrants. In no event shall Grizzly's liability under this warranty exceed the purchase price paid for the product and any legal actions brought against Grizzly shall be tried in the State of Washington, County of Whatcom.

We shall in no event be liable for death, injuries to persons or property or for incidental, contingent, special, or consequential damages arising from the use of our products.

To take advantage of this warranty, contact us by mail or phone and give us all the details. We will then issue you a "Return Number," which must be clearly posted on the outside as well as the inside of the carton. We will not accept any item back without this number. Proof of purchase must accompany the merchandise.

The manufacturers reserve the right to change specifications at any time because they constantly strive to achieve better quality equipment. We make every effort to ensure that our products meet high quality and durability standards and we hope you never need to use this warranty.

Please feel free to write or call us if you have any questions about the machine or the manual.

Thank you again for your business and continued support. We hope to serve you again soon.

grizzly.com[®]
TOOL WEBSITE

Buy Direct and Save with Grizzly[®] – Trusted, Proven and a Great Value!
~Since 1983~

*Visit Our Website Today For
Current Specials!*

**ORDER
24 HOURS A DAY!
1-800-523-4777**

