

# READ THIS FIRST



For questions or help with this product contact Tech Support at (570) 546-9663 or [techsupport@grizzly.com](mailto:techsupport@grizzly.com)

## Model G9980

### \*\*\*IMPORTANT UPDATE\*\*\*

For Machines Mfd. Since 01/22  
and Owner's Manual Printed 11/05

The following change was made since the owner's manual was printed:

- The upper frame cover now has (4) 5" dust ports welded to it.

Aside from this information, all other content in the owner's manual applies and **MUST** be read and understood for your own safety. **IMPORTANT: Keep this update with the owner's manual for future reference.**

For questions or help, contact our Tech Support at (570) 546-9663 or [techsupport@grizzly.com](mailto:techsupport@grizzly.com).

### New Frame Cover & Dust Ports

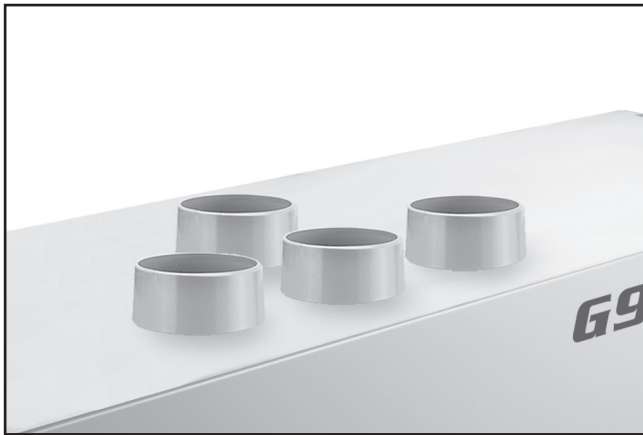

### Old Frame Cover & Dust Ports

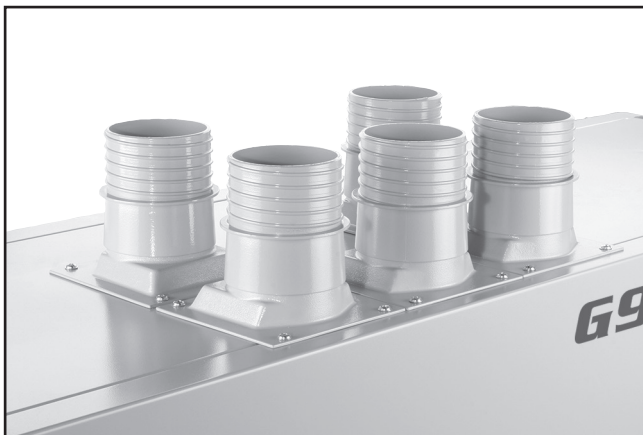

### Revised Specifications

#### Product Dimensions:

Height..... 65 in.

#### Shipping Dimensions:

Height..... 77 in.

#### Main Specifications:

##### Other Related Information

Number of Dust Ports..... 4  
Dust Port Size..... 5 in.

### Revised Parts

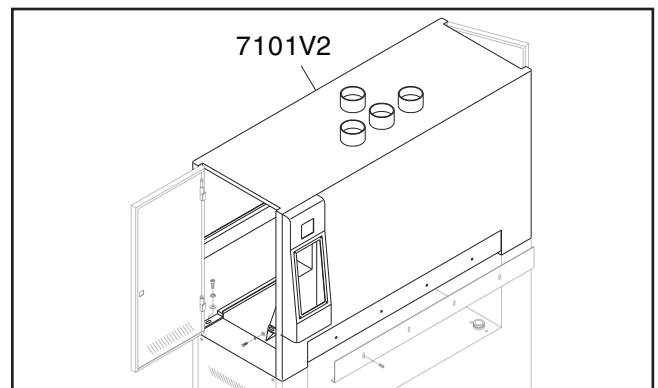

REF	PART #	DESCRIPTION
7101V2	P99807101V2	UPPER FRAME COVER V2.01.22



COPYRIGHT © DECEMBER, 2021 BY GRIZZLY INDUSTRIAL, INC.  
**WARNING: NO PORTION OF THIS MANUAL MAY BE REPRODUCED IN ANY SHAPE OR FORM WITHOUT THE WRITTEN APPROVAL OF GRIZZLY INDUSTRIAL, INC.**  
#CS22199 PRINTED IN TAIWAN

# SECTION 3: SET UP

## Unpacking

This machine was carefully packaged for safe transport. When unpacking, separate all enclosed items from packaging materials and inspect them for shipping damage. ***If items are damaged, please call us immediately at (570) 546-9663.***

**IMPORTANT:** Save all packaging materials until you are completely satisfied with the machine and have resolved any issues between Grizzly or the shipping agent. ***You MUST have the original packaging to file a freight claim. It is also extremely helpful if you need to return your machine later.***

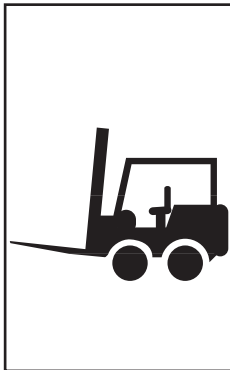

**⚠ WARNING**  
**HEAVY LIFT!**  
Straining or crushing injury may occur from improperly lifting machine or some of its parts. To reduce this risk, use a forklift (or other lifting equipment) rated for weight of this machine.



**⚠ WARNING**  
To reduce your risk of serious injury, read this entire manual **BEFORE** using machine.

## Inventory

The following is a list of items shipped with your machine. Before beginning setup, lay these items out and inventory them.

If any non-proprietary parts are missing (e.g. a nut or a washer), we will gladly replace them; or for the sake of expediency, replacements can be obtained at your local hardware store.

Inventory (Figure 9)	Qty
A. Sanding Belts 100-Grit, 180-Grit.....	1 Ea.
B. Platen Graphite Flaps.....	2
C. Platen Felt .....	1
D. Tool Box .....	1
—Phillips Head Screwdriver #2.....	1
—Flat Screwdriver 1/4" .....	1
—Open-End Wrenches 8/10, 12/14, 17/19mm .....	1 Ea.
—Metric Hex Wrench Set (10-Pc.).....	1
—Door Keys .....	2
—Ceramic Limit Switch Rub Rods .....	2
—Flexible Grease Gun Extension.....	1
—Platen Removal Tool .....	1

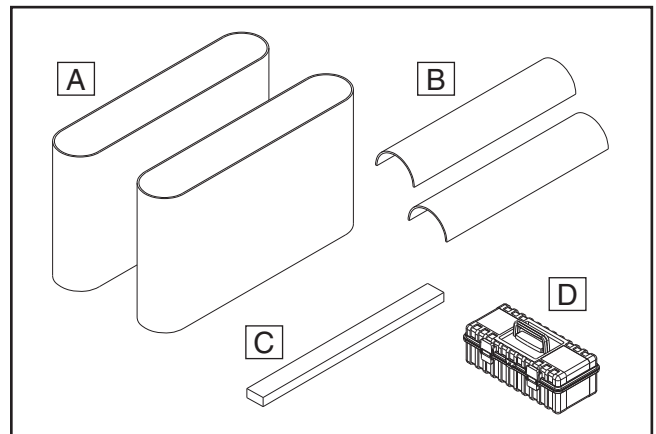

Figure 9. Inventory.

## NOTICE

If you cannot find item, carefully check around/inside machine and packaging. Often, items get lost in packaging materials or they are pre-installed at factory.



## Air Line Installation

Use the following steps to install an air line to the air inlet and regulator.

To install air line:

1. Connect hose from air compressor to air inlet (see **Figure 10**) on regulator.

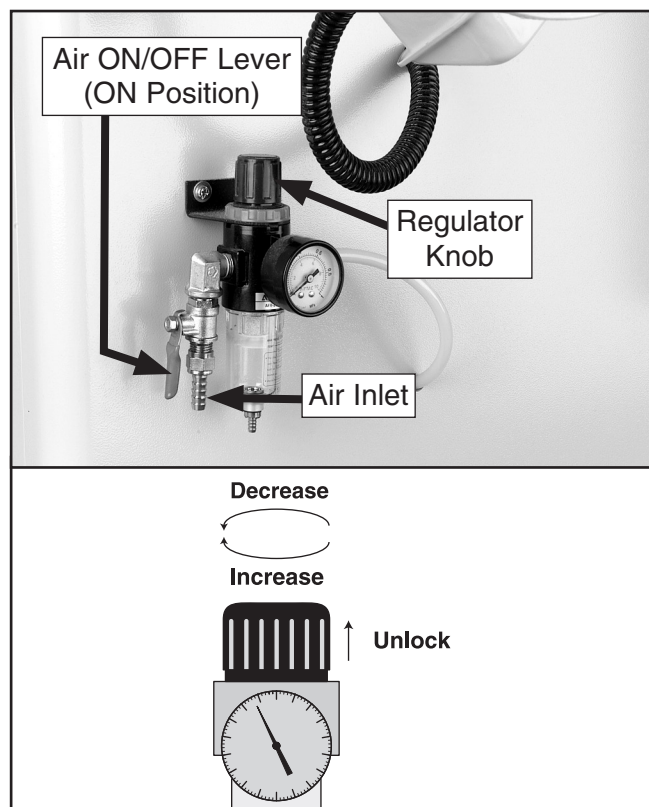

**Figure 10.** Air inlet and regulator components.

2. Make sure red handle on regulator is in ON position (parallel with air inlet).
3. Lift regulator knob (see **Figure 10**) and turn it until air pressure gauge reads 75 PSI.

**Note:** Turn knob clockwise to increase air pressure and counterclockwise to decrease air pressure.

4. Push regulator knob down until it snaps.

## Dust Collection

### ⚠ CAUTION

This machine creates a lot of wood chips/dust during operation. Breathing airborne dust on a regular basis can result in permanent respiratory illness. Reduce your risk by wearing a respirator and capturing the dust with a dust-collection system.

### Minimum CFM at Dust Ports: 2400 CFM

Do not confuse this CFM recommendation with the rating of the dust collector. To determine the CFM at the dust port, you must consider these variables: (1) CFM rating of the dust collector, (2) hose type and length between the dust collector and the machine, (3) number of branches or wyes, and (4) amount of other open lines throughout the system. Explaining how to calculate these variables is beyond the scope of this manual. Consult an expert or purchase a good dust collection "how-to" book.

To connect dust collection system to machine:

1. Using 5" hose clamps, secure hoses from dust collection system to dust ports (see **Figure 11**).

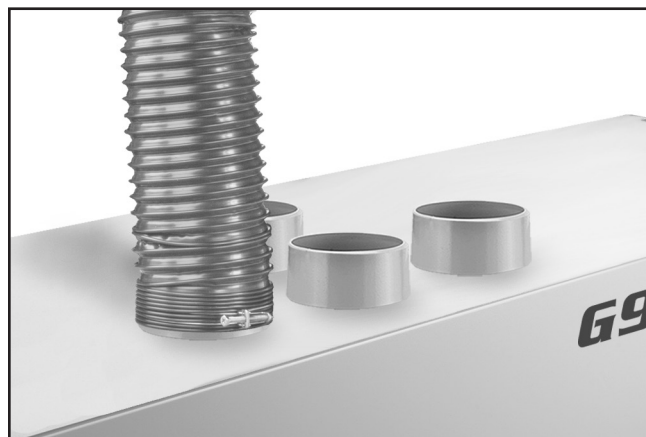

**Figure 11.** Example of hose attached to port.

2. Tug hoses to make sure they do not come off.

**Note:** A tight fit is necessary for proper performance.



# *grizzly.com*<sup>®</sup>

**TOOL WEBSITE**

Buy Direct and Save with Grizzly<sup>®</sup> – Trusted, Proven and a Great Value!  
~Since 1983~

*Visit Our Website Today For  
Current Specials!*

**ORDER  
24 HOURS A DAY!  
1-800-523-4777**



# READ THIS FIRST



Model G9979/G9980

\*\*\*IMPORTANT UPDATE\*\*\*

For Machines Mfd. Since January, 2014  
& Owner's Manual Printed November, 2005

For questions or help with this product contact Tech Support at (570) 546-9663 or [techsupport@grizzly.com](mailto:techsupport@grizzly.com)

The following changes were made to this machine since the owner's manual was printed:

- Obtained CSA certification meeting CSA C22.2 #105-1953 and UL 987-7th standards.
- Changed sanding motor contactor and relay, conveyor contactor, transformer, and terminal bar.
- Changed models of 440V conversion kit components.
- Changed circuit requirements.
- Changed machine and 220V electrical cabinet wiring.
- Replaced oscillation diaphragm assembly with an air cylinder (P/N 6139).

**Note:** At the top of each page is a note that indicates which page it replaces or changes in the original manual. On the parts list, the new parts are designated with a "V2" or "V3".

Aside from this information, all other content in the owner's manual applies and **MUST** be read and understood for your own safety. **IMPORTANT: Keep this update with the owner's manual for future reference.** For questions or help, contact our Tech Support at (570) 546-9663 or [techsupport@grizzly.com](mailto:techsupport@grizzly.com).

## Electrical Cabinet Changed Parts (Changes Page 70)

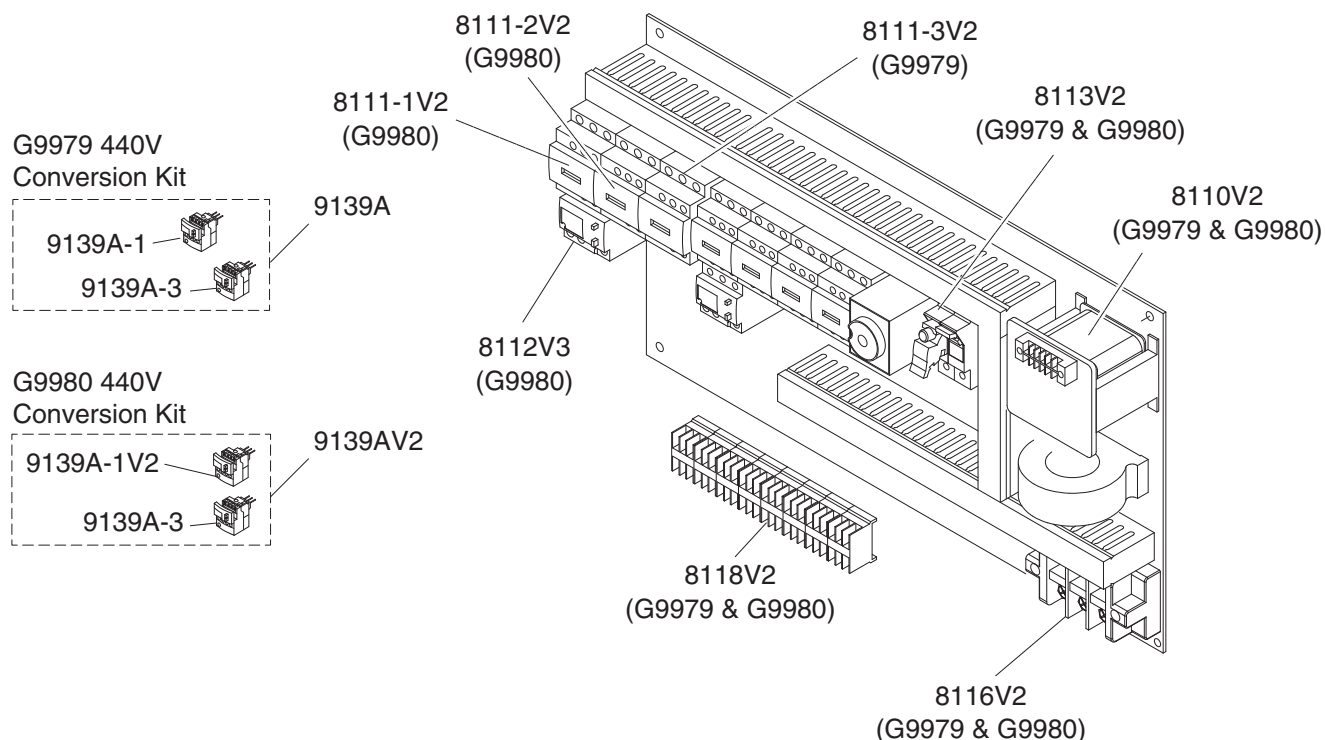

COPYRIGHT © NOVEMBER, 2010 BY GRIZZLY INDUSTRIAL, INC., REVISED JULY, 2014 (TS)

**WARNING: NO PORTION OF THIS MANUAL MAY BE REPRODUCED IN ANY SHAPE OR FORM WITHOUT THE WRITTEN APPROVAL OF GRIZZLY INDUSTRIAL, INC.**

#TR13507 PRINTED IN TAIWAN

## Electrical Cabinet Changed Parts List (*Changes Page 71*)

### Common Parts

REF	PART #	DESCRIPTION
8110V2	P99798110V2	TRANSFORMER SUEN SP-TB8-20250 0-440 V2.09.10
8111-1V2	P99808111-1V2	CONTACTOR SCHN LC1D40A 220V V2.09.10
8111-2V2	P99808111-2V2	CONTACTOR SCHN LC1D40A 220V V2.09.10
8111-3V2	P99798111-3V2	CONTACTOR SCHN LC1D25 220V V2.09.10
8112V3	P99808112V3	OL RELAY SCHN LRD340 30-40A V3.04.13
8113V2	P99798113V2	FUSE 4A W/HOUSING V2.09.10
8116V2	P99798116V2	TERMINAL BAR 25P V2.09.10
8118V2	P99798118V2	TERMINAL BAR 4P V2.09.10

### G9979 440V Conversion Kit

REF	PART #	DESCRIPTION
9139A	P99799139A	440V CONVERSION KIT
9139A-1	P99799139A-1	OL RELAY SCHN LR3D21 12-18A
9139A-3	P99799139A-3	OL RELAY SCHN LR3D08 2.5-4A

### G9980 440V Conversion Kit

REF	PART #	DESCRIPTION
9139AV2	P99809139AV2	440V CONVERSION KIT V2.09.10
9139A-1V2	P99809139A-1V2	OL RELAY SCHN LR3D325 17-25A V2.09.10
9139A-3	P99809139A-3	OL RELAY SCHN LR3D08 2.5-4A



*Replaces Page 12*  
**SECTION 1: SAFETY**

---

## **For Your Own Safety, Read Instruction Manual Before Operating This Machine**

The purpose of safety symbols is to attract your attention to possible hazardous conditions. This manual uses a series of symbols and signal words intended to convey the level of importance of the safety messages. The progression of symbols is described below. Remember that safety messages by themselves do not eliminate danger and are not a substitute for proper accident prevention measures. Always use common sense and good judgment.



Indicates an imminently hazardous situation which, if not avoided, **WILL** result in death or serious injury.



Indicates a potentially hazardous situation which, if not avoided, **COULD** result in death or serious injury.



Indicates a potentially hazardous situation which, if not avoided, **MAY** result in minor or moderate injury. It may also be used to alert against unsafe practices.

***NOTICE***

This symbol is used to alert the user to useful information about proper operation of the machine.

## **Safety Instructions for Machinery**



**OWNER'S MANUAL.** Read and understand this owner's manual **BEFORE** using machine.

**TRAINED OPERATORS ONLY.** Untrained operators have a higher risk of being hurt or killed. Only allow trained/supervised people to use this machine. When machine is not being used, disconnect power, remove switch keys, or lock-out machine to prevent unauthorized use—especially around children. Make workshop kid proof!

**DANGEROUS ENVIRONMENTS.** Do not use machinery in areas that are wet, cluttered, or have poor lighting. Operating machinery in these areas greatly increases the risk of accidents and injury.

**MENTAL ALERTNESS REQUIRED.** Full mental alertness is required for safe operation of machinery. Never operate under the influence of drugs or alcohol, when tired, or when distracted.

**ELECTRICAL EQUIPMENT INJURY RISKS.** You can be shocked, burned, or killed by touching live electrical components or improperly grounded machinery. To reduce this risk, only allow qualified service personnel to do electrical installation or repair work, and always disconnect power before accessing or exposing electrical equipment.

**DISCONNECT POWER FIRST.** Always disconnect machine from power supply **BEFORE** making adjustments, changing tooling, or servicing machine. This prevents an injury risk from unintended startup or contact with live electrical components.

**EYE PROTECTION.** Always wear ANSI-approved safety glasses or a face shield when operating or observing machinery to reduce the risk of eye injury or blindness from flying particles. Everyday eyeglasses are **NOT** approved safety glasses.



## WARNING

**WEARING PROPER APPAREL.** Do not wear clothing, apparel or jewelry that can become entangled in moving parts. Always tie back or cover long hair. Wear non-slip footwear to avoid accidental slips, which could cause loss of workpiece control.

**HAZARDOUS DUST.** Dust created while using machinery may cause cancer, birth defects, or long-term respiratory damage. Be aware of dust hazards associated with each workpiece material, and always wear a NIOSH-approved respirator to reduce your risk.

**HEARING PROTECTION.** Always wear hearing protection when operating or observing loud machinery. Extended exposure to this noise without hearing protection can cause permanent hearing loss.

**REMOVE ADJUSTING TOOLS.** Tools left on machinery can become dangerous projectiles upon startup. Never leave chuck keys, wrenches, or any other tools on machine. Always verify removal before starting!

**USE CORRECT TOOL FOR THE JOB.** Only use this tool for its intended purpose—do not force it or an attachment to do a job for which it was not designed. Never make unapproved modifications—modifying tool or using it differently than intended may result in malfunction or mechanical failure that can lead to personal injury or death!

**AWKWARD POSITIONS.** Keep proper footing and balance at all times when operating machine. Do not overreach! Avoid awkward hand positions that make workpiece control difficult or increase the risk of accidental injury.

**CHILDREN & BYSTANDERS.** Keep children and bystanders at a safe distance from the work area. Stop using machine if they become a distraction.

**GUARDS & COVERS.** Guards and covers reduce accidental contact with moving parts or flying debris. Make sure they are properly installed, undamaged, and working correctly.

**FORCING MACHINERY.** Do not force machine. It will do the job safer and better at the rate for which it was designed.

**NEVER STAND ON MACHINE.** Serious injury may occur if machine is tipped or if the cutting tool is unintentionally contacted.

**STABLE MACHINE.** Unexpected movement during operation greatly increases risk of injury or loss of control. Before starting, verify machine is stable and mobile base (if used) is locked.

**USE RECOMMENDED ACCESSORIES.** Consult this owner's manual or the manufacturer for recommended accessories. Using improper accessories will increase the risk of serious injury.

**UNATTENDED OPERATION.** To reduce the risk of accidental injury, turn machine **OFF** and ensure all moving parts completely stop before walking away. Never leave machine running while unattended.

**MAINTAIN WITH CARE.** Follow all maintenance instructions and lubrication schedules to keep machine in good working condition. A machine that is improperly maintained could malfunction, leading to serious personal injury or death.

**CHECK DAMAGED PARTS.** Regularly inspect machine for any condition that may affect safe operation. Immediately repair or replace damaged or mis-adjusted parts before operating machine.

**MAINTAIN POWER CORDS.** When disconnecting cord-connected machines from power, grab and pull the plug—NOT the cord. Pulling the cord may damage the wires inside. Do not handle cord/plug with wet hands. Avoid cord damage by keeping it away from heated surfaces, high traffic areas, harsh chemicals, and wet/damp locations.

**EXPERIENCING DIFFICULTIES.** If at any time you experience difficulties performing the intended operation, stop using the machine! Contact our Technical Support at (570) 546-9663.



# Additional Safety for Wide Belt Sanders

## **WARNING**

Serious injury or death can occur from hands getting trapped between workpiece and conveyor table, getting entangled in rotating parts inside machine, or lacerated by sanding drum. Workpieces thrown by sander can strike nearby operators. Long-term respiratory damage can occur from using sander without proper use of a respirator and an adequate dust collection system. To minimize risk of getting hurt or killed, anyone operating machine **MUST** completely heed hazards and warnings below.

**FEEDING WORKPIECE.** DO NOT place fingers under bottom of workpiece while feeding it into sander. Fingers can become pinched between workpiece and conveyor.

**ENTANGLEMENT HAZARDS.** DO NOT wear loose clothing, gloves, or jewelry, and tie back long hair. Never reach inside operating machine or try clearing jammed workpiece. Keep all guards in place and secure, and all doors closed.

**SANDING DRUM CONTACT.** Rotating sandpaper can remove a large amount of flesh in a few seconds. Keep hands away from rotating sanding drum(s) during operation. Never touch moving sandpaper on purpose.

**WORKPIECE KICKBACK.** A workpiece can be ejected out the front of sander at high rate of speed, and hit operator or bystanders. Never stand in-line with workpiece, never feed more than one workpiece at a time, and always adjust pressure rollers below sanding roller.

**MINIMUM STOCK DIMENSION.** To avoid kick-back, never sand workpieces below minimum specifications listed in **Data Sheet**.

**ADJUSTMENTS/MAINTENANCE.** Make sure machine is turned **OFF**, disconnected from power and air, and all moving parts are completely stopped before doing adjustments or maintenance.

**SANDING DUST.** Sanding creates large amounts of dust and flying chips that can lead to eye injury or respiratory illness. Reduce risk of these hazards by wearing approved eye and respiratory protection when using sander.

**DUST COLLECTION.** Never operate without adequate dust collection system in place and running. Proper dust collection reduces dust in work area, which decreases risk of long-term respiratory damage, but it is not a substitute for using a respirator.

## **WARNING**

Like all machinery there is potential danger when operating this machine. Accidents are frequently caused by lack of familiarity or failure to pay attention. Use this machine with respect and caution to decrease the risk of operator injury. If normal safety precautions are overlooked or ignored, serious personal injury may occur.

## **CAUTION**

No list of safety guidelines can be complete. Every shop environment is different. Always consider safety first, as it applies to your individual working conditions. Use this and other machinery with caution and respect. Failure to do so could result in serious personal injury, damage to equipment, or poor work results.



# SECTION 2: POWER SUPPLY

## Availability

Before installing the machine, consider the availability and proximity of the required power supply circuit. If an existing circuit does not meet the requirements for this machine, a new circuit must be installed. To minimize the risk of electrocution, fire, or equipment damage, installation work and electrical wiring must be done by an electrician or qualified service personnel in accordance with all applicable codes and standards.

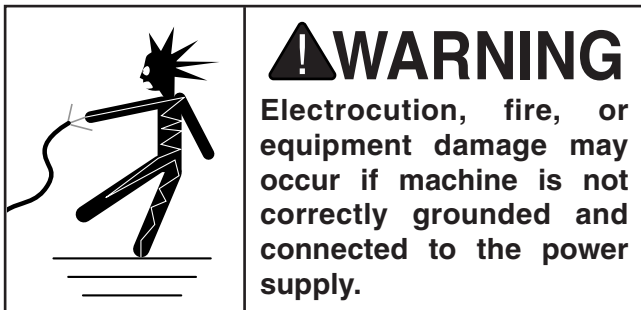

## Full-Load Current Rating

The full-load current rating is the amperage a machine draws at 100% of the rated output power. On machines with multiple motors, this is the amperage drawn by the largest motor or sum of all motors and electrical devices that might operate at one time during normal operations.

### G9979:

**Full-Load Current Rating at 230V ..... 54 Amps**

**Full-Load Current Rating at 460V ..... 27 Amps**

### G9980:

**Full-Load Current Rating at 230V ..... 66 Amps**

**Full-Load Current Rating at 460V ..... 33 Amps**

The full-load current is not the maximum amount of amps that the machine will draw. If the machine is overloaded, it will draw additional amps beyond the full-load rating.

If the machine is overloaded for a sufficient length of time, damage, overheating, or fire may result—especially if connected to an undersized circuit. To reduce the risk of these hazards, avoid overloading the machine during operation and make sure it is connected to a power supply circuit that meets the requirements in the following section.

## Circuit Information

A power supply circuit includes all electrical equipment between the breaker box or fuse panel in the building and the machine. The power supply circuit used for this machine must be sized to safely handle the full-load current drawn from the machine for an extended period of time. (If this machine is connected to a circuit protected by fuses, use a time delay fuse marked D.)



## In Addition to Page 15

**Note:** The circuit requirements listed in this manual apply to a dedicated circuit—where only one machine will be running at a time. If this machine will be connected to a shared circuit where multiple machines will be running at the same time, consult a qualified electrician to ensure that the circuit is properly sized for safe operation.

### G9979 230V Circuit Requirements

This machine is prewired to operate on a power supply circuit that has a verified ground and meets the following requirements:

**Nominal Voltage** ..... 220V, 230V, 240V  
**Cycle** ..... 60 Hz  
**Phase** ..... 3-Phase  
**Circuit Rating** ..... 70 Amps

### G9979 460V Circuit Requirements

This machine can be converted to operate on a power supply circuit that has a verified ground and meets the requirements listed below. (Refer to **Voltage Conversion** instructions for details.)

**Nominal Voltage** ..... 440V, 460V, 480V  
**Cycle** ..... 60 Hz  
**Phase** ..... 3-Phase  
**Circuit Rating** ..... 40 Amps

### G9980 230V Circuit Requirements

This machine is prewired to operate on a power supply circuit that has a verified ground and meets the following requirements:

**Nominal Voltage** ..... 220V, 230V, 240V  
**Cycle** ..... 60 Hz  
**Phase** ..... 3-Phase  
**Circuit Rating** ..... 90 Amps

### G9980 460V Circuit Requirements

This machine can be converted to operate on a power supply circuit that has a verified ground and meets the requirements listed below. (Refer to **Voltage Conversion** instructions for details.)

**Nominal Voltage** ..... 440V, 460V, 480V  
**Cycle** ..... 60 Hz  
**Phase** ..... 3-Phase  
**Circuit Rating** ..... 50 Amps

## Connection Type

A permanently connected (hardwired) power supply is typically installed with wires running through mounted and secured conduit. A disconnecting means, such as a locking switch (see following **Figure**), must be provided to allow the machine to be disconnected (isolated) from the power supply when required. This installation must be performed by an electrician in accordance with all applicable electrical codes and ordinances.

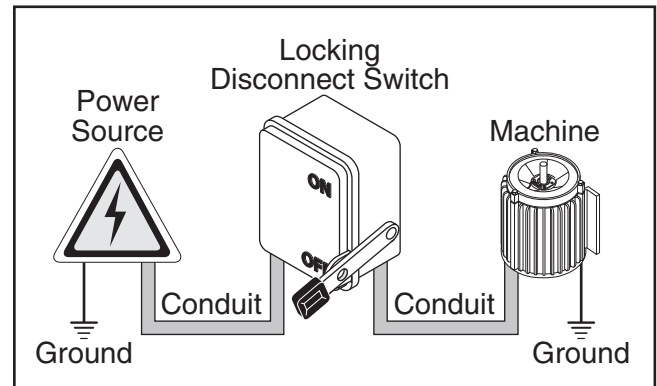

**Figure 1.** Typical setup of a permanently connected machine.

## Grounding Instructions

In the event of a malfunction or breakdown, grounding provides a path of least resistance for electrical current to reduce the risk of electric shock. A permanently connected machine must be connected to a grounded metal permanent wiring system; or to a system having an equipment-grounding conductor. All grounds must be verified and rated for the electrical requirements of the machine. Improper grounding can increase the risk of electric shock!

## **!WARNING**

**Serious injury could occur if you connect the machine to power before completing the setup process. DO NOT connect to power until instructed later in this manual.**

## Extension Cords

Since this machine must be permanently connected to the power supply, an extension cord cannot be used.



## Replaces Page 16

# 460V Conversion

This machine is prewired for 230V 3-phase power but has the capability of operating on 460V power with a minor conversion. The conversion consists of replacing two overload relays and rewiring each of the three motors.

All wiring changes must be inspected by a qualified electrician or service personnel before the machine is connected to the power source. If, at any time during this procedure you need help, call Grizzly Tech Support at (570) 546-9663.

If you do not have three-phase power available for your wide belt sander, you must install a phase converter.

**Note:** When using a phase converter, the power from the manufactured power leg (sometimes called the wild wire) can fluctuate. Connect the manufactured power leg to the S terminal to prevent damage to the transformer. The wire from the S terminal can handle some fluctuation because it goes directly to the motor. The power going to the R and T terminals goes to the transformer and must be consistent to prevent damage.

### To wire sander to 460V:

1. DISCONNECT SANDER FROM POWER!
2. Open electrical cabinet located on back of machine.
3. On transformer, remove wire connected to the far right 220V terminal, and re-connect it to 440V terminal, as shown in **Figure 4**.

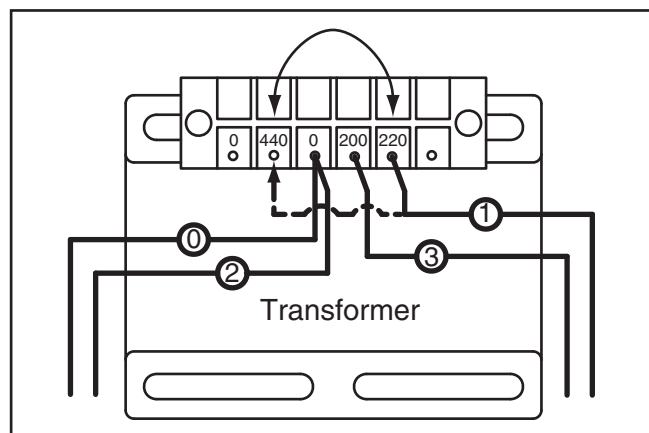

**Figure 4.** 440V transformer connection.

4. Swap out sanding and conveyor motor thermal overload relays with those in 440V conversion kit listed below and at locations shown in **Figure 5**.

**Note:** To order a 440V conversion kit, contact Customer Service at (800) 523-4777.

—For the G9979, order Part Number P99799139A, which includes:

Sanding Motor Overload Relay LR3D21  
(Set amperage dial to 17A)

Conveyor Motor Overload Relay LR3D08  
(Set amperage dial to 3A)

—For the G9980, order Part Number P99809139AV2, which includes:

Sanding Motor Overload Relay LR3D325  
(Set amperage dial to 18A)

Conveyor Motor Overload Relay LR3D08  
(Set amperage dial to 3A)

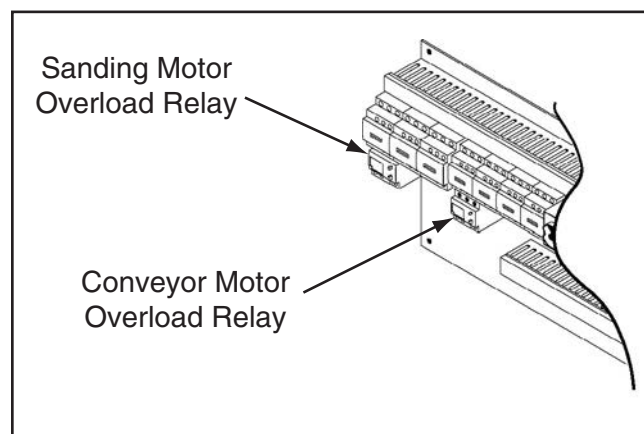

**Figure 5.** Location of 440V conversion components.

5. Wire sanding belt, conveyor belt, and table elevation motors as shown in **Motor Wiring** diagrams on **Page 47** of your owner's manual.



Replaces Page 46

# General Machine Wiring Diagram

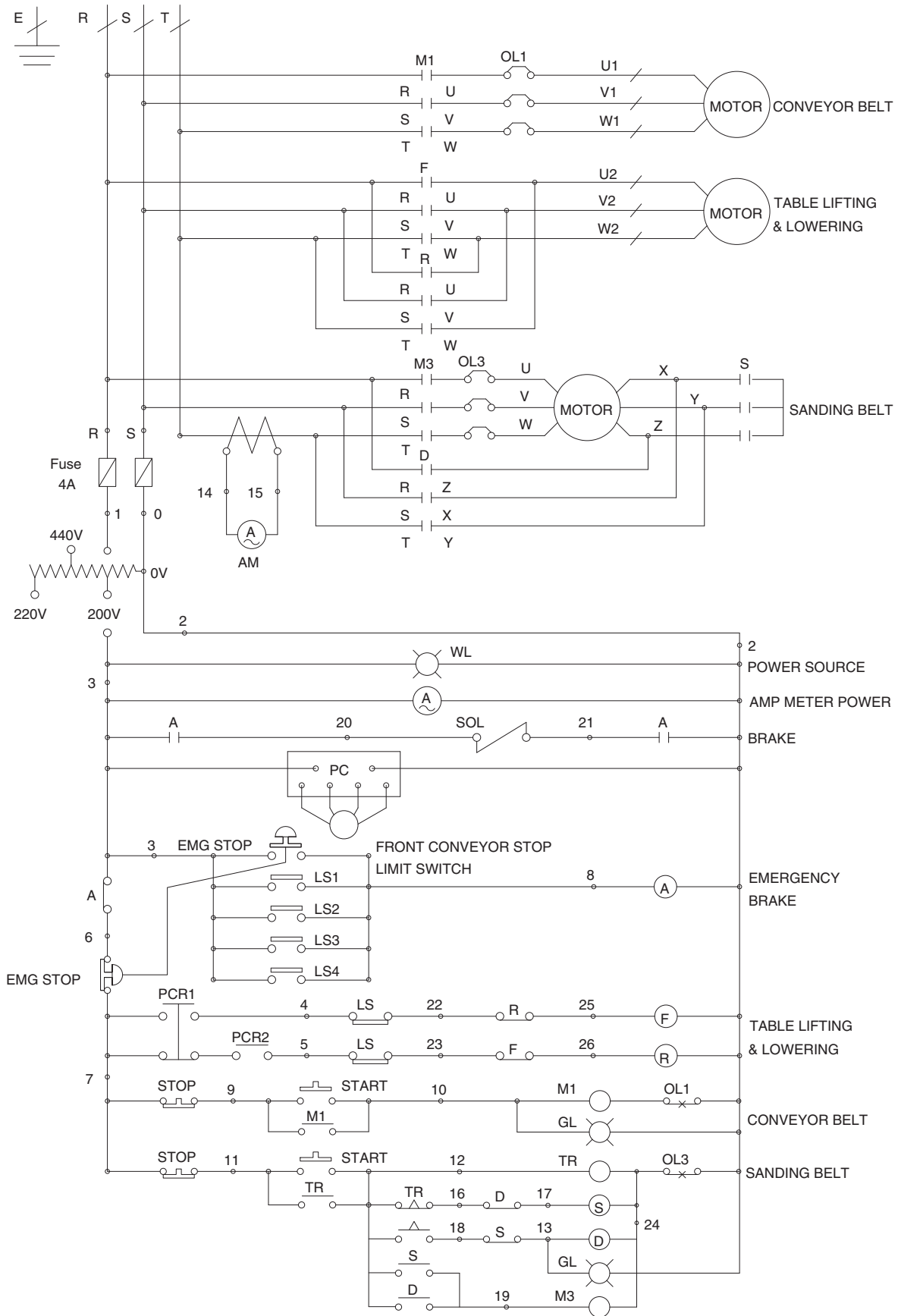

Replaces Page 48

# 220V Electrical Cabinet Wiring Diagram

**NOTICE**  
To rewire for 440V operation, refer to  
440V Conversion on Page 8.

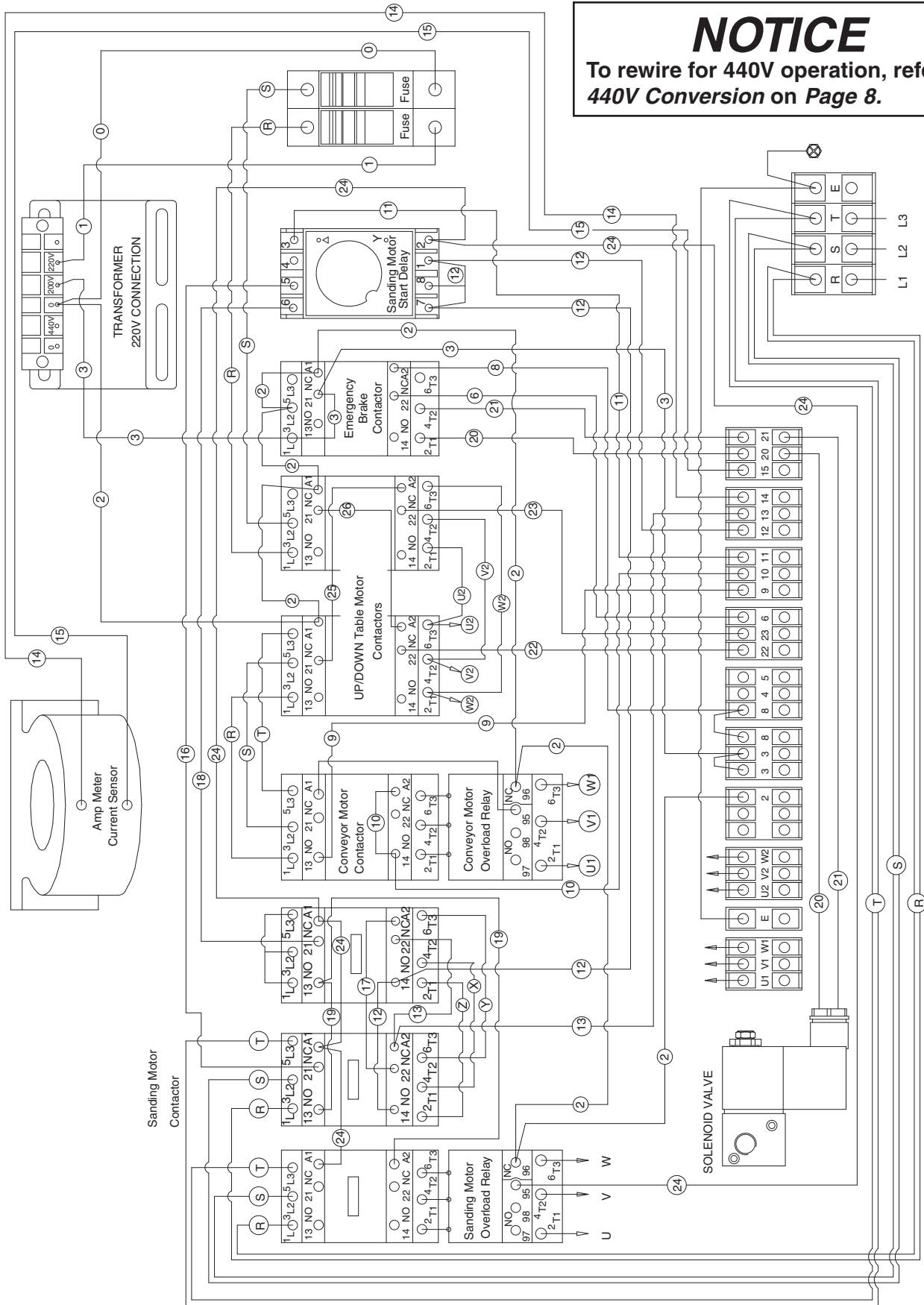

# Changes Pages 66-67

## New Upper Roller Air Cylinder

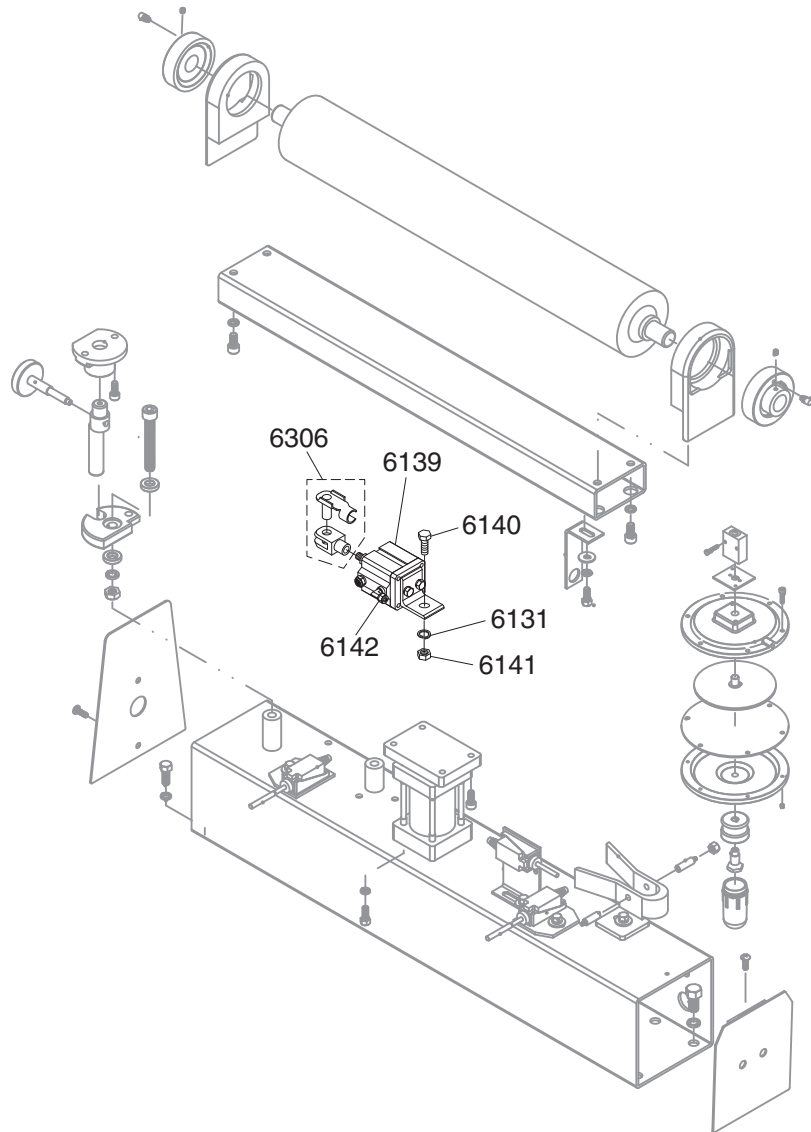

Previous Version Oscillation Diaphragm Assembly

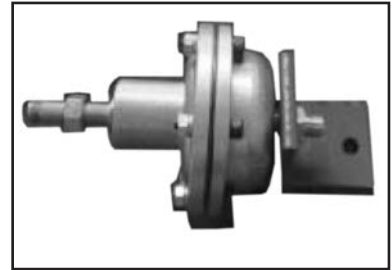

New Version Air Cylinder (Part No 6139)

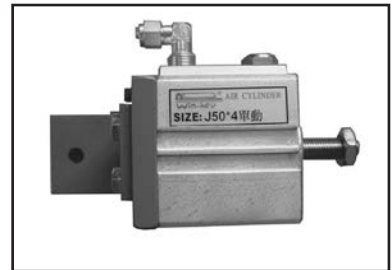

REF	PART #	DESCRIPTION
6131	P99796131	LOCK WASHER 5/16
6139	P99796139	OSCILLATING AIR CYLINDER 50 X 4
6140	P99796140	HEX BOLT 5/16-18 X 1-1/2

REF	PART #	DESCRIPTION
6141	P99796141	HEX NUT 5/16-18
6142	P99796142	CONNECTOR 1/4N X 1/4T X 90DEG
6306	P99796306	UNIVERSAL JOINT FORK



# Replaces Page 72

## Belt Oscillation System Diagram

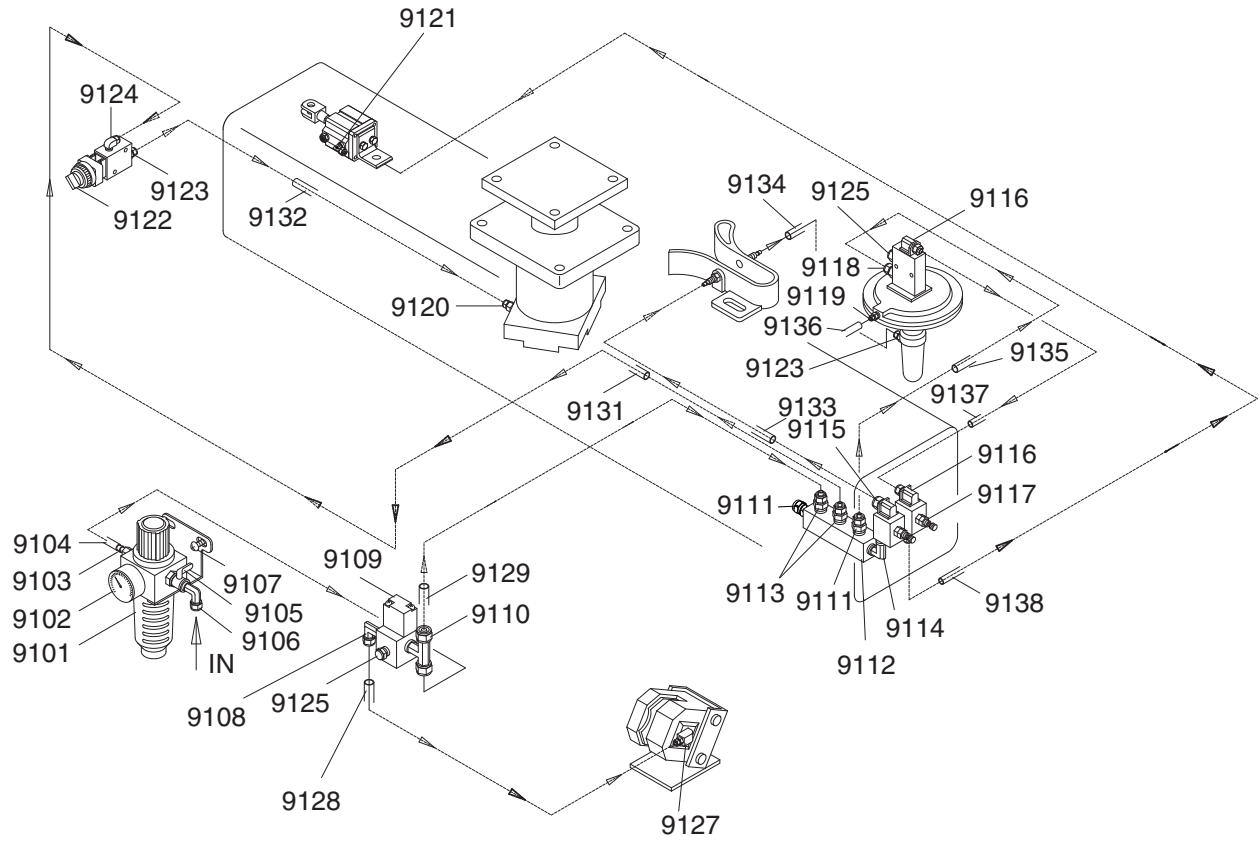

*Replaces Page 73*

# Belt Oscillation System Parts List

9101	P99799101	FILTER CUP
9102	P99799102	PRESSURE REGULATOR
9103	P99799103	BRONZE CONNECTOR
9104	P99799104	FLEXIBLE HOSE
9105	P99799105	AIR SWITCH
9106	P99799106	ELBOW
9107	PS22	PHLP HD SCR 10-24 x 5/8
9108	PH29339108	ELBOW 5/16N X1/8T 90°
9109	P99799109	SOLENOID VALVE
9110	PH29339110	T-FITTING 5/16N X 5/16N X 1/8T
9111	P99799111	CONNECTOR 1/4N X 1/4T
9112	PH29339112	MANIFOLD 1/4N
9113	P99799113	CONNECTOR 5/16N X 1/4T
9114	P99799114	ELBOW 1/4T X 1/8T X 90°
9115	PH29339115	CONNECTOR 1/4N X1/8T 90°
9116	PH29339116	CONNECTOR 1/4N X1/8T 90°
9117	P99799117	THROTTLE VALVE
9118	P99799118	BRASS CONNECTOR

9119	P99799119	CONNECTOR 1/4N
9120	P99799120	CONNECTOR 1/4N X 3/8T
9121	P99799121	CONNECTOR 1/4N X 1/4T X 90°
9122	P99799122	AIR SWITCH
9123	PH29339123	CONNECTOR 1/4N X1/8T
9124	PH29339124	CONNECTOR 1/4N X1/8T 90°
9125	P99799125	BRONZE BUFFER
9127	PH29339127	CONNECTOR 5/16N X 1/8T 90°
9128	P99799128	8MM FLEXIBLE HOSE
9129	P99799129	8MM FLEXIBLE HOSE
9131	P99799131	6MM FLEXIBLE HOSE
9132	P99799132	6MM FLEXIBLE HOSE
9133	P99799133	6MM FLEXIBLE HOSE
9134	P99799134	6MM FLEXIBLE HOSE
9135	P99799135	6MM FLEXIBLE HOSE
9136	P99799136	6MM FLEXIBLE HOSE
9137	P99799137	6MM FLEXIBLE HOSE
9138	P99799138	6MM FLEXIBLE HOSE



***grizzly.com***®  
**TOOL WEBSITE**

Buy Direct and Save with Grizzly® – Trusted, Proven and a Great Value!  
~Since 1983~

*Visit Our Website Today For  
Current Specials!*

**ORDER  
24 HOURS A DAY!  
1-800-523-4777**



# *Grizzly* *Industrial, Inc.*®

## **MODEL G9979/G9980 SUPER INDUSTRIAL-DUTY 43" & 51" WIDE-BELT SANDER INSTRUCTION MANUAL**



COPYRIGHT © NOVEMBER 2005 BY GRIZZLY INDUSTRIAL, INC.  
**WARNING: NO PORTION OF THIS MANUAL MAY BE REPRODUCED IN ANY SHAPE  
OR FORM WITHOUT THE WRITTEN APPROVAL OF GRIZZLY INDUSTRIAL, INC.**  
#CR7364 PRINTED IN TAIWAN

# WARNING

Some dust created by power sanding, sawing, grinding, drilling, and other construction activities contains chemicals known to the State of California to cause cancer, birth defects or other reproductive harm. Some examples of these chemicals are:

- Lead from lead-based paints.
- Crystalline silica from bricks, cement, and other masonry products.
- Arsenic and chromium from chemically treated lumber.

Your risk from these exposures varies, depending on how often you do this type of work. To reduce your exposure to these chemicals: work in a well ventilated area, and work with approved safety equipment, such as those dust masks that are specially designed to filter out microscopic particles.

# Table of Contents

- INTRODUCTION..... 3**
  - Foreword ..... 3
  - Contact Info ..... 3
  - Control Panel Features ..... 4
  - External Features ..... 4
  - Internal Features ..... 5
  - Machine Data Sheet (G9979) ..... 6
  - Machine Data Sheet (G9980) ..... 9
- SECTION 1: SAFETY ..... 12**
  - Safety Instructions for Machinery ..... 12
  - Additional Safety for Wide Belt Sanders ..... 14
- SECTION 2: CIRCUIT REQUIREMENTS ..... 15**
  - 220/440V 3-Phase ..... 15
  - 440V Conversion ..... 16
- SECTION 3: SET UP ..... 17**
  - Unpacking ..... 17
  - Inventory ..... 17
  - Clean Up ..... 18
  - Site Considerations ..... 18
  - Beginning Assembly ..... 19
  - Air Line Installation ..... 19
  - Dust Collection ..... 19
  - Sanding Belt ..... 20
  - Pressure Rollers ..... 21
  - Start Up ..... 21
  - Recommended Adjustments ..... 22
- SECTION 4: OPERATIONS ..... 23**
  - Operation Safety ..... 23
  - Choosing Sandpaper ..... 23
  - Table Movement ..... 24
  - Adjusting Feed Rate ..... 24
  - Amp Draw Meter ..... 25
  - Sanding Workpiece ..... 26
  - Platen Adjustment ..... 26
- SECTION 5: ACCESSORIES ..... 27**
- SECTION 6: MAINTENANCE ..... 28**
  - General ..... 28
  - Schedule ..... 28
  - Sanding Belts ..... 29
  - Air System ..... 29
  - Dust and Water Traps ..... 29



<b>SECTION 7: SERVICE .....</b>	<b>30</b>
Table Calibration .....	30
Platen Service .....	30
Brake Service .....	31
Oscillation Timing .....	32
Oscillation Speed .....	34
Table Parallelism.....	34
Pressure Rollers.....	35
V-Belt Adjustment .....	36
Conveyor Belt Replacement .....	37
Feed Belt Tension .....	39
Feed Belt Tracking .....	39
Air System Diagram .....	40
Troubleshooting.....	41
Notes .....	43
Control Panel Component Locations .....	44
Connection Wiring Diagram 220V/440V 3-Phase .....	45
General Electrical Diagram .....	46
Motor Connections Diagram .....	47
Main Electrical Box Diagram (G9979 220V/440V, G9980 440V) .....	48
Wiring Box Components (G9979 220V/440V, G9980 440V).....	49
Main Electrical Box Diagram (G9980 220V) .....	50
Wiring Box Components (G9980 220V).....	51
<b>SECTION 8: PARTS .....</b>	<b>52</b>
Tool Box and Accessories Diagram.....	52
Tool Box and Accessories Parts List .....	53
Label Diagram.....	54
Labels List.....	55
Sanding Motor System Diagram .....	56
Sanding Motor System Parts List.....	57
Table Lift System Diagram.....	58
Table Lift System Parts List .....	59
Conveyor System Diagram .....	60
Conveyor System Parts List.....	61
Feed, Drum, and Pressure Roller Diagram.....	62
Feed, Drum, and Pressure Roller Parts List .....	63
Sanding Drum and Platen System Diagram .....	64
Sanding Drum, and Platen System Parts List.....	65
Upper Roller System Diagram .....	66
Upper Roller System Parts List.....	67
Cabinet Assembly Diagram.....	68
Cabinet Assembly Parts List .....	69
Main Electrical Panel and Controls Diagram .....	70
Main Electrical Panel and Controls Parts List.....	71
Belt Oscillation System Diagram.....	72
Belt Oscillation System Parts List .....	73
<b>WARRANTY &amp; RETURNS .....</b>	<b>74</b>



# INTRODUCTION

---

---

## Foreword

---

---

We are proud to offer the Model G9979/G9980 Super Industrial-Duty 43" & 51" Wide-Belt Sander. This machine is part of a growing Grizzly family of fine woodworking machinery. When used according to the guidelines set forth in this manual, you can expect years of trouble-free, enjoyable operation and proof of Grizzly's commitment to customer satisfaction.

We are pleased to provide this manual with the Model G9979/G9980 Super Industrial-Duty 43" & 51" Wide-Belt Sander. It was written to guide you through assembly, review safety considerations, and cover general operating procedures.

The specifications, drawings, and photographs illustrated in this manual represent the Model G9979/G9980 Super Industrial-Duty 43" & 51" Wide-Belt Sander as supplied when the manual was prepared. For your convenience, we always keep current Grizzly manuals available on our website at **[www.grizzly.com](http://www.grizzly.com)**. Any updates to your machine will be reflected in these manuals as soon as they are complete.

## Contact Info

---

---

If you have any comments regarding this manual, please write to us at the address below:

Grizzly Industrial, Inc.  
c/o Technical Documentation Manager  
P.O. Box 2069  
Bellingham, WA 98227-2069

We stand behind our machines. If you have any service questions or parts requests, please call or write us at the location listed below.

Grizzly Industrial, Inc.  
1203 Lycoming Mall Circle  
Muncy, PA 17756  
Phone: (570) 546-9663  
Fax: (800) 438-5901  
E-Mail: [techsupport@grizzly.com](mailto:techsupport@grizzly.com)  
Web Site: <http://www.grizzly.com>



# Control Panel Features

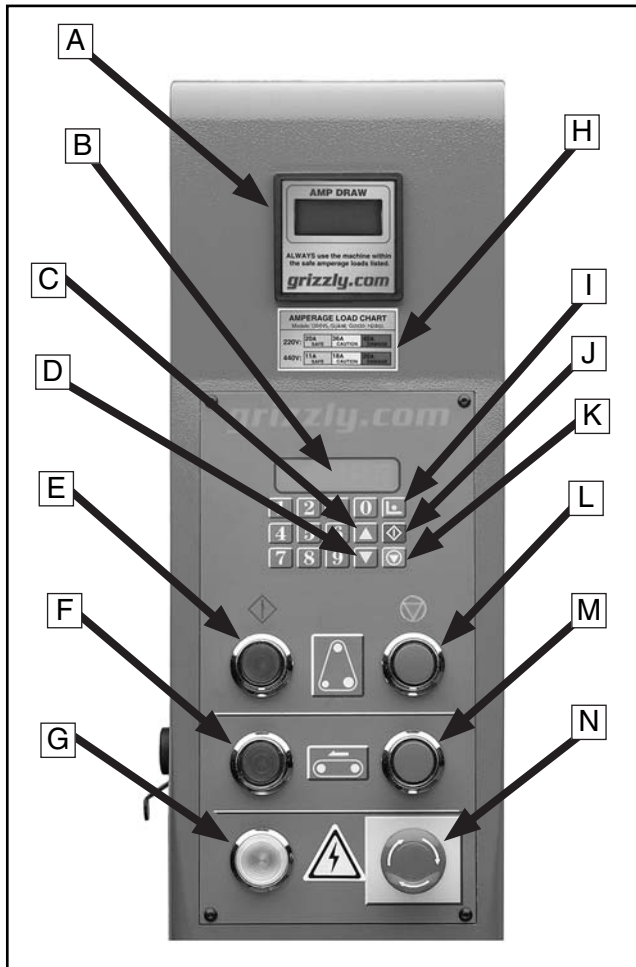

**Figure 1.** Control panel.

- A. Digital Amp Draw Meter
- B. Table-Height Digital Readout
- C. Table Up Key
- D. Table Down Key
- E. Sanding Belt Start Button
- F. Conveyor Belt Start Button
- G. Power Light
- H. Amperage Load Chart
- I. Table Set (Enter) Key
- J. Table Start Key
- K. Table Stop Key
- L. Sanding Belt Stop Button
- M. Feed Belt Stop Button
- N. Emergency Stop Button

# External Features

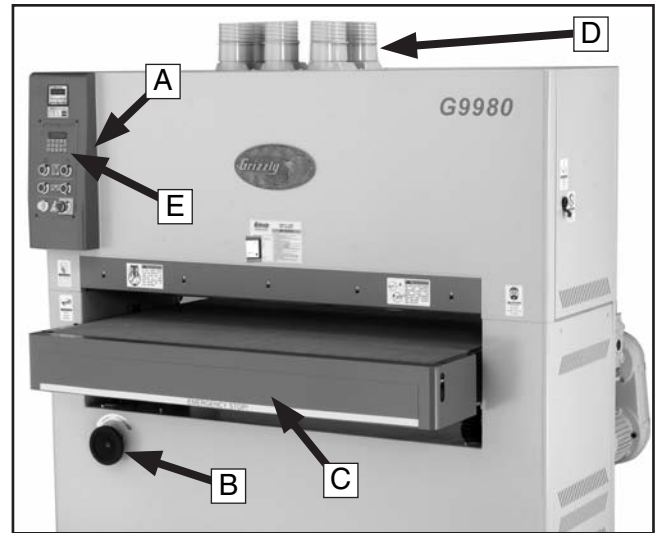

**Figure 2.** Front view.

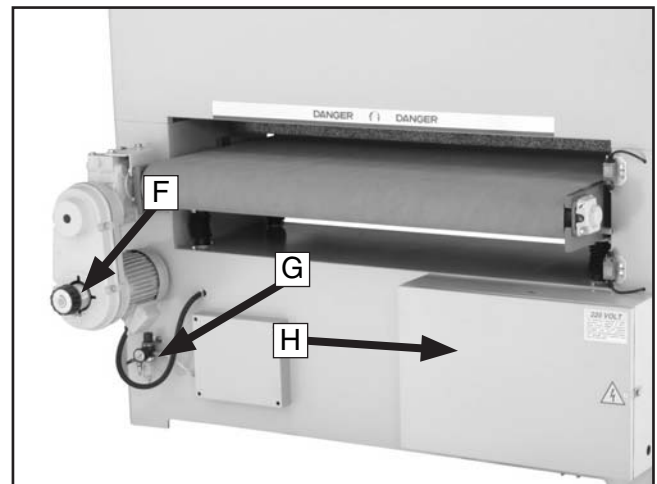
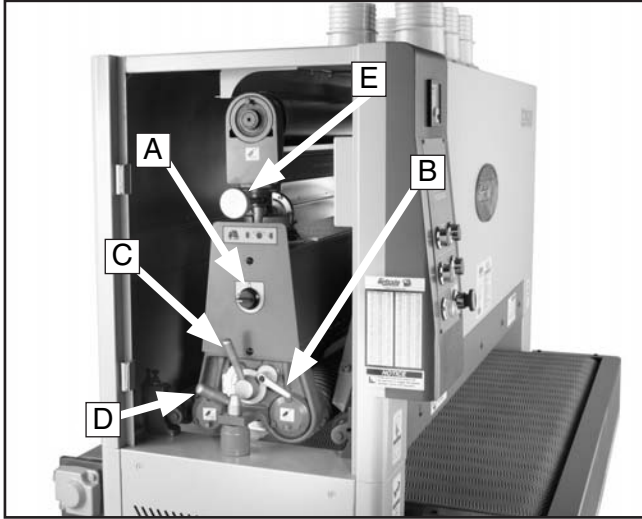

**Figure 3.** Rear view.

- A. Control Panel
- B. Table Height Handwheel
- C. Emergency Stop Push-Panel
- D. Five 4" Dust Collection Ports
- E. Digital Table Height Key Pad
- F. Conveyor Speed Control
- G. Air Pressure Regulator
- H. Main Wiring Box



# Internal Features



**Figure 4.** Inside the left access door.

- A.** Belt Tension Knob
- B.** Platen lock Lever
- C.** Platen Adjustment Lever
- D.** Lock Post Release Lever
- E.** Tracking Adjustment Knob

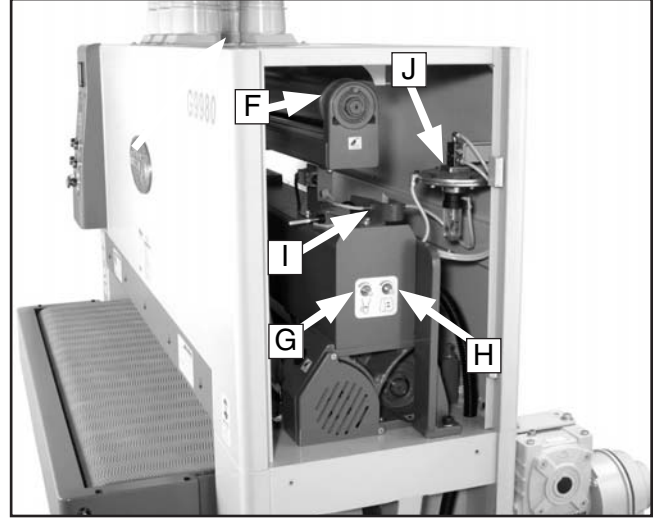

**Figure 5.** Inside the right access door.

- F.** Upper Roller
- G.** Airflow Adjustment Knob
- H.** Speed Control Adjustment Knob
- I.** Air Fork and Air Jet
- J.** Diaphragm Valve Assembly





# MACHINE DATA SHEET

Customer Service #: (570) 546-9663 · To Order Call: (800) 523-4777 · Fax #: (800) 438-5901

## MODEL G9979 43" WIDE-BELT SANDER, 3-PHASE

### Product Dimensions:

Weight..... 2420 lbs.  
Length/Width/Height..... 50 x 62 x 70 in.  
Foot Print (Length/Width)..... 60 x 20-1/2 in.

### Shipping Dimensions:

Type..... Wood Slat Crate  
Content..... Machine  
Weight..... 2490 lbs.  
Length/Width/Height..... 53 x 65 x 72 in.

### Electrical:

Switch..... ON/OFF Emergency Stop  
Switch Voltage..... 200V  
Recommended Breaker Size..... 60 amp  
Plug..... No  
Conversion To 440V..... P99799139  
Phase Converter..... H3741

### Motors:

#### Table Elevation

Type..... TEFC Induction  
Horsepower..... 1/4 HP  
Voltage..... 220/440V  
Prewired..... 220V  
Phase..... Three  
Amps..... 1.2/0.6A  
Speed..... 1725 RPM  
Cycle..... 60 Hz  
Number Of Speeds..... 1  
Power Transfer ..... V-Belt Drive  
Bearings..... Sealed and Lubricated

#### Sanding

Type..... TEFC Induction  
Horsepower..... 25 HP  
Voltage..... 220/440V  
Prewired..... 220V  
Phase..... Three  
Amps..... 64/32A  
Speed..... 1725 RPM  
Cycle..... 60 Hz  
Number Of Speeds..... 1  
Power Transfer ..... V-Belt Drive  
Bearings..... Sealed and Lubricated



## Conveyor

Type.....	TEFC Induction
Horsepower.....	2 HP
Voltage.....	220/440V
Prewired.....	220V
Phase.....	Three
Amps.....	6/3A
Speed.....	1725 RPM
Cycle.....	60 Hz
Number Of Speeds.....	Adjustable
Power Transfer .....	V-Belt Drive
Bearings.....	Sealed and Lubricated

## Main Specifications:

### Operation Information

No Of Sanding Drums.....	1
Maximum Board Width.....	43 in.
Minimum Board Width.....	2 in.
Maximum Board Thickness.....	6 in.
Minimum Board Thickness.....	3/16 in.
Minimum Board Length.....	14 in.
Sanding Belt Speed.....	2200 FPM
Sanding Drums Speed.....	2200 FPM
Conveyor Feed Rate.....	14 - 60 FPM
Sanding Belt Length.....	60 in.
Sanding Belt Width.....	43 in.

### Drum Information

Infeed Sanding Drum Type.....	Spiral Grooved Rubber
Infeed Sanding Drum Size.....	4 in.
Outfeed Sanding Drum Type.....	Steel
Outfeed Sanding Drum Size.....	3-1/2 in.

### Platen Information

Platen Type.....	Felt
Platen Length.....	44-1/2 in.
Platen Width.....	3-1/2 in.

### Construction

Conveyor Belt Construction.....	Rubber
Body Construction.....	Steel
Base Construction.....	Steel
Paint.....	Epoxy

### Other Related Information

Floor To Belt Height.....	34 in.
Belt Tracking.....	Pneumatic
Sanding Belt Tension.....	Pneumatic
No Of Pressure Rollers.....	2
Pressure Roller Type.....	Rubber
Pressure Roller Size.....	2 in.
Conveyor Belt Length.....	78.75 in.
Conveyor Belt Width.....	43 in.
Belt Roller Size.....	4 in.
No Of Dust Ports.....	5
Dust Port Size.....	4 in.
Air Requirement.....	75 PSI



**Other Specifications:**

ISO Factory ..... ISO 9001  
Country Of Origin ..... Taiwan  
Warranty ..... 1 Year  
Serial Number Location ..... ID Label Below Grizzly Nameplate  
Assembly Time ..... 20 minutes

**Features:**

- Variable Feed Speeds
- Independent Motor Control
- Disc Brake Emergency Stop
- Pneumatic Belt Tracking
- Digital Amp/Load Meter
- Digital Keypad Controlled Table Elevation





# MACHINE DATA SHEET

Customer Service #: (570) 546-9663 · To Order Call: (800) 523-4777 · Fax #: (800) 438-5901

## MODEL G9980 51" WIDE-BELT SANDER, 3-PHASE

### Product Dimensions:

Weight..... 2866 lbs.  
 Length/Width/Height..... 50-1/2 x 69 x 70 in.  
 Foot Print (Length/Width)..... 68 x 20-1/2 in.

### Shipping Dimensions:

Type..... Wood Slat Crate  
 Content..... Machine  
 Weight..... 2731 lbs.  
 Length/Width/Height..... 52 x 73 x 74 in.

### Electrical:

Switch..... ON/OFF Emergency Stop  
 Switch Voltage..... 200V  
 Recommended Breaker Size..... 70 amp  
 Plug..... No  
 Conversion To 440V..... P99809139  
 Phase Converter..... H3742

### Motors:

#### Table Elevation

Type..... TEFC Induction  
 Horsepower..... 1/4 HP  
 Voltage..... 220/440V  
 Prewired..... 220V  
 Phase..... Three  
 Amps..... 1.2/0.6A  
 Speed..... 1725 RPM  
 Cycle..... 60 Hz  
 Number Of Speeds..... 1  
 Power Transfer ..... V-Belt Drive  
 Bearings..... Sealed and Lubricated

#### Sanding

Type..... TEFC Induction  
 Horsepower..... 30 HP  
 Voltage..... 220/440V  
 Prewired..... 220V  
 Phase..... Three  
 Amps..... 72/36A  
 Speed..... 1725 RPM  
 Cycle..... 60 Hz  
 Number Of Speeds..... 1  
 Power Transfer ..... Triple V-Belt Drive  
 Bearings..... Sealed and Lubricated



**Conveyor**

Type.....	TEFC Induction
Horsepower.....	2 HP
Voltage.....	220/440V
Prewired.....	220V
Phase.....	Three
Amps.....	6/3A
Speed.....	1725 RPM
Cycle.....	60 Hz
Number Of Speeds.....	Adjustable
Power Transfer .....	V-Belt to Gearbox
Bearings.....	Sealed and Lubricated

**Main Specifications:**

**Operation Information**

No Of Sanding Drums.....	1
Maximum Board Width.....	51 in.
Minimum Board Width.....	2 in.
Maximum Board Thickness.....	6 in.
Minimum Board Thickness.....	3/16 in.
Minimum Board Length.....	14 in.
Sanding Belt Speed.....	2200 FPM
Sanding Drums Speed.....	2200 FPM
Conveyor Feed Rate.....	14 - 60 FPM
Sanding Belt Length.....	60 in.
Sanding Belt Width.....	51 in.

**Drum Information**

Infeed Sanding Drum Type.....	Spiral Grooved Rubber
Infeed Sanding Drum Size.....	4 in.
Outfeed Sanding Drum Type.....	Steel
Outfeed Sanding Drum Size.....	3-1/2 in.

**Platen Information**

Platen Type.....	Felt
Platen Length.....	53-1/2 in.
Platen Width.....	3-1/2 in.

**Construction**

Conveyor Belt Construction.....	Rubber
Body Construction.....	Steel
Base Construction.....	Steel
Paint.....	Epoxy

**Other Related Information**

Floor To Belt Height.....	34 in.
Belt Tracking.....	Pneumatic
Sanding Belt Tension.....	Pneumatic
No Of Pressure Rollers.....	2
Pressure Roller Type.....	Rubber
Pressure Roller Size.....	2 in.
Conveyor Belt Length.....	78.75 in.
Conveyor Belt Width.....	51 in.
Belt Roller Size.....	4 in.
No Of Dust Ports.....	5
Dust Port Size.....	4 in.
Air Requirement.....	75 PSI



**Other Specifications:**

ISO Factory ..... ISO 9001  
Country Of Origin ..... Taiwan  
Warranty ..... 1 Year  
Serial Number Location ..... ID Label Below Grizzly Nameplate  
Assembly Time ..... 20 minutes

**Features:**

- Pneumatic Belt Tensioning
- Pneumatic Belt Tracking
- Independent Motor Control
- Safety Shut-Off Bar
- Disc Brake Emergency Stop
- Digital Amp/Load Meter
- Digital Keypad Controlled Table Elevation
- Micro Adjustable Platen (Rear Head)
- Four Leadscrew Table Lifting and Lowering System



# SECTION 1: SAFETY

## WARNING

### For Your Own Safety, Read Instruction Manual Before Operating this Machine

The purpose of safety symbols is to attract your attention to possible hazardous conditions. This manual uses a series of symbols and signal words which are intended to convey the level of importance of the safety messages. The progression of symbols is described below. Remember that safety messages by themselves do not eliminate danger and are not a substitute for proper accident prevention measures.

 **DANGER** Indicates an imminently hazardous situation which, if not avoided, WILL result in death or serious injury.

 **WARNING** Indicates a potentially hazardous situation which, if not avoided, COULD result in death or serious injury.

 **CAUTION** Indicates a potentially hazardous situation which, if not avoided, MAY result in minor or moderate injury. It may also be used to alert against unsafe practices.

**NOTICE** This symbol is used to alert the user to useful information about proper operation of the machine.

## WARNING

### Safety Instructions for Machinery

- 1. READ THROUGH THE ENTIRE MANUAL BEFORE STARTING MACHINERY.** Machinery presents serious injury hazards to untrained users.
- 2. ALWAYS USE ANSI APPROVED SAFETY GLASSES WHEN OPERATING MACHINERY.** Everyday eyeglasses only have impact resistant lenses. They are NOT safety glasses.
- 3. ALWAYS WEAR AN ANSI APPROVED RESPIRATOR WHEN OPERATING MACHINERY THAT PRODUCES DUST.** Wood dust is a carcinogen and can cause cancer and severe respiratory illnesses.
- 4. ALWAYS USE HEARING PROTECTION WHEN OPERATING MACHINERY.** Machinery noise can cause permanent hearing damage.
- 5. WEAR PROPER APPAREL. DO NOT** wear loose clothing, gloves, neckties, rings, or jewelry which may get caught in moving parts. Wear protective hair covering to contain long hair and wear non-pad footwear.
- 6. NEVER OPERATE MACHINERY WHEN TIRED, OR UNDER THE INFLUENCE OF DRUGS OR ALCOHOL.** Be mentally alert at all times when running machinery.



# WARNING

## Safety Instructions for Machinery

7. **ONLY ALLOW TRAINED AND PROPERLY SUPERVISED PERSONNEL TO OPERATE MACHINERY.** Make sure operation instructions are safe and clearly understood.
8. **KEEP CHILDREN AND VISITORS AWAY.** Keep all children and visitors a safe distance from the work area.
9. **MAKE WORKSHOP CHILD PROOF.** Use padlocks, master switches, and remove start switch keys.
10. **NEVER LEAVE WHEN MACHINE IS RUNNING.** Turn power **OFF** and allow all moving parts to come to a complete stop before leaving machine unattended.
11. **DO NOT USE IN DANGEROUS ENVIRONMENTS.** DO NOT use machinery in damp, wet locations, or where any flammable or noxious fumes may exist.
12. **KEEP WORK AREA CLEAN AND WELL LIT.** Clutter and dark shadows may cause accidents.
13. **USE A GROUNDED EXTENSION CORD RATED FOR THE MACHINE AMPERAGE.** Undersized cords overheat and lose power. Replace extension cords if they become damaged. DO NOT use extension cords for 220V machinery.
14. **ALWAYS DISCONNECT FROM POWER SOURCE BEFORE SERVICING MACHINERY.** Make sure switch is in OFF position before reconnecting.
15. **MAINTAIN MACHINERY WITH CARE.** Keep blades sharp and clean for best and safest performance. Follow instructions for lubricating and changing accessories.
16. **MAKE SURE GUARDS ARE IN PLACE AND WORK CORRECTLY BEFORE USING MACHINERY.**
17. **REMOVE ADJUSTING KEYS AND WRENCHES.** Make a habit of checking for keys and adjusting wrenches before turning machinery **ON**.
18. **CHECK FOR DAMAGED PARTS BEFORE USING MACHINERY.** Check for binding and alignment of parts, broken parts, part mounting, loose bolts, and any other conditions that may affect machine operation. Repair or replace damaged parts.
19. **USE RECOMMENDED ACCESSORIES.** Refer to the instruction manual for recommended accessories. The use of improper accessories may cause risk of injury.
20. **DO NOT FORCE MACHINERY.** Work at the speed for which the machine or accessory was designed.
21. **DO NOT OVERREACH.** Keep proper footing and balance at all times.
22. **MANY MACHINES WILL EJECT THE WORKPIECE TOWARD THE OPERATOR.** Know and avoid conditions that cause the workpiece to "kickback."
23. **ALWAYS LOCK MOBILE BASES (IF USED) BEFORE OPERATING MACHINERY.**
24. **BE AWARE THAT CERTAIN WOODS MAY CAUSE AN ALLERGIC REACTION** in people and animals, especially when exposed to fine dust. Make sure you know what type of wood dust you will be exposed to and always wear an approved respirator.



## **WARNING**

# Additional Safety for Wide Belt Sanders

- 1. INFEEED/OUTFEED AREA.** When feeding the workpiece into the machine, keep clear of kickback path.
- 2. WORKPIECE FEEDING.** Never force the workpiece into the sander, and feed only one workpiece at a time.
- 3. CLOTHING.** Roll up or button sleeves, tie all loose clothing or hair so it will keep clear of entanglement hazards.
- 4. NARROW WORKPIECES.** Never sand workpieces narrower than  $\frac{1}{8}$ ".
- 5. THIN WORKPIECES.** Never sand workpieces thinner than  $\frac{1}{8}$ ".
- 6. SHORT WORKPIECES.** Never sand workpieces shorter than 14".
- 7. HANDS.** Never place hands near, or in contact with, sanding drums or conveyor belt during operation.
- 8. MAINTENANCE.** Perform machine inspections and maintenance service at the appropriate time intervals.
- 9. POWER AND AIR DISCONNECT.** Unless specifically stated in the manual, always disconnect the power source and air from the machine when performing maintenance, adjustments, or assembly. Always read and follow specific safety instructions for each section.
- 10. UNATTENDED MACHINE.** Never leave the machine running unattended.
- 11. SANDPAPER.** Replace sanding belt when it becomes worn or damaged.
- 12. FOREIGN MATERIAL.** Always inspect workpiece for nails, staples, knots, and other imperfections that could be dislodged and thrown from the machine during sanding operations.
- 13. DUST COLLECTION.** Never operate the sander without an adequate dust collection system in place and running.
- 14. ALLERGIES.** Certain woods may cause an allergic reaction in people and animals, especially when exposed to fine dust. Make sure you know what type of wood dust you will be exposed to and always wear an approved respirator.
- 15. ACCESS DOORS.** Never perform sanding operations when the side access doors are open.
- 16. UNDERSTAND INSTRUCTIONS.** Never allow unsupervised or untrained personnel to operate the machine. Make sure any instructions you give in regards to machine operation are approved, correct, safe, and clearly understood.

## **WARNING**

Unfamiliarity with this manual could result in serious personal injury. Spend a sufficient amount of time becoming familiar with the contents of this manual, including all safety warnings.

## **WARNING**

No list of safety guidelines can be complete. Operating this machinery may require additional safety precautions specific to your shop environment. Failure to use reasonable caution while operating this machine could result in serious personal injury.



# SECTION 2: CIRCUIT REQUIREMENTS

## 220/440V 3-Phase

### **⚠️ WARNING**

**Serious personal injury could occur if you connect your machine to the power source before you have completed the set up process. DO NOT connect the machine to the power source until instructed to do so.**

### Amperage Draw

The following list outlines the electrical phase and voltage required to operate the Model G9979 and G9980 wide belt sander, as well as the recommended circuit breaker size. The G9979 and G9980 are prewired for 220V 3-Phase.

**Note:** If you do not have three-phase power available, you will have to install a phase converter listed below.

### Model G9979 3-Phase

If a Phase Converter is required, use the Grizzly Model H3741.

220V Connection Circuit Breaker..... 60 Amps  
440V Connection Circuit Breaker..... 30 Amps

440V Relay Conversion Kit ..... Part # P9979139

### Model G9980 3-Phase

If a Phase Converter is required, use the Grizzly Model H3742.

220V Connection Circuit Breaker..... 70 Amps

440V Connection Circuit Breaker..... 40 Amps  
440V Relay Conversion Kit .... Part # P99809139

### Circuit Requirements

We recommend connecting this machine to a dedicated circuit with a verified ground, using the circuit breaker size given below. Never replace a circuit breaker with one of higher amperage without consulting a qualified electrician to ensure compliance with wiring codes. **If you are unsure about the wiring codes in your area or you plan to connect your machine to a shared circuit, you may create a fire hazard—consult a qualified electrician to reduce this risk.**

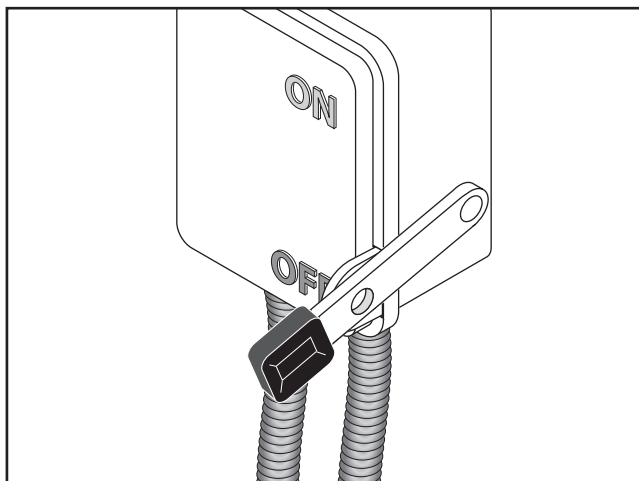

**Figure .** A locking shut-off switch near the machine is preferable to high current plugs.

### **NOTICE**

**The Model G9979/G9980 is prewired for 220V 3-phase operation. If you plan to use your machine with 440V, rewire the machine per the instructions on Page 16, using a qualified electrician!**



# 440V Conversion

To connect this machine to 440V three-phase, you must purchase an overload relay and contactor kit. Each machine requires a unique set. Refer to **440 Conversion Kits** on **Page 71** for the part numbers.

If you do not have three-phase power available for your wide belt sander, you must install a phase converter.

**Note:** When using a phase converter, the power from the manufactured power leg (sometimes called the wild wire) can fluctuate. Connect the manufactured power leg to the S terminal to prevent damage to the transformer. The wire from the S terminal can handle some fluctuation because it goes directly to the motor. The power going to the R and T terminals goes to the transformer and must be consistent to prevent damage.

## To wire the sander to 440V:

1. DISCONNECT THE SANDER FROM THE POWER SOURCE!
2. Open the electrical box located on the back of the machine.
3. On the transformer, remove the wire connected to the 220V terminal for your model of sander, and connect it to the 440V terminal as shown in **Figure 7**.

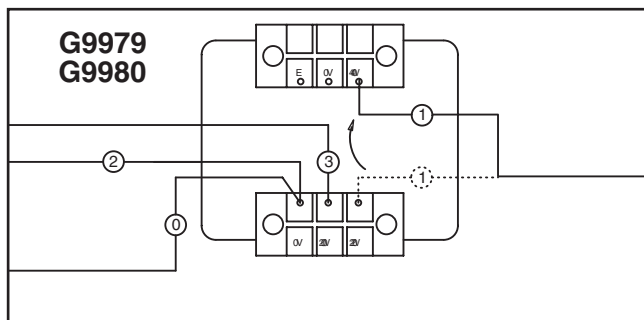
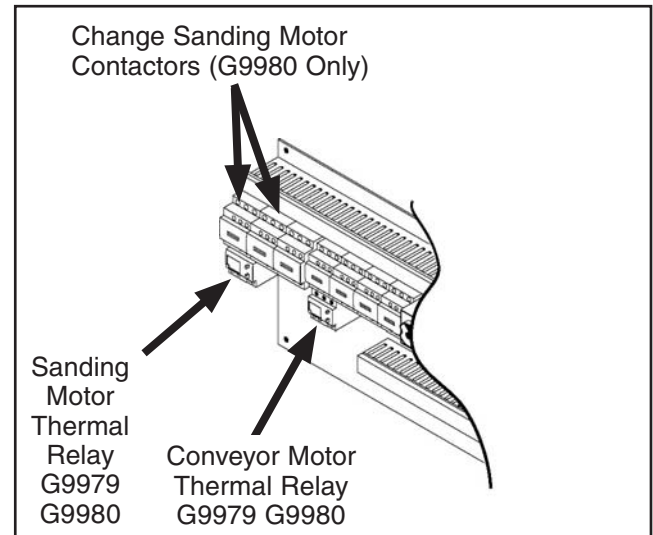

**Figure 7.** 440V transformer connection.

4. Refer to **Figure 8** and find the power panel on your machine.
5. Swap out the applicable thermal relays and contactors from the conversion kit at the locations shown in **Figure 8**.

—For the G9979, use relay kit # P99799139.

—For the G9980, use relay kit # P99809139.



**Figure 8.** Overload relay locations.

6. Wire the sanding belt, conveyor belt, and table elevation motors as shown on the diagrams inside the motor wire covers, or refer to **Motor Wiring** on **Page 47**.



# SECTION 3: SET UP

## Unpacking

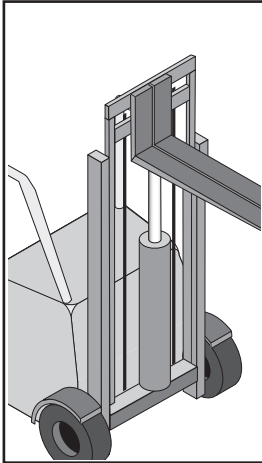

### **⚠️ WARNING**

The Model G9979/G9980 is a heavy machine weighing over one ton. Personal injury can occur if the machine is moved without appropriate machinery. Use a crane or forklift when moving or lifting the machine.

The Model G9979/G9980 was carefully packed when it left our warehouse. If you discover the machine is damaged after you have signed for delivery, please immediately call Customer Service at (570) 546-9663 for advice.

Save the containers and all packing materials for possible inspection by the carrier or its agent. Otherwise, filing a freight claim can be difficult.

When you are completely satisfied with the condition of your shipment, you should inventory the contents.

### **NOTICE**

A parts diagram and parts list are located near the end of the manual. Use the diagram and list to identify missing parts or to supplement the assembly instructions provided in this manual.

## Inventory

Crate contents, see Figure 10.

A.	Sanding Unit (Not Pictured)	1
B.	Dust Ports 4"	5
C.	Sanding Belt 100 Grit	1
D.	Sanding Belt 180 Grit	1
E.	Platen Graphite Flap	2
F.	Platen Felt	1
G.	Tool Box	1
	—Phillips Head Screwdriver #2	1
	—Standard Screwdriver #2	1
	—Open-End Wrench 8/10mm	1
	—Open-End Wrench 12/14mm	1
	—Open-End Wrench 17/19mm	1
	—Metric Hex Wrench Set 10 Pcs.	1
	—Door Keys	2
	—Ceramic Limit Switch Rub Rods	2
	—Flexible Grease Gun Extension	1
	—Platen Removal Tool	1

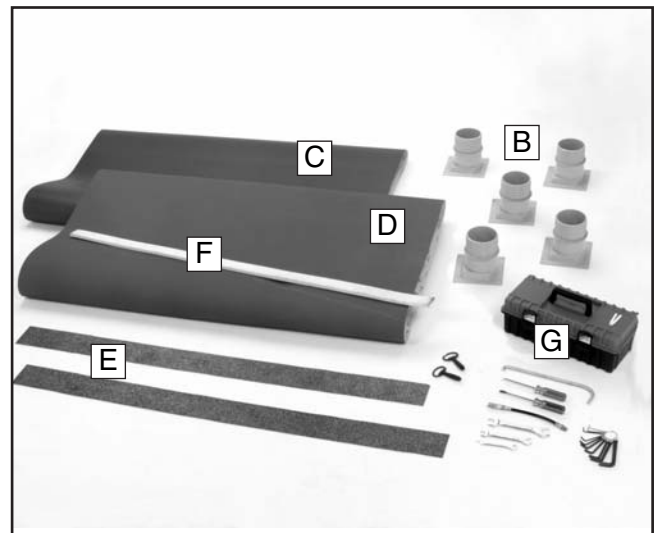



Figure 10. Parts layout.



# Clean Up

The upper drum on this machine is coated with a waxy oil to protect it from corrosion during shipment. Remove this protective coating with a solvent cleaner or citrus-based degreaser such as Grizzly's G7895 Degreaser. To clean thoroughly, some parts may need to be removed. **For optimum performance from your machine, make sure you clean all moving parts or sliding contact surfaces that are coated.** Avoid chlorine-based solvents as they may damage painted surfaces should they come in contact.

	<p><b>!WARNING</b> Gasoline and petroleum products have low flash points and could explode if used to clean machinery. <b>DO NOT</b> use gasoline or petroleum products to clean the machinery.</p>
---	---

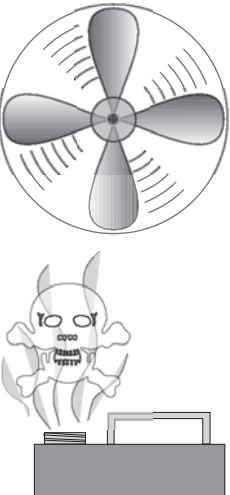
	<p><b>!WARNING</b> Lack of ventilation while using solvents could cause serious personal health risks, fire, or environmental hazards. Always work in a well ventilated area to prevent the accumulation of dangerous fumes. Supply the work area with a constant source of fresh air.</p>
---	--

# Site Considerations

## Floor Load

Refer to the **Machine Data Sheet** for the weight and footprint specifications of your machine. Some shop floors may require additional reinforcement to support both the machine and operator.

## Working Clearance

Working clearances can be thought of as the distances between machines and obstacles that allow safe operation of every machine without limitation. Refer to the Machine Data Sheet for dimensions of your machine. Consider existing and anticipated machine needs, size of material to be processed through each machine, and space for auxiliary stands and/or work tables. Also, consider the relative position of each machine to one another for efficient material handling. Be sure to allow yourself sufficient room to safely run your machines in any foreseeable operation and keep dust collection hoses off the floor and out of the way.

## Lighting

Lighting should be bright enough to eliminate shadows and prevent eye strain. Electrical circuits should be dedicated or large enough to handle combined motor amp loads. Be sure to observe local electrical codes for proper installation of new lighting or circuits.

	<p><b>!WARNING</b> Unsupervised children and visitors entering a shop could suffer serious personal injury. Ensure child and visitor safety by keeping all entrances to the shop locked at all times. <b>DO NOT</b> allow unsupervised children or visitors in the shop at any time.</p>
--	--



# Beginning Assembly

Complete the assembly in the order provided in this manual, then read the rest of the manual before attempting any type of sanding operation. **Your safety is important! Please follow the warnings below during this entire section:**

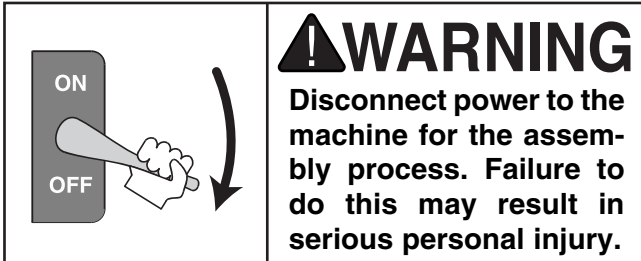

## Air Line Installation

To install the air line:

1. Connect the hose from your air compressor to the air inlet (**Figure 9**) on the regulator.

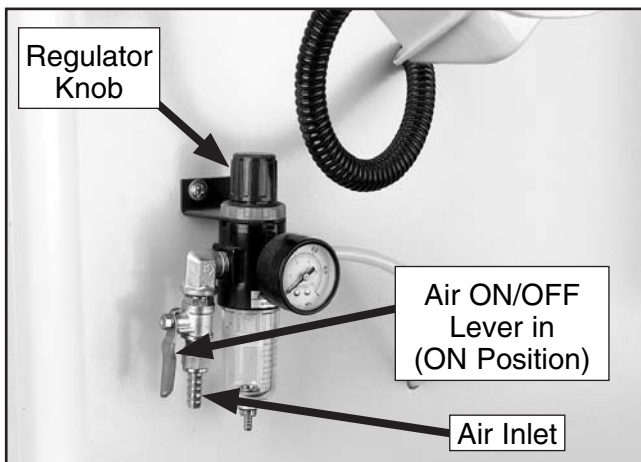
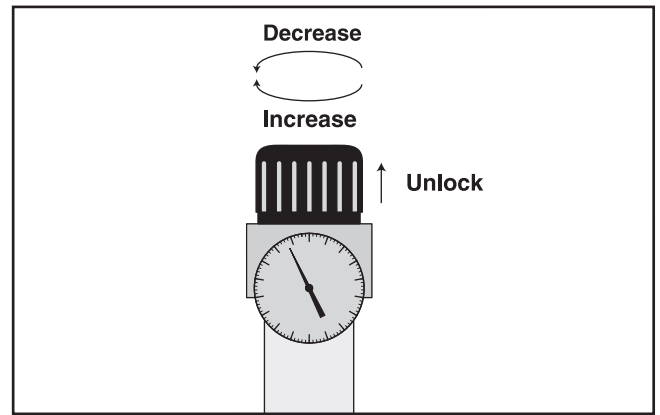

**Figure 9.** Air inlet located on regulator.

2. Make sure the red handle on the regulator is in the **ON** position.
3. Lift the regulator knob (**Figures 9 & 10**) and turn it until the gauge reads 75 PSI.

**Note:** Turn the knob clockwise to increase the air pressure and counterclockwise to lower the air pressure.

4. Push the regulator knob down until it snaps.



**Figure 10.** Regulator knob.

## Dust Collection

**Recommended CFM at Dust Ports: 2000 CFM**  
Do not confuse this CFM recommendation with the rating of the dust collector. To determine the CFM at the dust port, you must take into account many variables, including the CFM rating of the dust collector, the length of hose between the dust collector and the machine, the amount of branches or wyes, and the amount of other open lines throughout the system. Explaining this calculation is beyond the scope of this manual. If you are unsure of your system, consult an expert or purchase a good dust collection "how-to" book.

To hook up a dust collection system:

1. Install the dust ports (**Figure 11**) to the mounting locations on the top of the sanding unit with the supplied M6-1 x 10 Phillips head screws.



**Figure 11.** Typical dust port configuration.

2. Using 4" hose clamps, secure the hoses from your dust collection system to the dust ports.



# Sanding Belt

## To install the sanding belt:

1. DISCONNECT THE SANDER FROM THE POWER SOURCE!
2. De-activate the belt tension piston by turning the belt tension knob (**Figure 12**).
3. Remove the lock post release lever (**Figure 12**) by turning it counterclockwise  $\frac{1}{2}$  turn and pulling it up and out of the mounting hole.
4. Remove the spacer block (**Figure 12**).

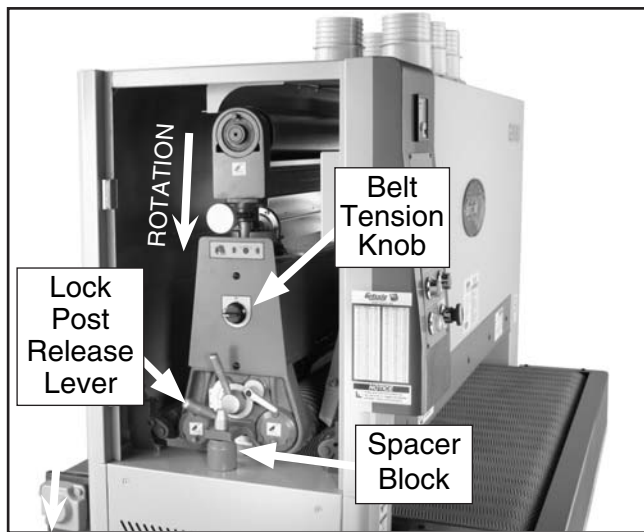

**Figure 12.** Components used when changing a sanding belt.

5. Making sure the rotation arrows on the sanding belt point the same direction as those shown in **Figure 12**, install the sanding belt by starting first on the upper roller and then the lower roller.

**Note:** The sanding belt must be centered between the limit switches and the edge of the sanding belt must be between tongs of the oscillation controller as shown in **Figure 13**. Damage to the sanding belt could occur if the sander is turned **ON** before the sanding belt is correctly positioned.

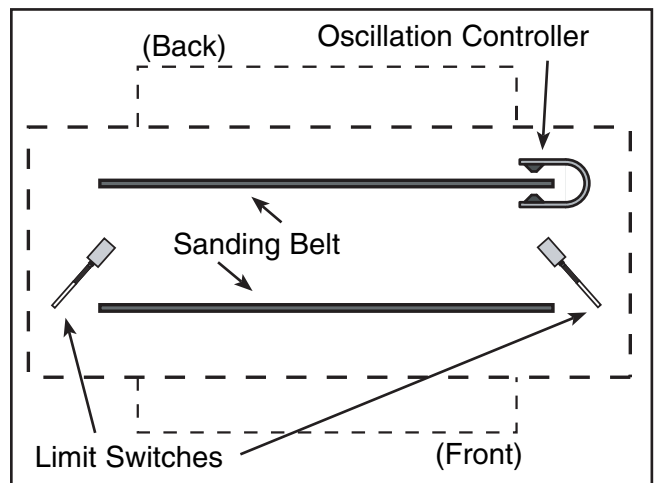

**Figure 13.** Sander Outline (Top View). Proper position of belt between the limit switches.

## NOTICE

The directional arrow on the back of the sanding belt must be pointing in a counterclockwise direction during installation. Failure to install the sanding belt correctly could result in damage to the sanding belt or the sander itself.

6. Replace the spacer block and tighten down the lock handle bolt.
7. With your hands clear of all moving parts, tension the belt by turning the belt tension knob.



# Pressure Rollers

The pressure rollers have been set at the factory, but for safety, you should verify that they are set below the level of the sanding roller.

## WARNING

It is absolutely essential to keep the pressure rollers set below the level of the sanding roller. If the pressure rollers are even, or higher than the sanding roller, the wood **WILL** be propelled from the sander at a high rate of speed. This situation could cause serious kick-back injury.

### To check the pressure roller height:

1. DISCONNECT THE SANDER FROM THE POWER SOURCE!
2. Place a piece of scrap wood of uniform thickness across the table so it spans both the front and the rear pressure rollers at the same time.
3. With the air pressure connected and the sanding belt installed and tensioned, manually raise the table and verify that the board touches both pressure rollers before it touches the sanding belt.

**Note:** If the board does not touch both pressure rollers before it touches the sanding belt, then the pressure rollers must be adjusted before operation. See **Pressure Rollers** on **Page 35** for step-by-step instructions.

# Start Up

## WARNING

Serious personal injury could result if the machine is connected to the power source during assembly or adjustment. Wait until the machine is turned OFF, unplugged, and all working parts have come to a complete stop before you attempt to assemble or adjust the machine!

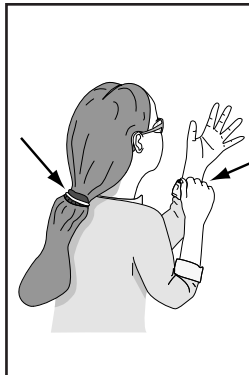

## WARNING

Loose hair and clothing could get caught in machinery causing serious personal injury. Keep loose clothing rolled up and long hair tied up and away from machinery.

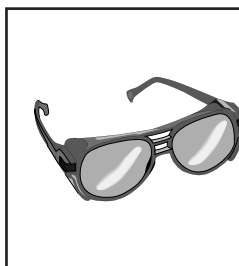

## WARNING

Projectiles thrown from the machine could cause serious eye injury. Wear safety glasses during start up.

### Before starting the machine:

1. Read this manual and make sure you take all safety precautions before operating this machine.
2. Make sure all the wiring is correct.
3. Make sure the machine is connected to an air compressor and the pressure gauge reads 75 PSI.
4. Make sure all tools or foreign objects have been removed from the conveyor surface, the top of the machine, and the inside of the machine.



## To start the machine:

1. PUT ON YOUR SAFETY GLASSES AND RESPIRATOR!
2. Connect the machine to the power source.
3. Press the TABLE UP and TABLE DOWN keys. The table should go up and down smoothly.

**Note:** Make sure the table moves in the same direction as the button description. If not, then the power needs to be disconnected and any two power wires need to be switched at the circuit breaker in the electrical box. If using a phase converter, switch the R and T wires.

4. Press the FEED BELT START and FEED BELT STOP buttons. The feed belt should start, run, and stop smoothly.
5. Press the SANDING BELT START and SANDING BELT STOP buttons. The sanding belt should start, run, and stop smoothly.

The machine should run smoothly, with little or no vibration or rubbing noises. Strange or unusual noises should be investigated and corrected before operating the machine further.

If the machine seems to be running correctly, let it run for a short time to ensure that the moving parts are working properly with no excessive vibration. DO NOT operate the machine if problems cannot be corrected.

If you cannot locate the source of unusual noises, refer to **Troubleshooting**, and feel free to contact our Technical Support Department at (570) 546-9663.

# Recommended Adjustments

---

---

For your convenience, the adjustments listed below have been performed at the factory and require no further adjustment. However, we recommend that you verify that the adjustments are correct and to your satisfaction.

## Recommended adjustment checklist:

- Table Calibration, Page 30.
- Feed Belt Tension, Page 39.
- Feed Belt Tracking, Page 39.
- Air Regulator to 75 PSI, Page 19.
- Oscillation Timing, Page 32.
- Oscillation Speed, Page 34.
- Pressure Rollers, Page 35.
- Table Parallelism, Page 34.
- V-Belt Adjustment, Page 36.



# SECTION 4: OPERATIONS

## Operation Safety

Your safety is important! Please follow the warnings below during this entire section:

### **WARNING**

To avoid serious personal injury, read and become familiar with the entire instruction manual before using this wide belt sander.

### **WARNING**

Damage to your eyes, lungs, and ears could result from failure to wear safety glasses, a dust mask, and hearing protection while sanding with this machine.

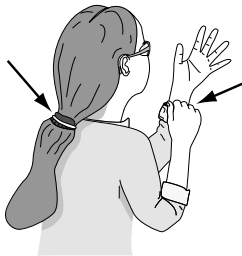

### **WARNING**

Loose hair and clothing could get caught in machinery and cause serious personal injury. Keep loose clothing rolled up and long hair tied up and away from machinery.

## Choosing Sandpaper

The grit you choose will depend on the type of work, the species of wood and the stage of finishing. Below is a chart that groups abrasives into different categories and shows which grits fall into each one. We recommend using aluminum oxide sanding belts for the best results.

Grit	Type
60	Coarse
80-100	Medium
120-150	Fine

The general rule of thumb is to sand a workpiece with progressively higher grit numbers, with no one grit increase of more than 50; however, the type of wood and desired finish will determine the best grit to use.



# Table Movement

Table height can be adjusted manually or with the digital key pad and motor (see **Figure 14**).

**Manual Table Movement:** Turn the handwheel located under the front of the infeed table for manual table positioning.

**Motorized Table Movement:** Press the TABLE UP or TABLE DOWN key once for motorized table positioning in 0.005" (0.1mm increments).

**Numerical Key Pad:** Enters the position of sanding depth.

**Metric or Standard Key:** Press and hold the SET button for 3 seconds to calibrate display at the current board thickness; or press and hold key for 10 seconds to toggle the display between metric and standard measurement.

**Table Start Key:** Moves table to a preset sanding depth.

**Table Stop Key:** Stops table movement immediately.

**Digital Display:** Shows final table sanding depth.

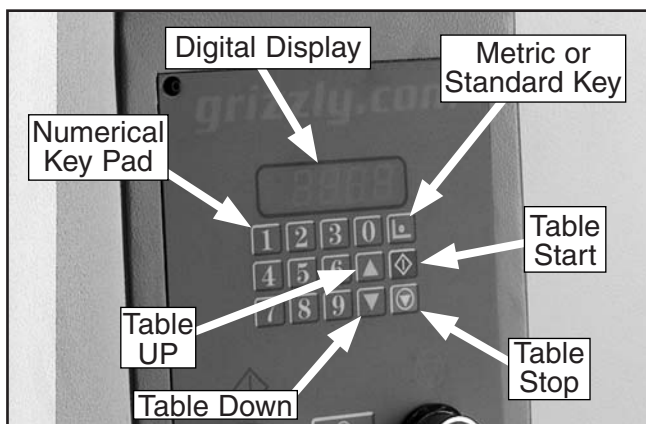

**Figure 14.** Keys for adjusting the table height.

## NOTICE

The thickness gauge is pre-calibrated from the factory; however, correct calibration should be verified.

# Adjusting Feed Rate

The dial attached to the side of the feed belt gear box (**Figure 15**) adjusts the feed rate of the sander.

**Note:** Never adjust the feed rate dial unless the conveyor belt is running; otherwise, you can damage the control.

**Changing Feed Rate:** Turn the dial clockwise to decrease the feed rate and counterclockwise to increase it.

**Determining Ideal Feed Rates:** Softwoods typically require a faster feed rate than hardwoods; however, there is no definitive rule to follow when determining the best feed rate. As a general rule, always start with the slowest feed rate and work your way up. We always recommend testing the feed rate on scrap wood similar to your work-piece. Be sure to monitor the amperage meter when adjusting the feed rate. Decrease the feed rate if the amperage load begins to slow the motor RPM.



**Figure 15.** Feed rate dial.



# Amp Draw Meter

The amperage draw meter (**Figure 16**) is located above the control panel. Use the meter to monitor the amperage draw on the machine while performing sanding operations.

As a general rule, always start with a small load and work your way up. **DO NOT** work your machine to its maximum load, where you can hear the motor lose RPM; instead, make multiple passes or install a coarser grit paper.

Amp load will be directly affected by many factors such as feed rate, depth of cut, wood type, sandpaper grit, and workpiece width. If the amp load is in the red load range, the machine is overloaded and motor damage will occur. Keep the amp load in the green range during operation.

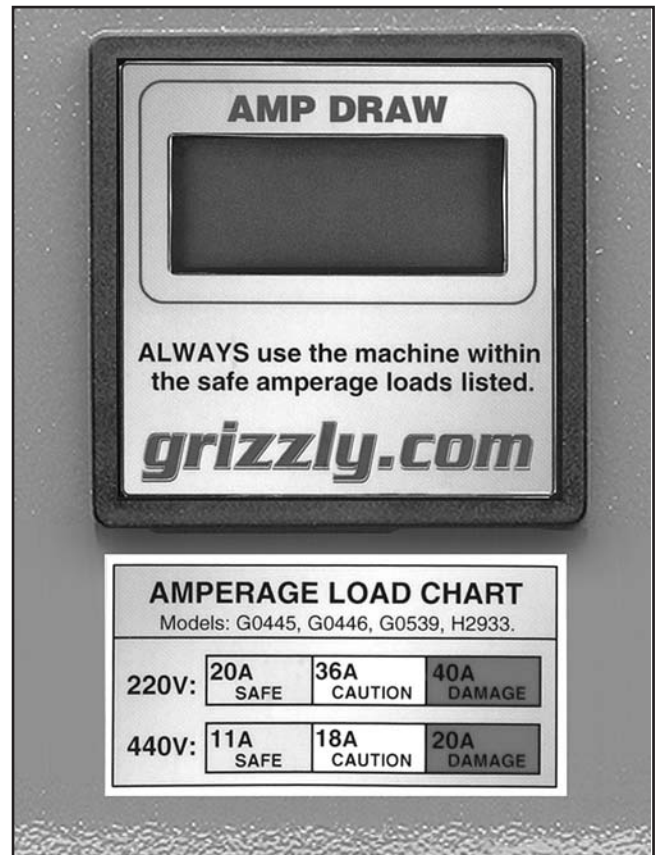

**Figure 16.** Typical amp draw meter and load chart.

## NOTICE

**DO NOT VOID WARRANTY!** Keep the amp draw within the GREEN load range shown on the AMP LOAD CHART. If you operate the sander in the RED load range, capacitor or motor failure will occur and will not be covered under warranty.



# Sanding Workpiece

Typically, no more than 0.5mm (approx.  $\frac{1}{64}$ " ) of material is removed during each pass. Attempts to remove too much material can cause jamming, wood burning, rapid paper wear or tearing, poor finish, short motor life. Make sure to measure the workpiece thickness before and after all sanding passes.

**The following is the correct sanding operating procedure:**

1. PUT ON YOUR SAFETY GLASSES AND A RESPIRATOR!
2. Turn the dust collector **ON**.
3. On the initial pass, set the table to approximately 0.25" greater than the thickness of the workpiece.

**Note:** This initial pass setting reduces the chance of overloading the sander on undetected high points on the workpiece.

4. Continue to raise the table 0.0625" between each successive pass until the sander begins to sand the workpiece.

## NOTICE

**It may be necessary to send wide stock through the sander two or three times between table height adjustments. This reduces the likelihood of burning the wood if there is a high spot.**

# Platen Adjustment

Your sander is equipped with an adjustable felt platen and graphite pad for extra sensitive sanding operations. The platen position allows for three basic types of sanding, which can be adjusted by rotating the height lever shown in **Figure 17**.

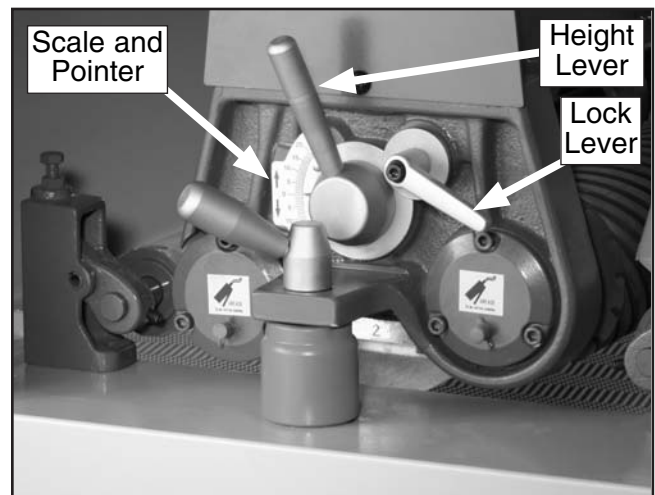

**Figure 17.** Platen height controls.

## To use the platen:

For an initial heavy sanding pass, the platen is raised above the level of the drums, and the table is adjusted to set the sanding depth. The drums do all the work with #100 grit or coarser sandpaper, but you will have a rough finish.

For an intermediate finishing pass, the platen is lowered so it is level with the drums, and the table is adjusted to set sanding depth. The best belt grit for this position is #100 to #180.

For a final sanding pass, do not adjust the table to change the sanding depth. The drums must touch the workpiece without doing any sanding. The platen should be lowered to 0.2 to 0.5 mm below the sanding drums. You can lower the platen up to 2 mm below the drums for short intervals, but streaking, burn marks, and premature graphite/platen wear can occur if this setting is abused. The best belt grit for the final sanding pass is #180 or finer.

**Note:** The platen scale is broken down in arbitrary increments.



# SECTION 5: ACCESSORIES

## Grizzly Rotary Phase Converter

Add 3-phase, multi-motor capability to your single-phase electrical supply. Operate single or multiple motors, transformers, and resistance loads at 100% power and 95% efficiency while saving big dollars at cheaply metered, single-phase electrical rates. Complete step by step instructions are furnished along with complete wire and fusing requirements for various motor loads. Each model operates up to twice its nameplate rating in a mixed-motor load. On heavily loaded or hard-start applications, such as high-speed geared-head lathes and air conditioning compressors, the nameplate rating of the converter you choose should be 2 to 3 times the HP of the most heavily loaded motor. See the individual 3-phase machine pages for phase converter recommendations. For application assistance, please call our technical support at (570) 546-9663.

—For the Model G9979 Wide Belt Sander, use Phase Converter Model H3741.

—For the Model G9980 Wide Belt Sander, use Phase Converter Model H3742.



**Figure 18.** Rotary phase converter.

## H2845 Cleaning Pads

Cleaning pads are the perfect accessory for wide belt sanders. Simply set the conveyor table to height and feed the pad through to “unload” a dirty sanding belt. Regular cleaning greatly increases the lifespan of sanding belts. Check the current Grizzly catalog or [www.grizzly.com](http://www.grizzly.com) for more details.

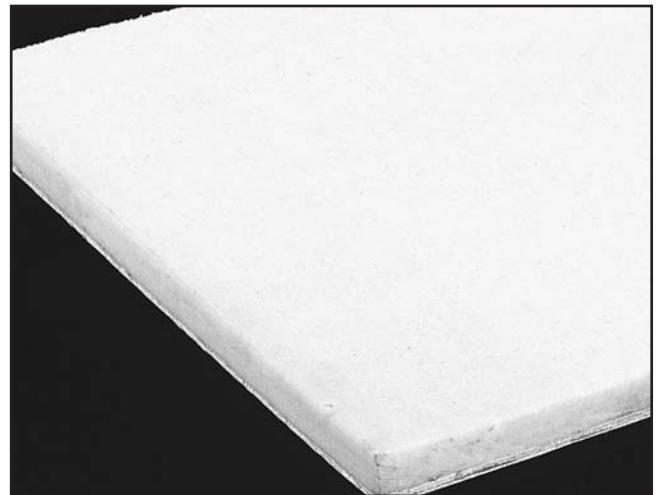

**Figure 19.** Sanding belt cleaning pad.

## Grizzly Aluminium Oxide Sanding Belts for 43" and 51" Wide Belt Sanders

<b>Swiss-Made Sanding Belts for Model G9979 43"W x 60"L:</b>	<b>US-Made Sanding Belts for Model G9979 43"W x 60"L:</b>
—H8769 60 Grit	—H3747 60 Grit
—H8770 80 Grit	—H3748 80 Grit
—H8771 100 Grit	—H3749 100 Grit
—H8772 120 Grit	—H3750 120 Grit
—H8773 150 Grit	—H3751 150 Grit
—H8774 220 Grit	
<b>Swiss-Made Sanding Belts for Model G9980 51"W x 60"L:</b>	<b>US-Made Sanding Belts for Model G9980 51"W x 60"L:</b>
—H8775 60 Grit	—H3752 60 Grit
—H8776 80 Grit	—H3753 80 Grit
—H8777 100 Grit	—H3754 100 Grit
—H8778 120 Grit	—H3755 120 Grit
—H8779 150 Grit	—H3756 150 Grit
—H8780 220 Grit	—H3751 220 Grit



# SECTION 6: MAINTENANCE

## General

Your safety is important! Please follow the warnings below during this entire section:

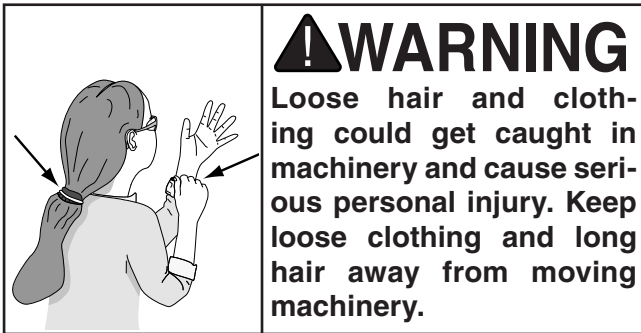
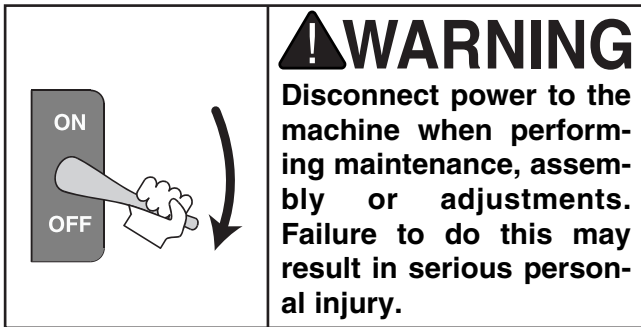

## Schedule

The following items should be checked each time the sander is used:

- Loose mounting bolts.
- Damaged sanding belt.
- Worn or damaged wires.
- Water collection cups filled with water.
- Dust trap filled with sanding dust.
- Emergency stop break system.
- Any other condition that could hamper the safe operation of this machine.

## Weekly

Grease the grease fittings located on the feed belt roller axles and the sanding belt roller axles. They are identified with yellow labels.

## Monthly

Apply a generous amount of grease to the table elevation screws. Be sure to recover the adjustment screws with the dust covers when finished.

Remove the lower side panel to access the table lifting mechanism. Apply grease to the chain and gears associated with the table lifting mechanism. Be careful to not get grease on the V-belts.

## After the First 100 Hours

The oil inside the conveyor gear reducer should be replaced after the first 100 working hours of operation. We recommend 90 Wt. gear oil.

## Every 2500 Hours

After the first conveyor gear reducer oil change, replace the oil after every 2500 working hours of operation. We recommend 90 Wt. gear oil.

## Yearly

Replace the water trap filter.



# Sanding Belts

You can greatly increase the lifespan of your sanding belts if you clean them often. As mentioned on **Page 27**, cleaning pads are the fastest way to remove saw dust build-up.

## Air System

The air system is durable and reliable; however, components do wear with age. If you suspect that a component in your air system may be causing problems, see the air line circuit on **Page 40**.

- Adjust regulator to 75 PSI.
- Carefully inspect all air lines for cracks, tears or hardening. Replace faulty hoses.
- Check the air connections for leaks. A small amount of soapy water in a questionable area will bubble if there is a leak.
- Make sure lines are not clogged. Remove a questionable line and blow through it as a test.

### CAUTION

If a component in the air system is malfunctioning, bleed all air from the system, and fix the problem before you resume sanding.

# Dust and Water Traps

There are two traps on this wide belt sander. One water trap is attached to the bottom of the air regulator, and the other trap is attached on the air diaphragm assembly. Cleaning is easy. With the system under air pressure, push the lower drain valve to empty the regulator water trap (**Figure 20**). Replace the internal white moisture filter yearly. To empty the dust trap bowl, relieve the air pressure and then unscrew and empty the bowl (**Figure 21**). DO NOT allow the water trap or dust bowl to become full.

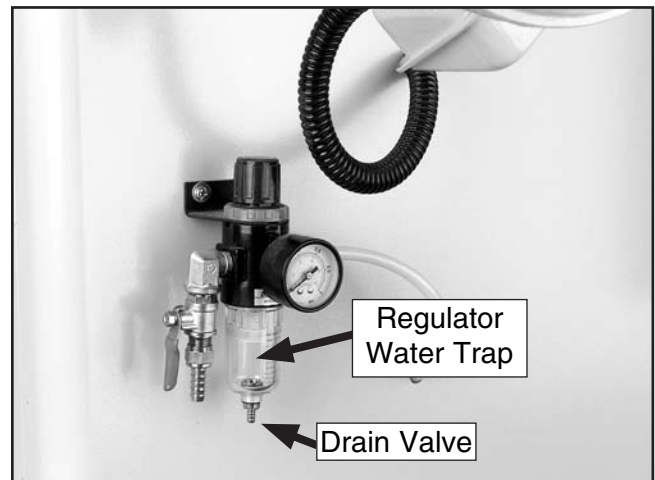

**Figure 20.** Water trap on the regulator.

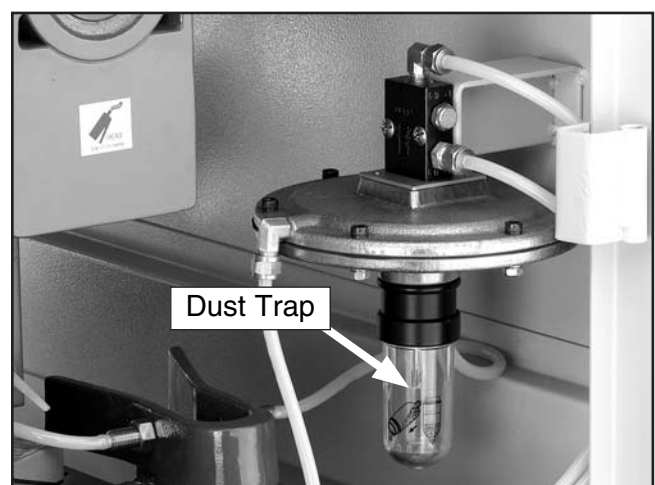

**Figure 21.** Unscrew the clear canister to empty the air line dust trap.



# SECTION 7: SERVICE

## Table Calibration

### NOTICE

The digital thickness gauge has been calibrated at the factory and should require no further adjustment. However, we recommend verifying its accuracy.

Use the first board fed through the sander to test the accuracy of the digital thickness gauge.

#### To calibrate the digital thickness scale:

1. Using a properly set-up planer, plane a board to uniform thickness.
2. Lower the sander table far enough to place the planed board under the sander roller.
3. Manually raise the table until the board just touches the sanding roller.
4. Remove the board without changing the table height. This ensures the table will be properly adjusted for the first sanding pass.
5. Run the board through the sander several times at the initial height setting. Manually raise the table 0.020" and pass the board through the sander several more times.
6. Measure the thickness at various points around the board using a precise micrometer or set of calipers. Continue sanding the board at that height until the average thickness measurement is within  $\pm 0.003$ ".

**Note:** These final passes should be done without adjusting the table height. This ensures the most consistent average thickness.

7. Observe the digital display read-out, it should indicate the average thickness of the sanded wood.

—If it does, the sander is properly calibrated and accurate to the nearest 0.005".

—If it does not, you must recalibrate the digital thickness scale.

#### To recalibrate the digital thickness scale:

1. Without moving the table height, enter the numerical measurement of the average thickness of the sanded wood into the digital key pad on the control panel.

**Note:** The average thickness of the sanded wood should now be flashing on the digital read-out.

2. Press and hold the  key until the display stops flashing. The sander is now correctly calibrated.

## Platen Service

#### To replace the platen felt and graphite pad:

1. DISCONNECT THE SANDER FROM THE POWER SOURCE!
2. Open the left access door and use the platen tool, as shown in **Figure 22** to remove the platen.
3. Replace platen felt pad and graphite pad.
4. Reinsert the platen until it stops.
5. Close the access door.



**Figure 22.** Removing platen.

G9979/G9980 Wide-Belt Sander



# Brake Service

Tools Needed:	Qty
Open End Wrench 14mm.....	1
Small Snap Ring Pliers .....	1
Hex Wrench 6mm.....	1
Phillips Screwdriver #2 .....	1

Eventually the brake pads will wear out. Checking and replacing these is a simple project that can be done in the shop, with the exception of having the rotor resurfaced on a lathe.

## To check the brake pads:

1. DISCONNECT THE SANDER FROM THE POWER SOURCE AND REMOVE AIR PRESSURE COMPLETELY!
2. Remove the four screws that secure the access panel on the right-hand side of the machine.
3. The brake caliper is located underneath the rotor, which is attached to the motor arbor.
4. The brake pads consist of a metal plate with a composite pad. With a fine ruler, measure the thickness of the composite pad only. If one of the pads is below  $\frac{1}{8}$ " (approx. 3mm, replace both.

## To replace the brake pads:

1. DISCONNECT THE SANDER FROM THE POWER SOURCE AND REMOVE AIR PRESSURE COMPLETELY!
2. Remove the nuts from the two mounting bolts and the two snap rings from the mounting pins behind the bracket (see **Figure 23**).

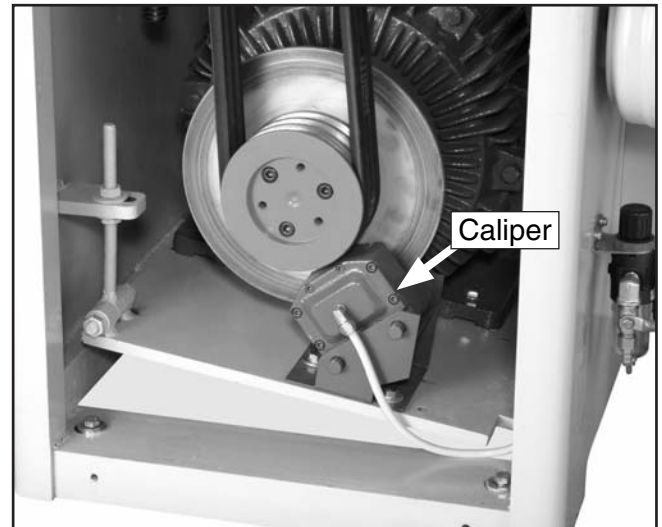

**Figure 23.** Disc brake.

3. Pull the mounting pins out of the caliper bracket and remove the air line from the caliper. The caliper should now be able to be removed.
4. Disassemble the brake caliper and remove the cap screws securing the brake pads.
5. Remove the brake rotor and have it professionally resurfaced at an automotive machine shop if it has gouges in it. If visible cracks are present in the brake rotor, replace it with a new one. Remove oil and dirt from the rotor with automotive brake cleaner. Once clean, only handle the rotor with a dry rag and reassemble onto the hub in reverse order.
6. Install new brake pads, mount the caliper and reconnect the air line.
7. Test the safety shutdown operation by running the sander and pressing the emergency stop controls.



# Oscillation Timing

## NOTICE

The oscillation adjustments have been performed at the factory and should require no further attention. However, we recommend verifying the settings.

When the oscillation is correctly adjusted, the sanding belt oscillates to the left and to the right at the same speed. If the sanding belt makes contact with a limit switch, as shown in **Figure 24**, the emergency braking system will activate and stop the sander immediately.

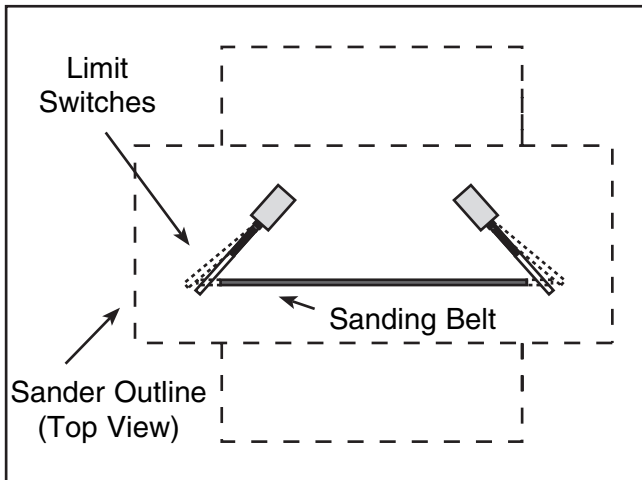
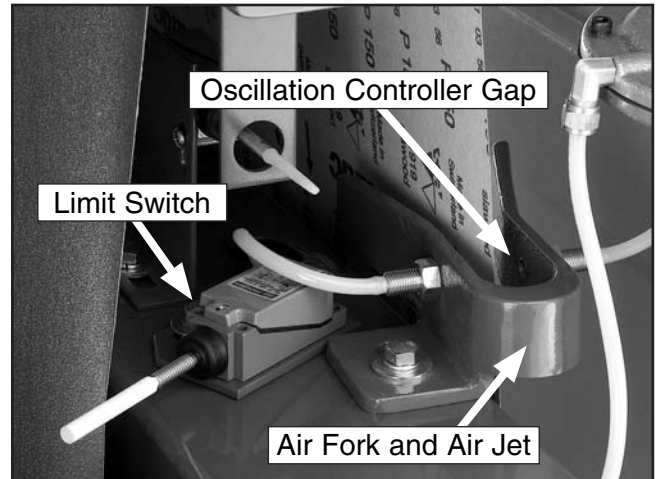

**Figure 24.** Improper oscillation.

### To check the sanding belt oscillation:

1. Be sure the sanding belt is properly installed and the belt tension knob and air supply are on.
2. Turn **ON** the sanding belt motor.
  - If the belt oscillates without contacting the limit switches, but the oscillation time to the left and right are **NOT** equal, proceed to **Step 6**, on **Page 33**.
  - If the belt tracks away from the air fork and air jet, colliding into the limit switch, continue with **Step 3**.

3. An adequate stream of air through the air fork gap (**Figure 25**) is essential for proper oscillation. If the jet of air is weak through the gap, the belt will track away from the controller and into the limit switch on the opposite end of the roller. The pivot action of the upper roller, and the resulting oscillation of the belt, are dependent upon adequate airflow through the air fork gap.



**Figure 25.** Oscillation components.

### To set the correct amount of airflow through the air fork gap:

1. Remove the sanding belt and turn the belt tension knob to the tensioned position.
2. Loosen the lock nut on the airflow adjustment knob (**Figure 26**).
3. Turn the airflow adjustment knob (**Figure 26**) clockwise until the airflow is completely **OFF**. The upper roller should pivot to the right.
4. Slowly turn the airflow adjustment knob counterclockwise, and continue turning up the air pressure until the roller pivots to the left.

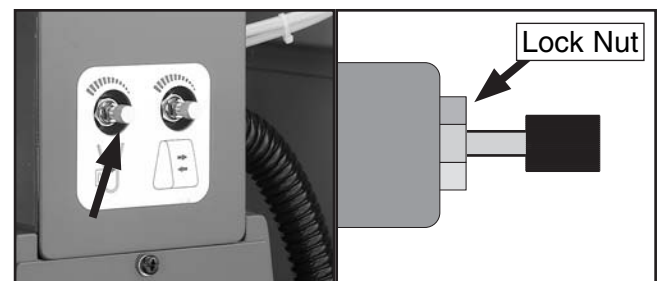

**Figure 26.** Airflow adjustment knob.



5. Tighten the lock nut (**Figure 26**) to secure the airflow adjustment knob.
6. Restrict the airflow across the air fork gap with a scrap piece of wood. You should notice the roller pivot to the right. When the scrap wood is removed, the roller should pivot back to the left.
7. Test the oscillation by running the sander. Make note of the time it takes for the belt to oscillate from left-to-right and from right-to-left.

When correctly timed, the oscillation should take a similar amount of time to oscillate.

—If the oscillation time to the **right** is 2 seconds, but the oscillation time to the **left** is longer, loosen the oscillation adjustment knob (**Figure 27**) and move it to the **left** until proper tracking is achieved. Tighten down the oscillation adjustment knob when satisfied.

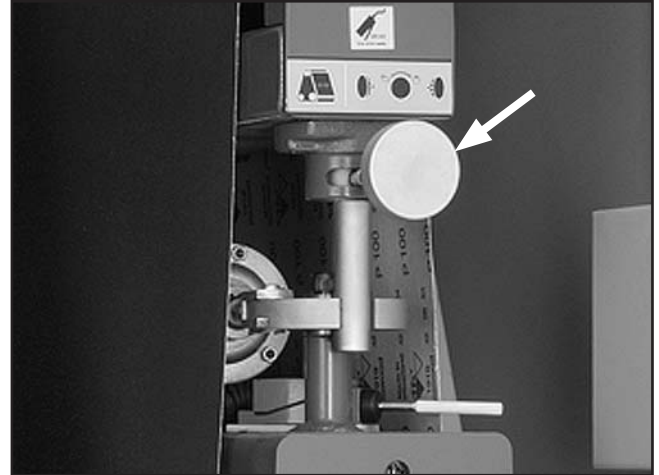

**Figure 27.** Oscillation adjustment knob.

—If the oscillation time to the **left** is 2 seconds, but the oscillation time to the **right** is longer, loosen the oscillation adjustment knob and move it to the **right** until proper tracking is achieved. Tighten the oscillation adjustment knob when satisfied.

8. Continue to the next page to adjust the oscillation speed.



# Oscillation Speed

The oscillation speed of the sanding belt is adjustable. Different oscillating speeds yield different sanding results. We recommend trying various speeds on a scrap piece of wood similar to the final workpiece.

## To adjust the oscillation speed:

1. Loosen the lock nut on the speed control adjustment knob (**Figure 28**).

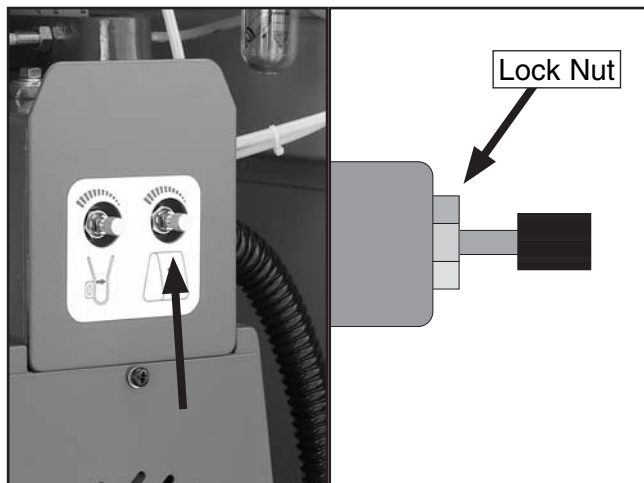

**Figure 28.** Speed control adjustment knob.

2. Turn the knob clockwise to decrease the oscillation speed and counterclockwise to increase it.
3. Tighten the lock nut loosened in **Step 1** to secure the knob.

# Table Parallelism

## NOTICE

The table has been adjusted at the factory and should require no further attention. However, we recommend verifying that it is parallel with the sanding roller.

The corners of the table can be independently adjusted up or down. By disconnecting the chain and turning the pertinent table elevation screw sprocket (**Figure 29**), table parallelism can be achieved.

Adjusting the table parallelism can be a very tedious task that takes a great amount of patience. DO NOT adjust the table unless you are having trouble sanding your workpiece to a uniform thickness.

If a table adjustment is needed, take precise notes on the positioning of the table elevation screws. This will allow the original setting to be re-established.

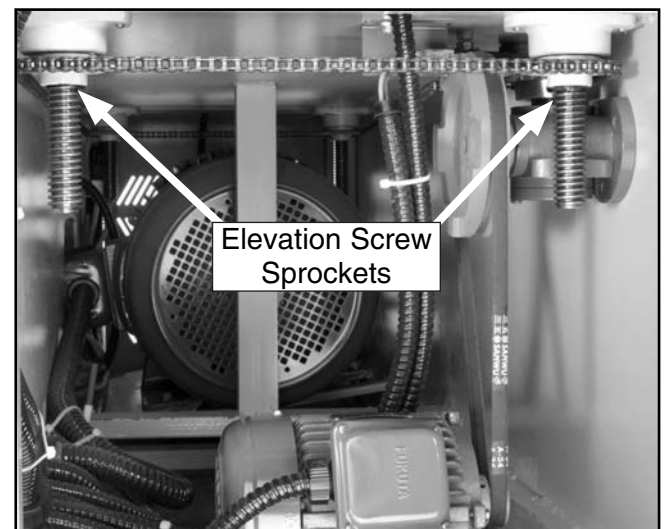

**Figure 29.** View of elevation screw sprockets.



### To adjust the table parallelism:

1. Pass a 37" wide board through the sander until the **entire** surface of the board is making contact with the sanding belt.
2. Measure the thickness of the board at various points around the edge.
3. If there is a variation of thickness, the table can be adjusted accordingly.
4. **DISCONNECT THE SANDER FROM THE POWER SOURCE!**

—For minor adjustment, loosen the table mounting bolts shown in **Figure 30** and rotate the elevation screw flange.

—For major adjustment, mark the chain location on all sprockets, remove the chain from the sprocket to be adjusted, and turn the sprocket counterclockwise to raise the table. One quarter of a turn raises or lowers an elevation screw approximately 0.020".

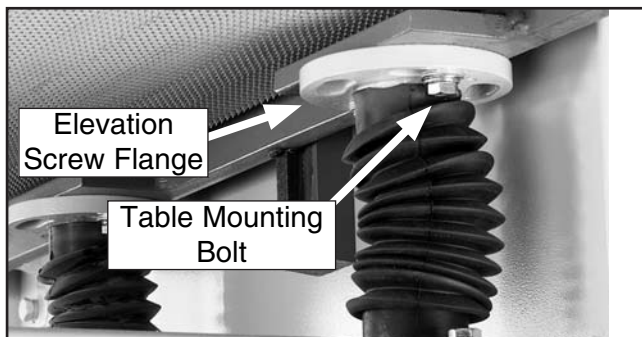

**Figure 30.** Table mounting bolts.

## NOTICE

**When adjusting the left front elevation screw, make the same adjustment to the left rear elevation screw. This ensures the height from the front to the back of the table remains unchanged. Do the same when adjusting the right elevation screws.**

5. Reinstall the chain, tighten the bolts, and test the machine.

# Pressure Rollers

### To adjust the pressure rollers:

1. **DISCONNECT THE SANDER FROM THE POWER SOURCE!**
2. Plane a 72" long 2x4 to a uniform thickness and cut it in half. Place one board along the length of the feed belt on the right-hand side and place the other board on the left-hand side.
3. With the sanding belt tensioned (**Figure 31**), move the sanding rollers by hand and manually raise the table until you hear the sandpaper just contact the surface of the wood. **DO NOT** continue to raise the table beyond that point.



**Figure 31.** Belt tension knob.

4. Connect the sander to the power source and make note of the reading on the digital display. Then manually lower the table 0.020" to 0.030". This is how much lower the infeed pressure roller should be set when compared to the sanding surface of the sanding roller.
5. **DISCONNECT THE SANDER FROM THE POWER SOURCE!**



- Loosen the roller lock nuts (**Figure 32**) on the infeed pressure roller. Turn the Adjustment Bolts (**Figure 32**) to lower the pressure roller until it just touches the board.

**Note:** DO NOT continue to lower the roller beyond that point.

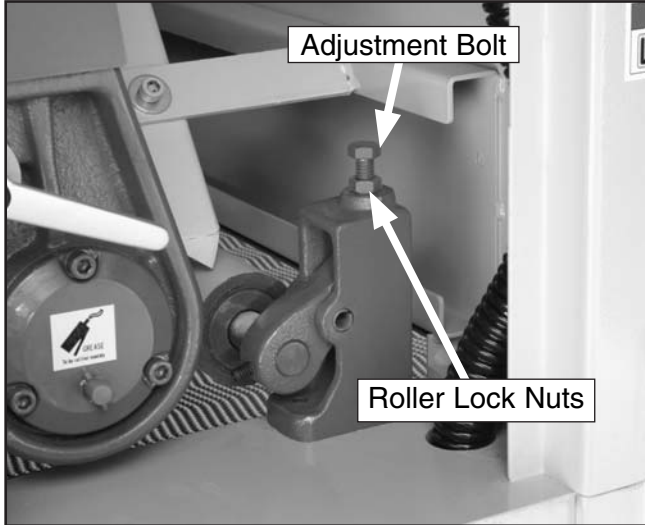

**Figure 32.** One pressure roller adjustment location.

- Tighten the roller lock nuts.
- Connect power to the sander and observe the reading on the digital display. Then manually lower the table an additional 0.020" to 0.030".
- Loosen the roller lock nuts on the outfeed pressure roller. Turn the adjustment bolts and lower the pressure roller until it just touches the board. **Note:** DO NOT continue to lower the roller beyond that point.
- Tighten the roller lock nuts.

**Note:** Variables such as feed rate, depth of the cut, and the type of sanding belt can play a big part in determining the proper amount of downward pressure exerted by the rollers. Experimentation is necessary to get the desired results. However, under no circumstances should the pressure rollers be set even, or higher than, the sanding roller.

## V-Belt Adjustment

To adjust either V-belt:

- DISCONNECT THE SANDER FROM THE POWER SOURCE!
- Loosen the lock nut (**Figures 33 & 34**).

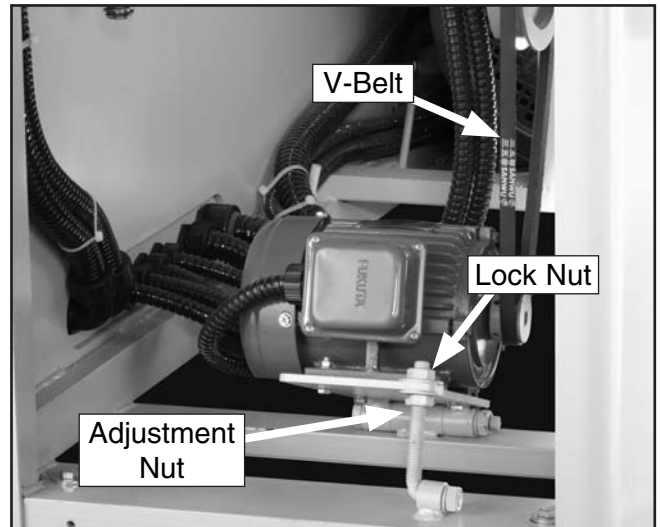

**Figure 33.** Table elevation V-belt.

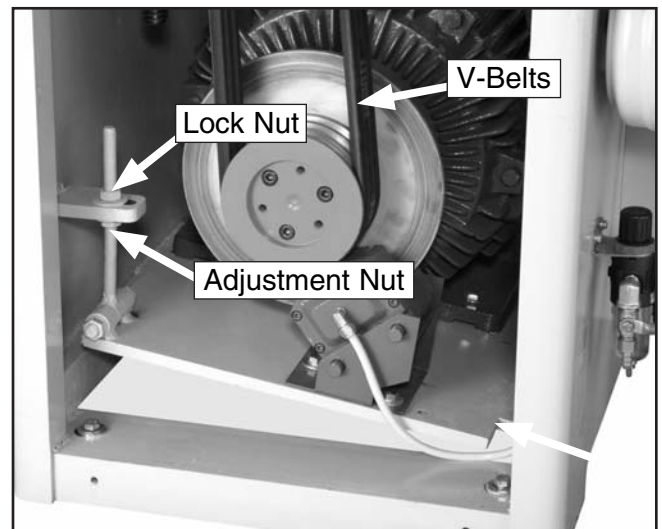

**Figure 34.** Sanding drum V-belts.

- Turn the adjustment nut up or down until the V-belts deflect 1" off of center when pushed with your finger.
- Retighten the lock nut.



# Conveyor Belt Replacement

## Tools Needed:

## Qty

Make sure that you have a lifting device or another person to help in table removal.

Hex Wrench 9mm.....	1
Combination Wrench 19mm.....	1
Combination Wrench 12mm.....	1
Combination Wrench 14mm.....	1
Phillips Screwdriver #2.....	1
2x4s, 8 foot.....	2
Permanent Marker.....	1

To remove the conveyor belt use **Figure 36** and follow the steps below:

1. Raise the table up so the conveyor belt is approximately two-inches away from the sanding roller or platen, and then **DISCONNECT THE SANDER FROM THE POWER SOURCE!**
2. Remove the gearbox mounting bracket, and with an assistant's help, slide the motor and gearbox from the roller shaft and lower it to the floor.  
  
**Note:** Do not loosen the two vibration dampener washers shown in **Figure 36**.
3. Remove two table height limit switches.
4. Remove both lower access panels.
5. Remove the left and right table guides.
6. Using a permanent marker, mark all four lead screw flange positions (**Figure 35**), and remove all hex bolts from the flanges.

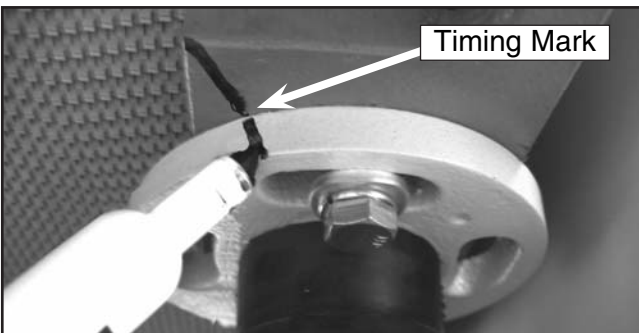

**Figure 35.** Marking lead screw for reassembly.

7. Insert the two 2x4 wooden studs under the table to support the table. With the help of another person, lift the table slightly and move it out of the rear of the machine.
8. Disconnect the limit switch, remove all mounting screws, and remove the emergency stop push-panel assembly.
9. Turn both tracking adjustment bolts counter-clockwise five turns, remove one roller support, and slide the drum out of the table assembly.
10. Remove the old conveyor belt, inspect rollers, bearings, table for wear and replace as required.
11. Install the new conveyor belt.  
**Note:** The belt is non-directional.
12. Install the front roller, the roller support, and turn both tracking adjustment bolts clockwise equally so the conveyor belt becomes taut and does not hang loose. **DO NOT OVERTIGHTEN** the belt.
13. With a helper, install the table from the rear in a similar fashion as it was removed.
14. Install the table guides and the left/right lower access panels.
15. Align the lead screw flanges with the marks made in **Step 6**, and install the hex bolts.
16. Install the table height limit switches so the upper switch clicks when the conveyor surface is 1/4" away from the sandpaper, and the lower switch clicks when the conveyor table is 1/4" higher than its lowest position. Make sure that you test your settings with the handwheel manually so you don't crash the table if incorrectly set the first time around.
17. With a helper, install the gearbox, vibration dampener washers, and mounting bracket.
18. Install the emergency stop push panel assembly and the limit switch.
19. Start the conveyor motor and turn the conveyor tracking bolts as required until the conveyor belt tracks straight without loading up on one side of the table.



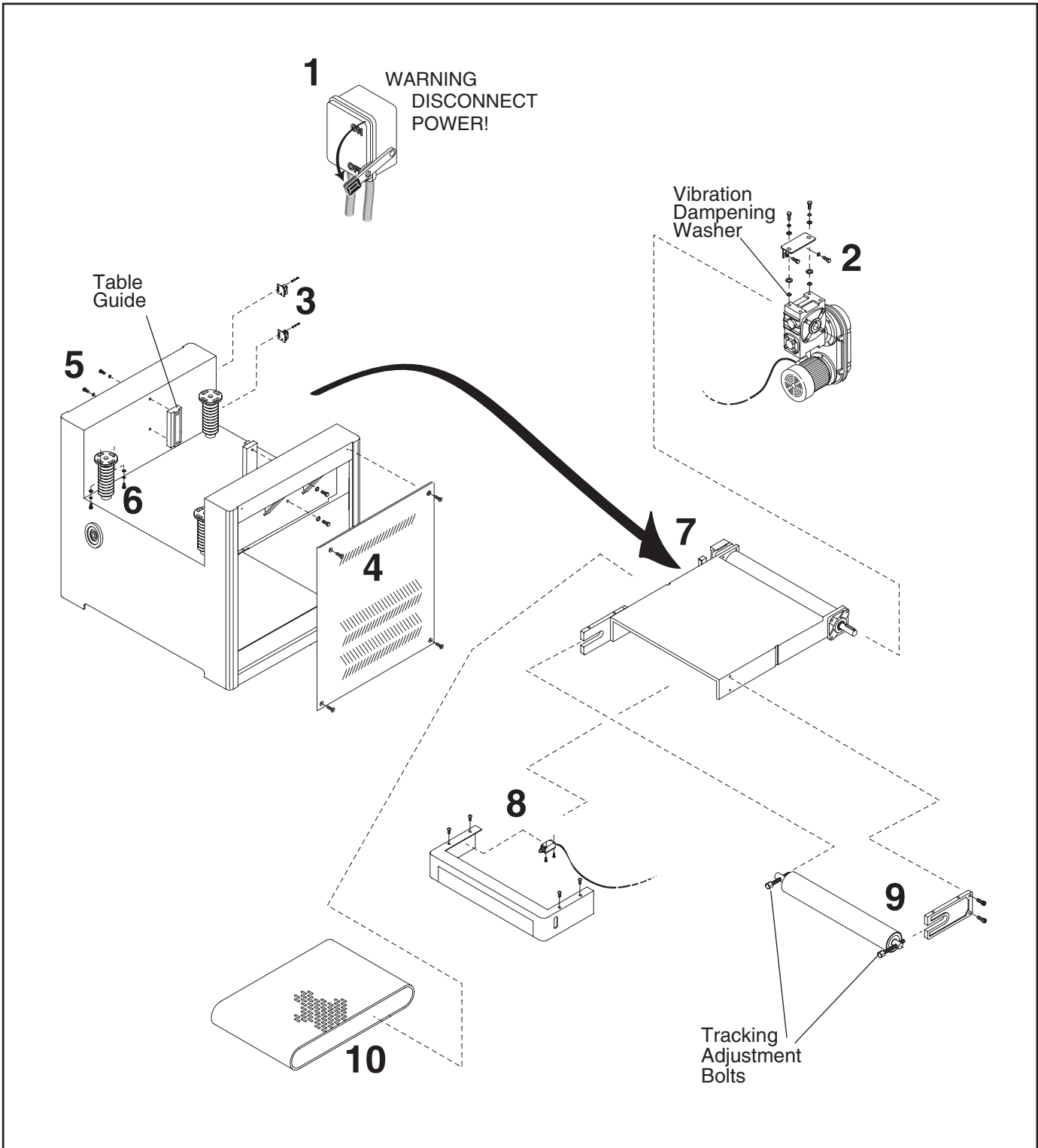

**Figure 36.** Conveyor belt removal sequence.



# Feed Belt Tension

Tools Needed:	Qty
Wrench or Socket 20mm.....	1
Phillips Screwdriver #2.....	1

## To adjust the feed belt tension:

1. DISCONNECT THE SANDER FROM THE POWER SOURCE!
2. Find the adjustment ports in the safety guard (**Figure 37**) at the front end of the feed table.
3. Turn both left and right adjustment bolts (**Figure 37**) clockwise equally to increase tension.

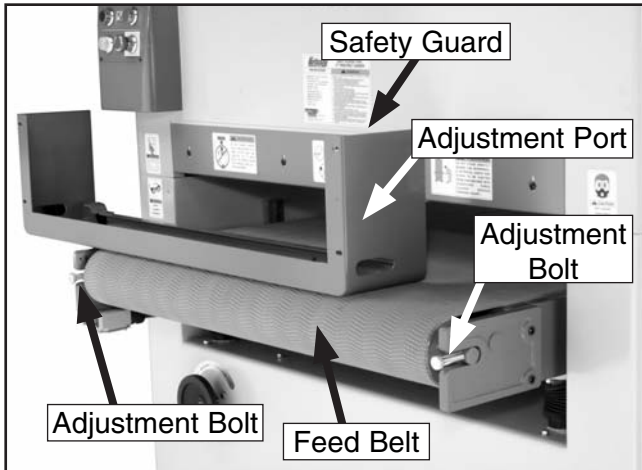

**Figure 37.** Feed belt tension adjustment bolts.

**Note:** Safety guard removed for clarity.

4. When tensioned properly you should not be able to lift the feed belt off of the table surface or slide it back and forth.

## **!WARNING**

**DO NOT sand boards with the guard removed. Failure to follow this warning could result in serious personal injury.**

# Feed Belt Tracking

Tools Needed:	Qty
Hex Wrench 6mm.....	1

## **NOTICE**

**Adjust the feed belt tension before adjusting the feed belt tracking.**

## To adjust the feed belt tracking:

1. Turn the feed belt **ON**.
2. If the feed belt is tracking to the **right** side of the table, turn the **right** adjustment bolt (**Figure 37**) clockwise.
3. If the feed belt is tracking to the **left** side of the table, turn the **left** adjustment bolt clockwise.

**Note:** The edge of the feed belt should just touch the guide wheels as shown in **Figure 38**.

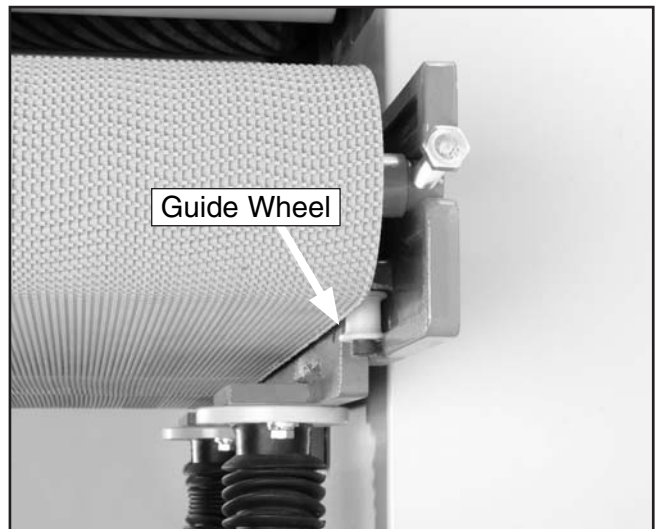

**Figure 38.** Guide wheels.

4. Run the feed belt for 3-5 minutes and recheck the tracking.
5. If the belt is still tracking correctly, replace the safety cover removed in the previous subsection.



# Air System Diagram

- A. Shop Compressor
- B. Air Pressure Regulator
- C. Emergency Brake Solenoid
- D. Emergency Brake
- E. Air Distribution Manifold
- F. Airflow Adjustment Knob (Oscillation Timing)
- G. Speed Control Adjustment Knob (Oscillation Speed)
- H. Oscillation Controller Air Fork
- I. Oscillation Timing Piston and Diaphragm Assy.
- J. Oscillation Speed Control Piston
- K. Belt Tension Control Piston
- L. Belt Tension Control Switch
- M. Emergency Stop Button Switch
- N. Emergency Stop Push Brake Switch
- O. Left Belt Limit Switch
- P. Right Belt Limit Switch
- Q. Belt Tension Limit Switch
- R. Emergency Brake Contactor

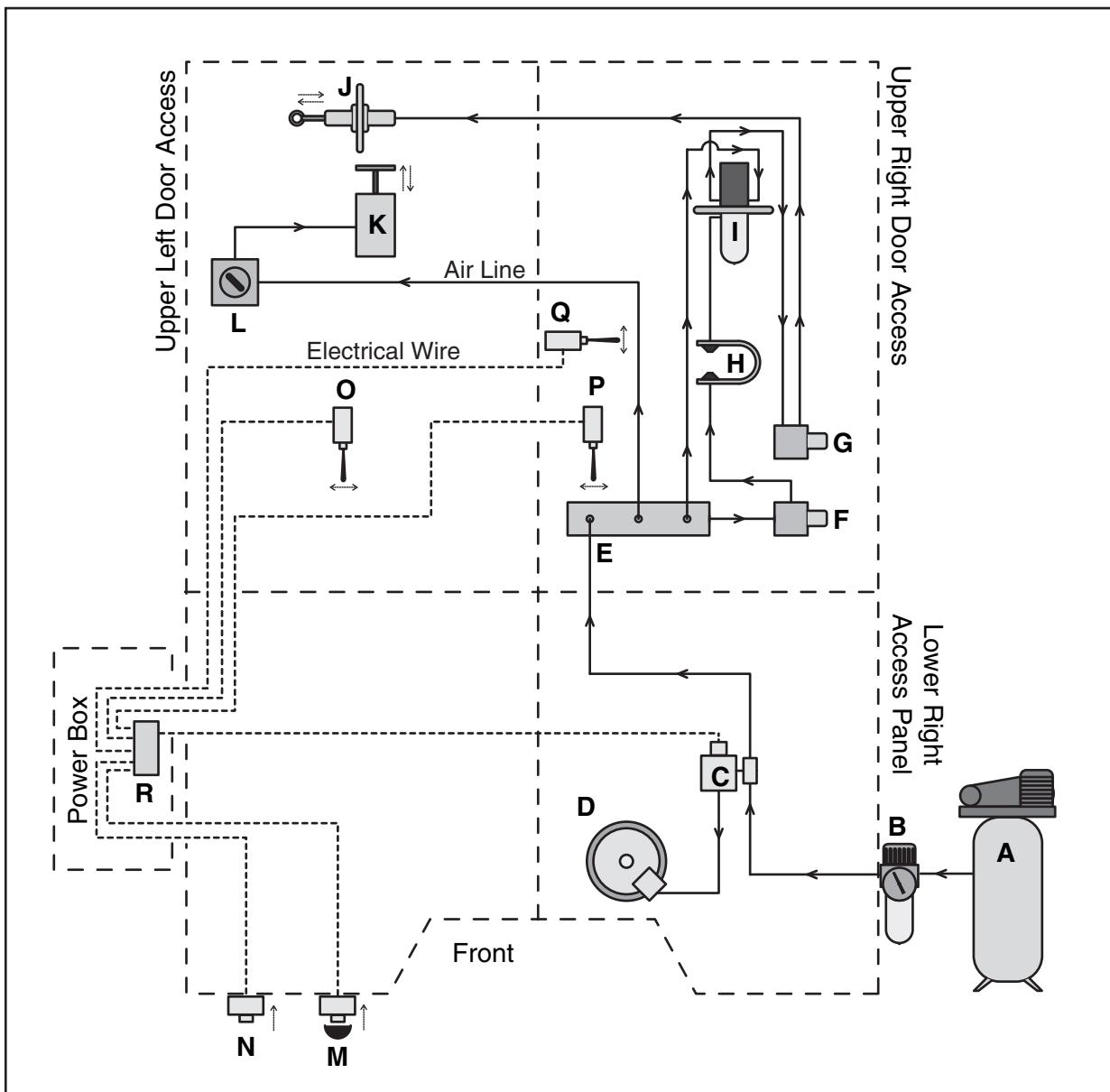

# Troubleshooting

SYMPTOM	POSSIBLE CAUSE	CORRECTIVE ACTION
Motor will not start.	<ol style="list-style-type: none"> <li>1. Limit switch or emergency stop is at fault.</li> <li>2. Low voltage.</li> <li>3. Open circuit in motor or loose connections.</li> </ol>	<ol style="list-style-type: none"> <li>1. Correct situation that caused limit switch to engage, reset the emergency stop button.</li> <li>2. Check power line for proper voltage.</li> <li>3. Inspect all lead connections on motor for loose or open connections.</li> </ol>
Motor will not start; fuses or circuit breakers blow.	<ol style="list-style-type: none"> <li>1. Short circuit in line cord or plug.</li> <li>2. Short circuit in motor or loose connections.</li> <li>3. Incorrect fuses or circuit breakers in power line.</li> </ol>	<ol style="list-style-type: none"> <li>1. Inspect cord or plug for damaged insulation and shorted wires.</li> <li>2. Inspect all connections on motor for loose or shorted terminals or worn insulation.</li> <li>3. Install correct fuses or circuit breakers.</li> </ol>
Motor overheats.	<ol style="list-style-type: none"> <li>1. Motor overloaded.</li> <li>2. Air circulation through the motor restricted.</li> </ol>	<ol style="list-style-type: none"> <li>1. Reduce load on motor.</li> <li>2. Clean out motor to provide normal air circulation.</li> </ol>
Motor stalls (resulting in blown fuses or tripped circuit).	<ol style="list-style-type: none"> <li>1. Short circuit in motor or loose connections.</li> <li>2. Low voltage.</li> <li>3. Incorrect fuses or circuit breakers in power line.</li> <li>4. Motor overloaded.</li> </ol>	<ol style="list-style-type: none"> <li>1. Inspect connections on motor for loose or shorted terminals or worn insulation.</li> <li>2. Correct the low voltage conditions.</li> <li>3. Install correct fuses or circuit breakers.</li> <li>4. Reduce load on motor.</li> </ol>
Machine slows when operating.	<ol style="list-style-type: none"> <li>1. Feed rate too high.</li> <li>2. Depth of cut too great.</li> </ol>	<ol style="list-style-type: none"> <li>1. Feed workpiece slower.</li> <li>2. Reduce depth of cut.</li> </ol>
Loud, repetitious noise coming from machine.	<ol style="list-style-type: none"> <li>1. Pulley set screws or keys are missing or loose.</li> <li>2. Motor fan is hitting the cover.</li> <li>3. V-belt is defective.</li> </ol>	<ol style="list-style-type: none"> <li>1. Inspect keys and set screws. Replace or tighten if necessary.</li> <li>2. Tighten fan or shim cover.</li> <li>3. Replace V-belt. Refer to the <b>Maintenance</b> section.</li> </ol>
Machine is loud, overheats or bogs down in the cut.	<ol style="list-style-type: none"> <li>1. Excessive depth of cut.</li> <li>2. Dull or dirty sanding belt.</li> </ol>	<ol style="list-style-type: none"> <li>1. Decrease depth of cut.</li> <li>2. Replace or clean sanding belt.</li> </ol>
Rounded workpiece edges.	<ol style="list-style-type: none"> <li>1. Excessive depth of cut.</li> </ol>	<ol style="list-style-type: none"> <li>1. Reduce depth of cut.</li> </ol>
Uneven thickness from left to right of board.	<ol style="list-style-type: none"> <li>1. Feed table not parallel to sanding roller.</li> <li>2. Conveyor belt is worn.</li> </ol>	<ol style="list-style-type: none"> <li>1. Adjust the table.</li> <li>2. Replace conveyor belt.</li> </ol>
Workpiece pads on feed belt.	<ol style="list-style-type: none"> <li>1. Pressure rollers set too high.</li> <li>2. Dirty conveyor belt.</li> <li>3. Conveyor belt is worn.</li> </ol>	<ol style="list-style-type: none"> <li>1. Lower pressure rollers.</li> <li>2. Clean conveyor belt.</li> <li>3. Replace conveyor belt.</li> </ol>
Straight strip of notches on workpiece.	<ol style="list-style-type: none"> <li>1. Pressure rollers are dirty or damaged.</li> </ol>	<ol style="list-style-type: none"> <li>1. Clean or repair pressure rollers.</li> </ol>
Snake shaped marks on workpiece.	<ol style="list-style-type: none"> <li>1. Sanding belt damaged or dirty.</li> </ol>	<ol style="list-style-type: none"> <li>1. Clean or replace sanding belt.</li> </ol>

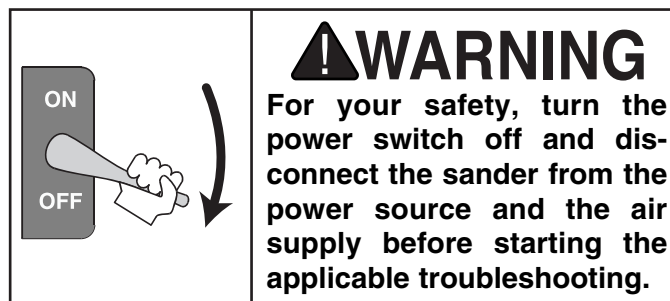

# Troubleshooting

SYMPTOM	POSSIBLE CAUSE	CORRECTIVE ACTION
Lines across width of workpiece.	1. Sanding belt seam is open or damaged.	1. Repair or replace sanding belt.
Glossy spots or streaks on workpiece.	1. Worn sanding belt. 2. Rear pressure roller too low.	1. Replace sanding belt. 2. Raise rear pressure roller. <b>(See warning in Pressure Roller section!)</b>
Sanding belt clogs quickly.	1. Sanding belt grit too small for particular job. 2. Excessive depth of cut. 3. Wood is too moist.	1. Replace with a coarser grit sanding belt. 2. Reduce depth of cut. 3. Allow wood to dry out.
Sanding belt does not tension correctly; rollers pad under belt.	1. Low air pressure. 2. Air leaks in system.	1. Adjust air pressure to 75 PSI at primary regulator. 2. Inspect all hoses and connections for leaking air; use water on suspected area to detect bubbles.
Sanding belt runs off to one side, stopping the sander.	1. Air eye fork clogged. 2. Oscillation return valve closed. 3. Oscillation timing incorrect.	1. Clean the intake hole on the air eye fork. 2. Open valve. 3. Adjust oscillation timing.
Sanding belt will not start.	1. Sanding belt is not tensioned. 2. Limit switches engaged. 3. Emergency stop plate engaged.	1. Tension sanding belt. 2. Center sanding belt so it is not touching the limit switches. 3. Make sure emergency stop switch is released.
Poor, non-aggressive sanding results.	1. Worn sanding belt. 2. Sanding belt loaded with sawdust.	1. Replace sanding belt with a new one. 2. Clean sanding belt to unload sawdust.
Conveyor belt not tracking in center.	1. Conveyor rollers moved out of adjustment.	1. Re-adjust conveyor rollers.
Conveyor belt slipping.	1. Conveyor rollers have incorrect tension. 2. Conveyor rollers contaminated with dirt or dust.	1. Adjust conveyor rollers to place more tension on the workpiece. 2. Clean conveyor rollers.
Emergency brake stops slowly.	1. Air pressure incorrect. 2. Air leak in system. 3. Brake rotor contaminated with oil. 4. Brake pads worn out.	1. Adjust air pressure to 75 PSI. 2. Find and fix air leaks. 3. Clean brake rotor with automotive brake parts cleaner. 4. Replace brake pads.
Grinding noise when braking.	1. Brakes severely worn out.	1. Replace brake pads, have rotor turned (possibly replaced).

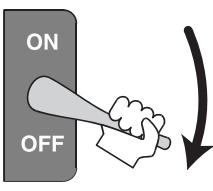

## ⚠ WARNING

**For your safety, turn the power switch off and disconnect the sander from the power source and the air supply before starting the applicable troubleshooting.**



# Notes

---

---



# Control Panel Component Locations

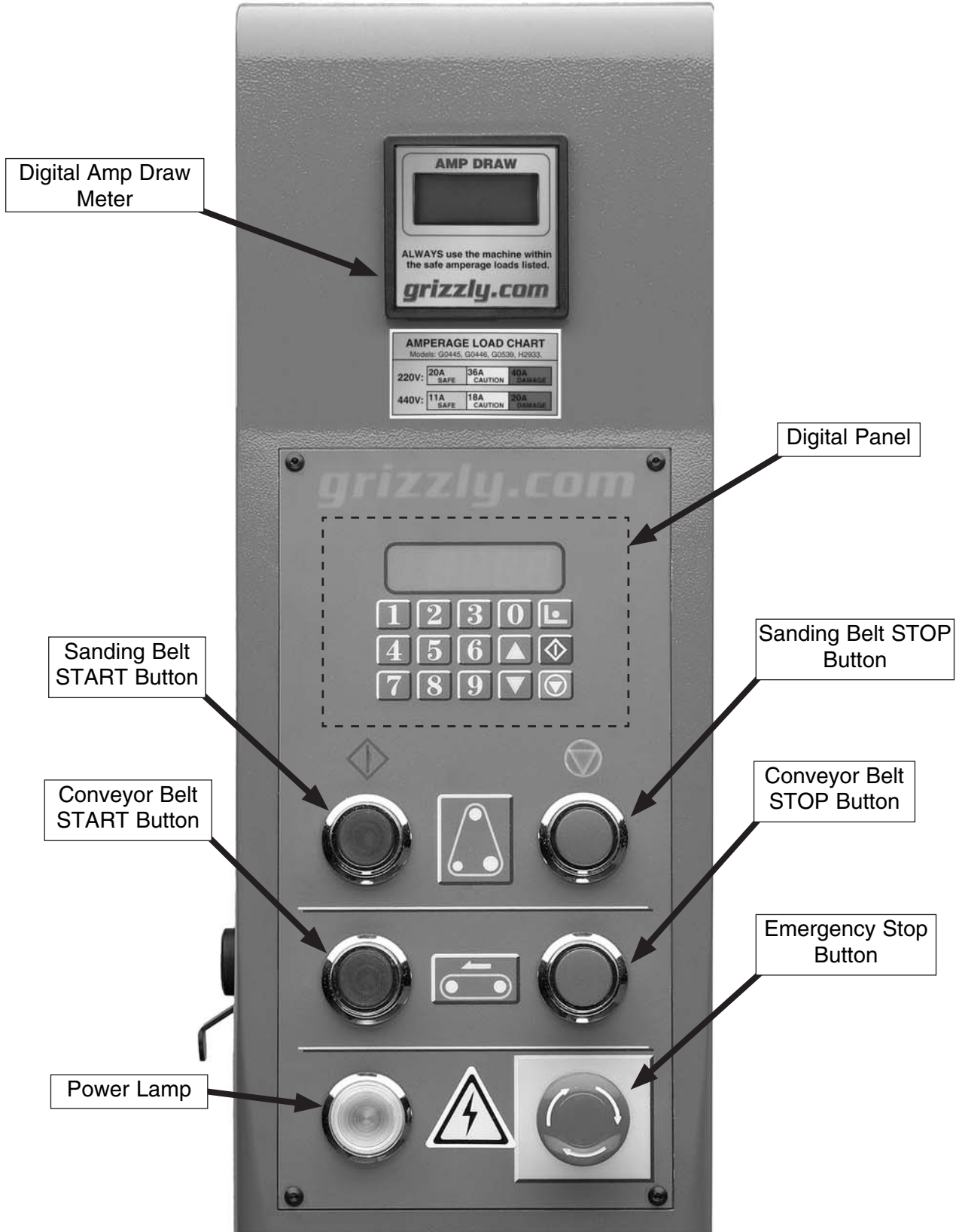

# Connection Wiring Diagram 220V/440V 3-Phase

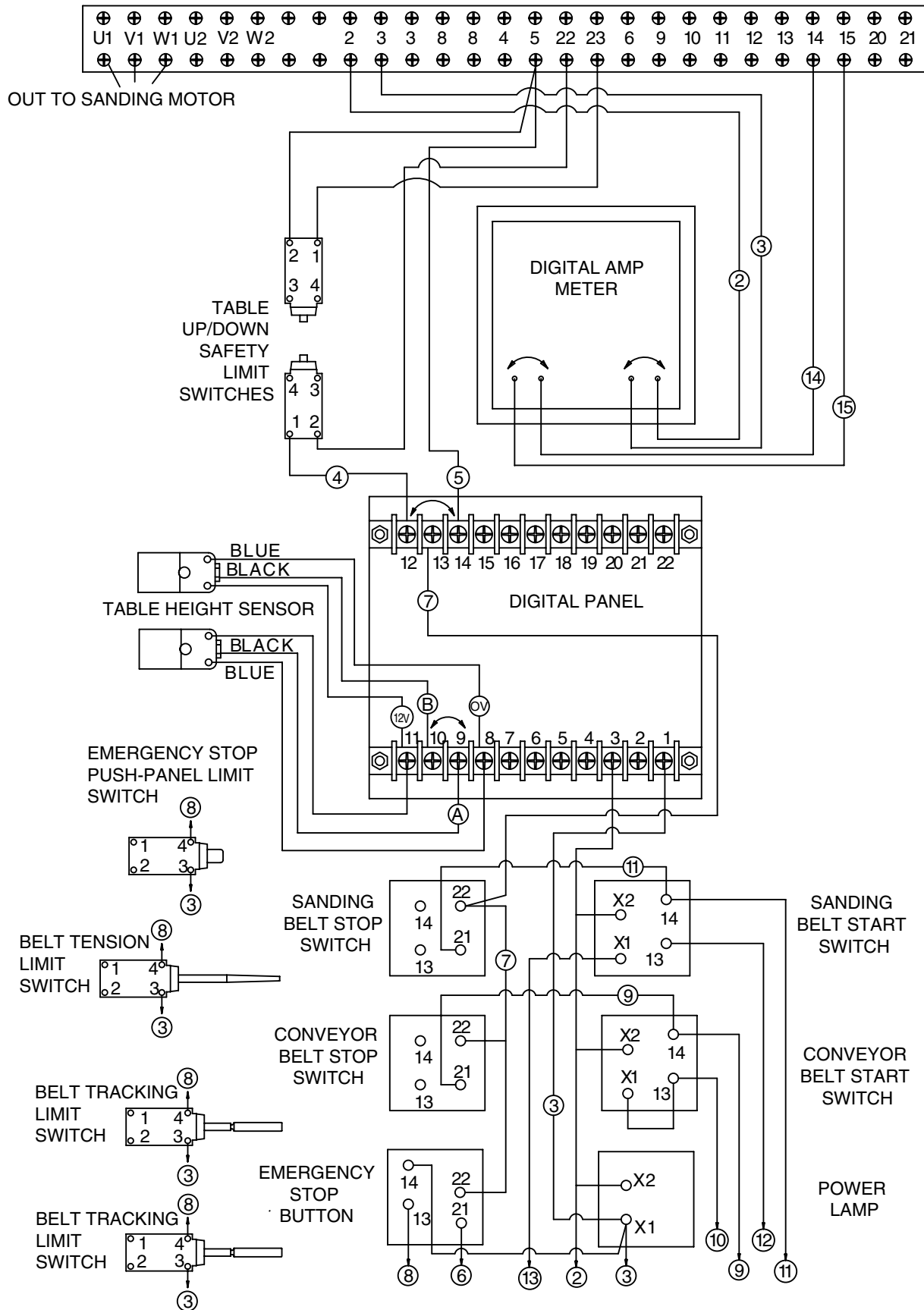

# General Electrical Diagram

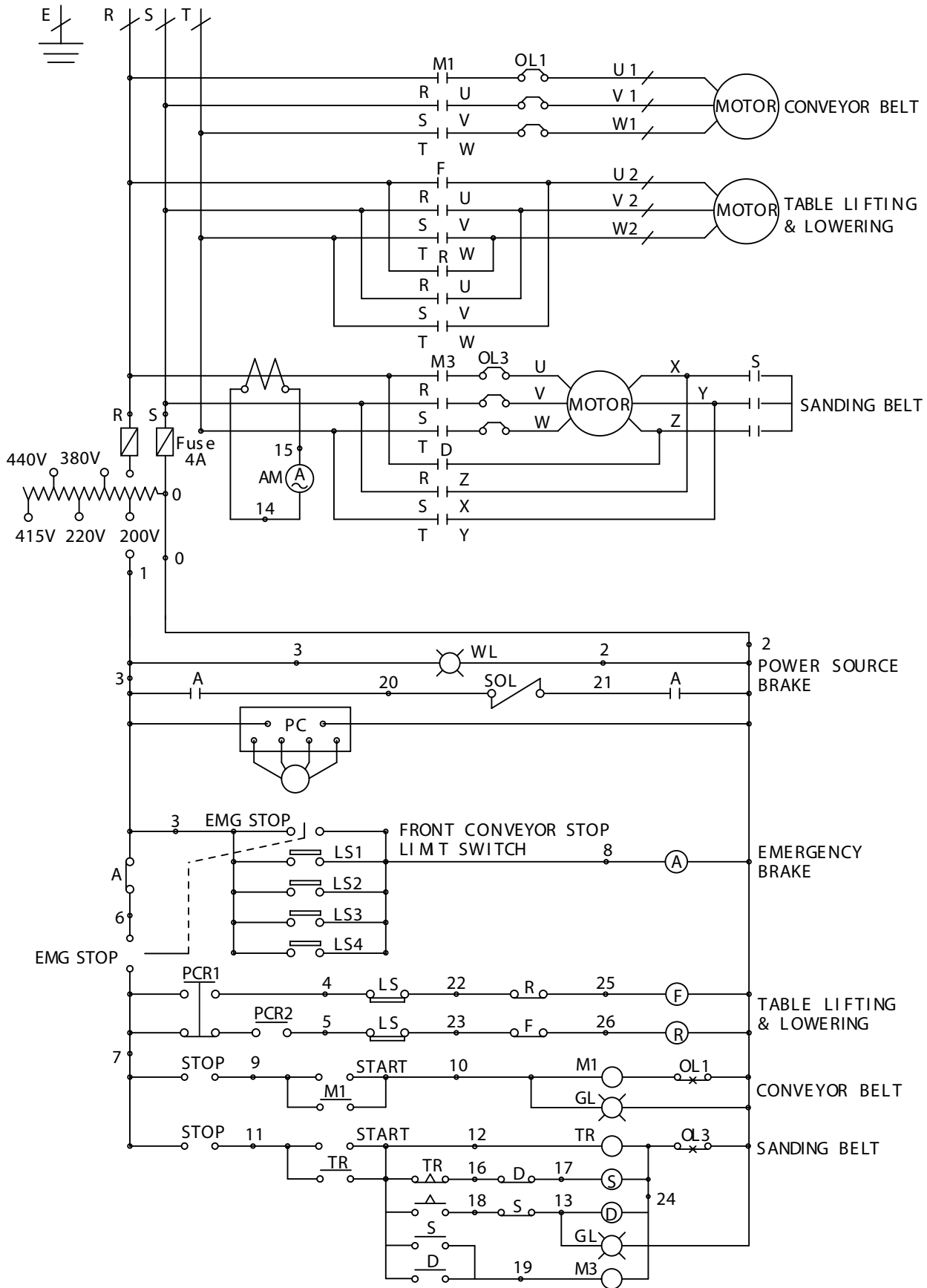

# Motor Connections Diagram

( STAR DELTA )

SANDING BELT MOTOR

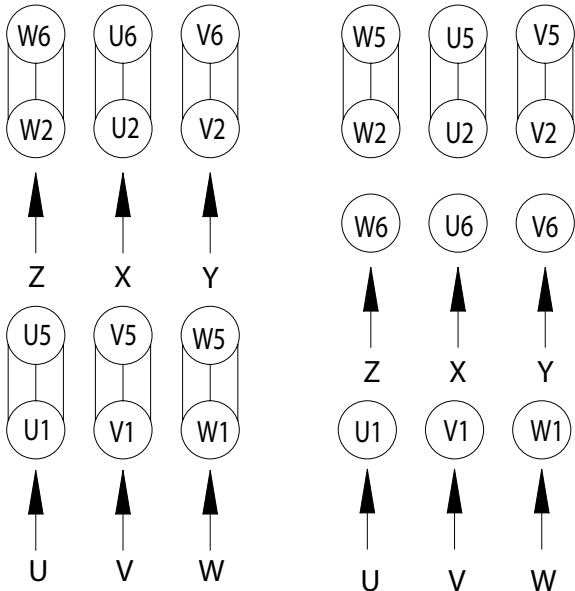

220V 3-Phase Connection

440V 3-Phase Connection

CONVEYOR BELT MOTOR

TABLE UP/DOWN MOTOR

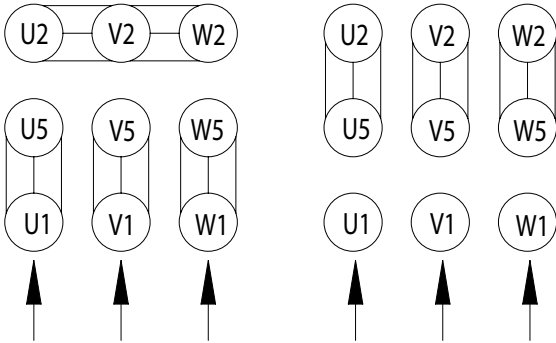

( CONVEYOR BELT )

U1 V1 W1 U1 V1 W1

( TABLE UP/DOWN )

U2 V2 W2 U2 V2 W2

220V 3-Phase Connection

440V 3-Phase Connection





# Wiring Box Components (G9979 220V/440V, G9980 440V)

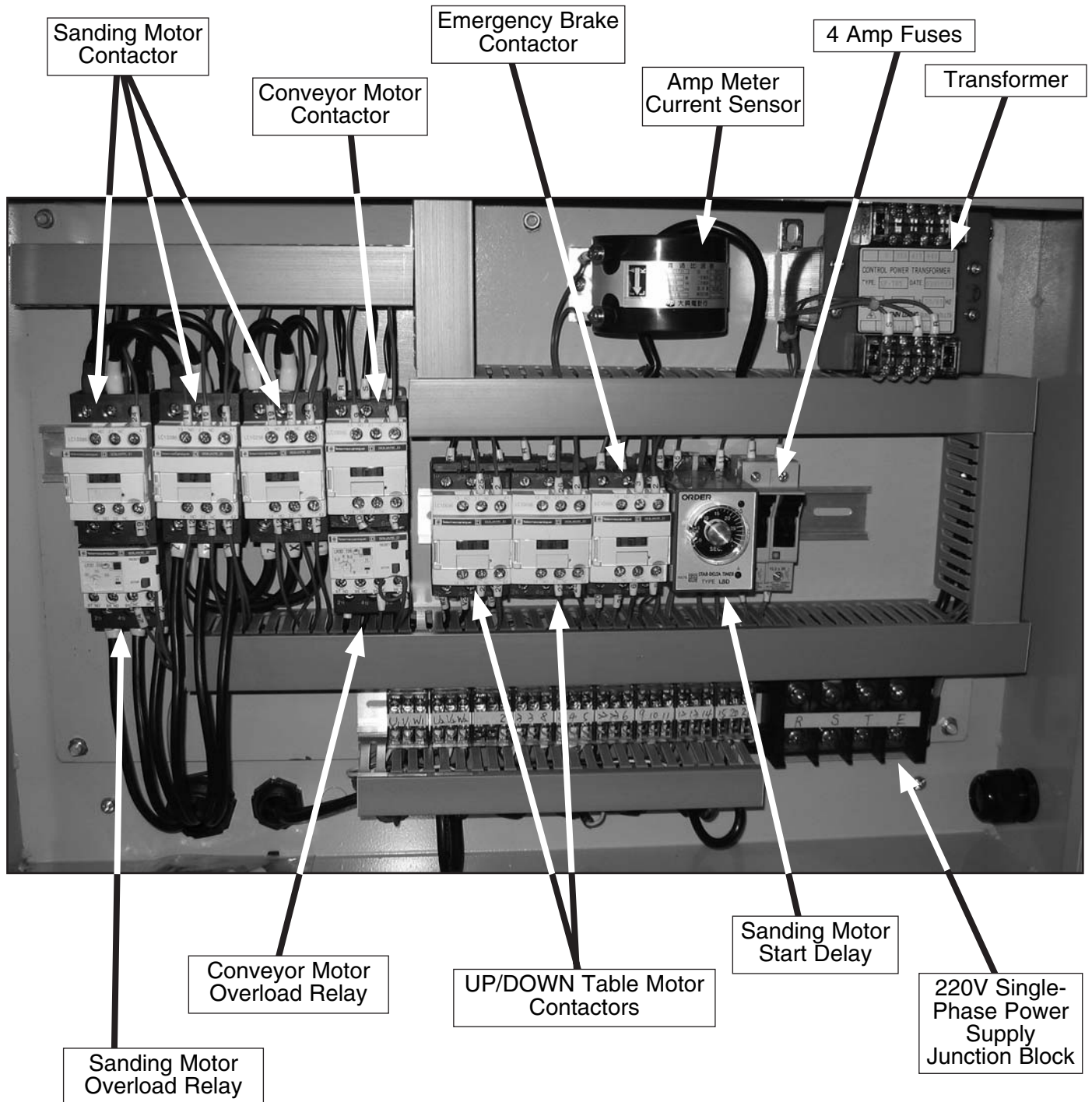

# Main Electrical Box Diagram (G9980 220V)

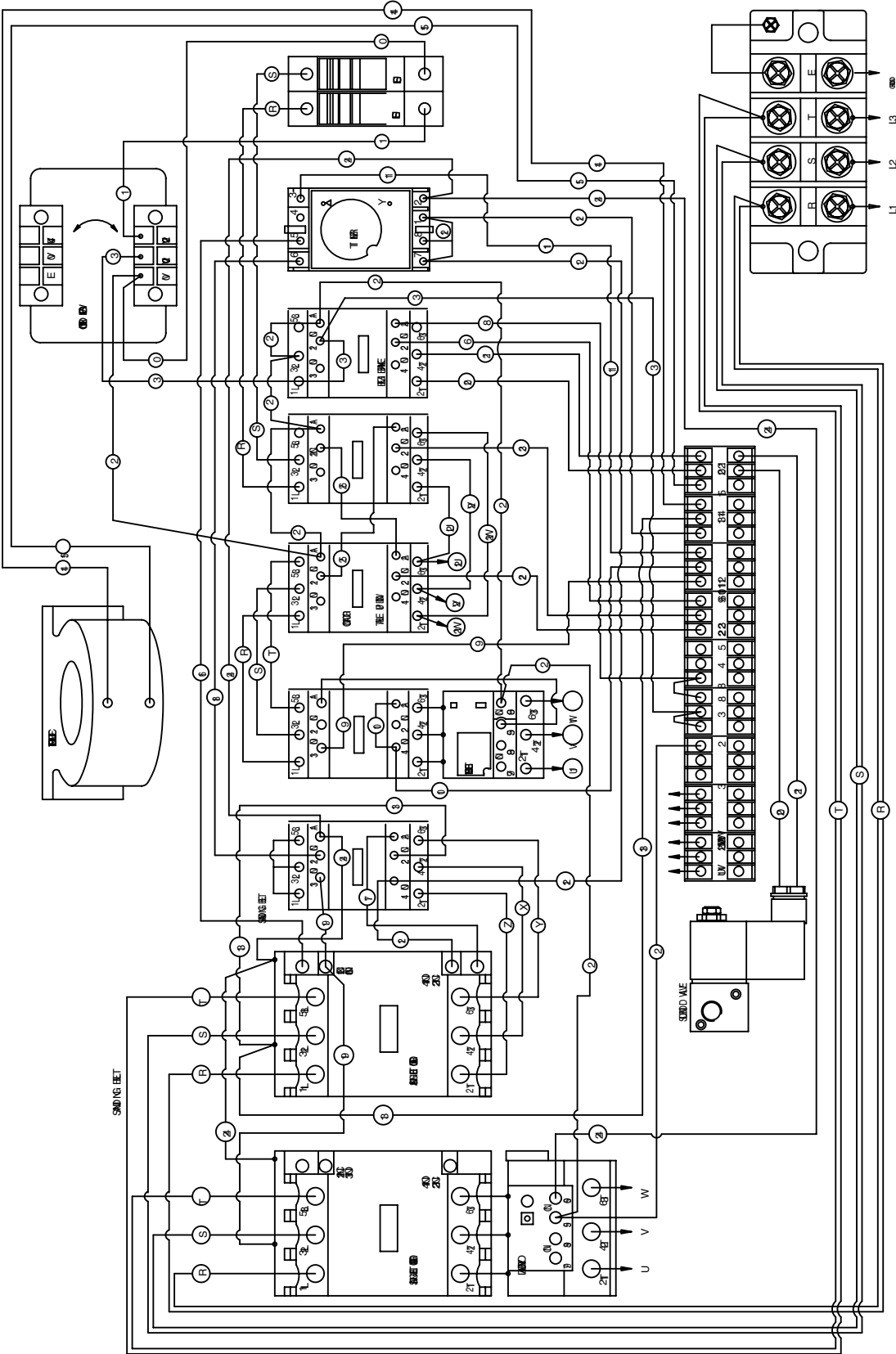

# Wiring Box Components (G9980 220V)

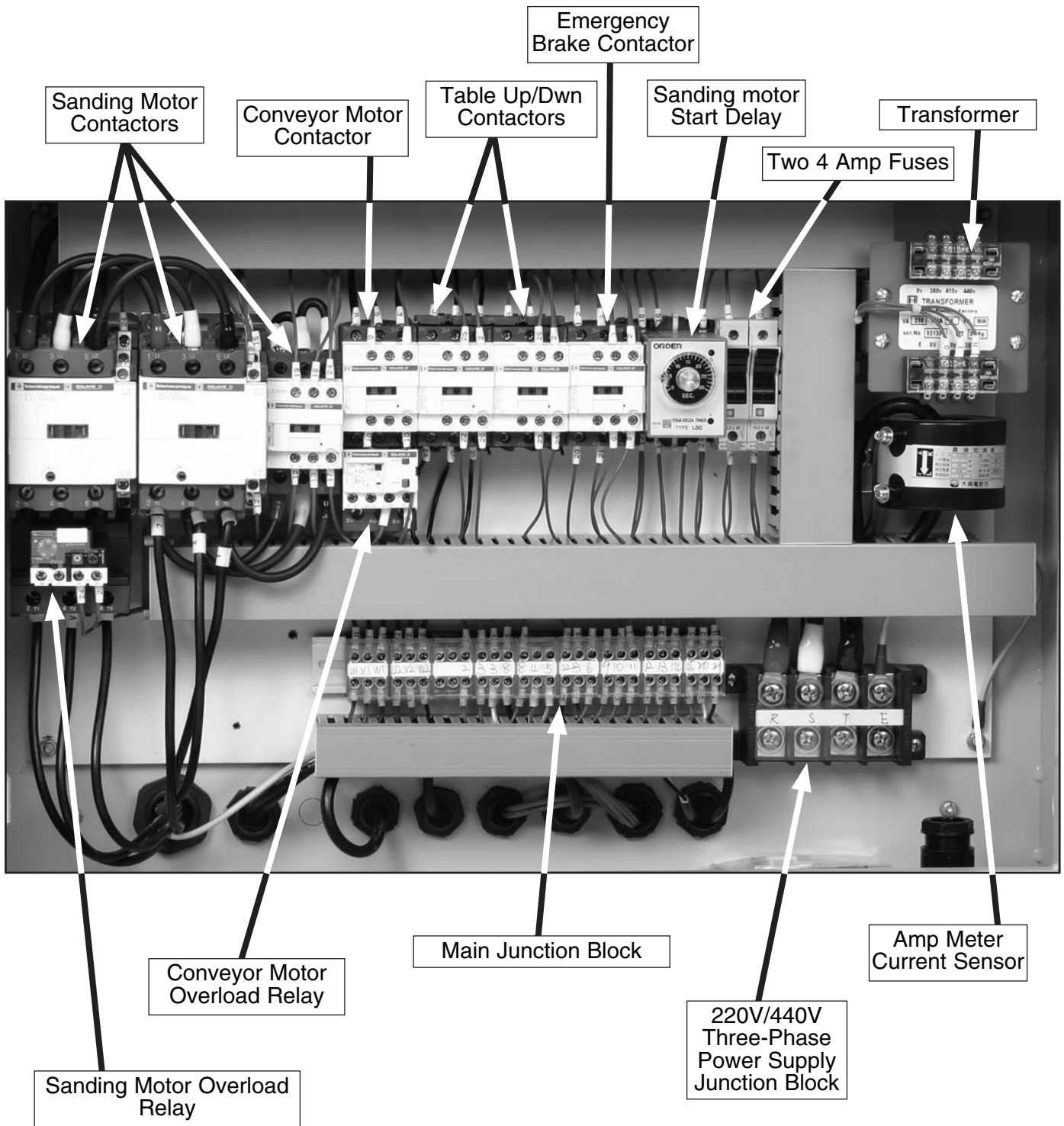

# SECTION 8: PARTS

## Tool Box and Accessories Diagram

---

---

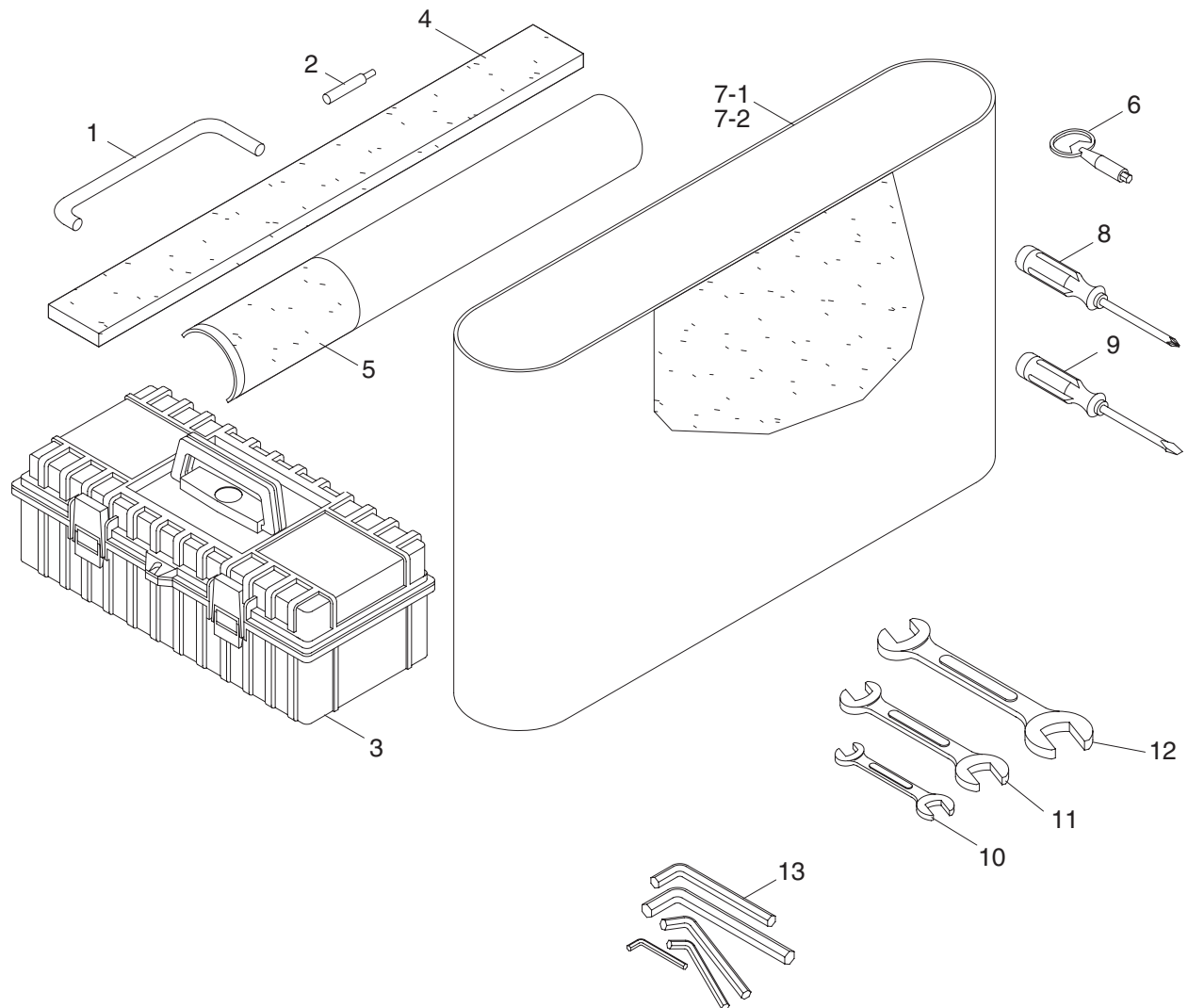

# Tool Box and Accessories Parts List

REF	PART #	DESCRIPTION
1	P99790001	PLATEN REMOVAL TOOL
2	P99790002	CERAMIC LIMIT SWITCH TUBE
3	P99790003	TOOL BOX
4	P99790004	FELT PAD (G9979)
4	P99800004	FELT PAD (G9980)
5	P99790005	GRAPHITE PAD (G9979)
5	P99800005	GRAPHITE PAD(G9980)
6	P99790006	DOOR KEY
7-1	P99790007-1	SANDING BELT: #100 (G9979)

REF	PART #	DESCRIPTION
7-1	P99800007-1	SANDING BELT: #100 (G9980)
7-2	P99790007-2	SANDING BELT: #180 (G9979)
7-2	P99800007-2	SANDING BELT: #180 (G9980)
8	P99790008	PHILLIP'S SCREWDRIVER
9	P99790009	FLAT SCREWDRIVER
10	PWR810	WRENCH 8 X 10
11	PWR1214	WRENCH 12 X 14
12	PWR1719	WRENCH 17 X 19
13	P99790013	HEX WRENCH SET



# Label Diagram

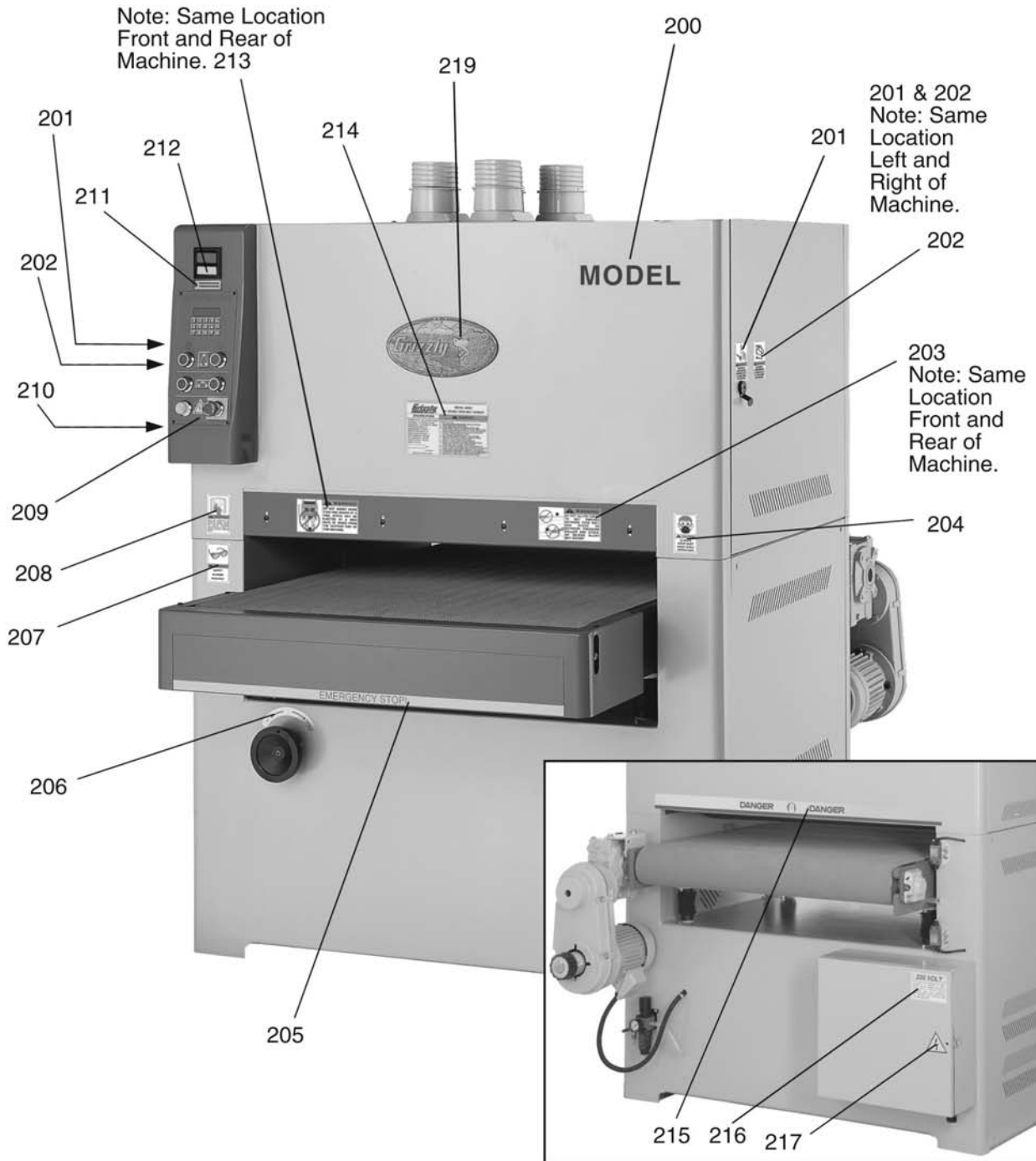

## **⚠️ WARNING**

Safety labels warn about machine hazards and ways to prevent injury. The owner of this machine **MUST** maintain the original location and readability of the labels on the machine. If any label is removed or becomes unreadable, **REPLACE** that label before using the machine again. Contact Grizzly at (800) 523-4777 or [www.grizzly.com](http://www.grizzly.com) to order new labels.



# Labels List

REF	PART #	DESCRIPTION
200	P9979200	LABEL (MODEL G9979)
200	P9980200	LABEL (MODEL G9980)
201	PLABEL13	LABEL (UNPLUG)
202	PLABEL-30	LABEL (CLOSE DOOR)
203	PLABEL-22	LABEL (HAND PINCH)
204	PLABEL-32	LABEL (USE RESPIRATOR)
205	P9962Z205	LABEL (EMERGENCY STOP)
206	P0582206	LABEL (ROTATION)
207	PLABEL-35	LABEL (SAFETY GLASSES)
208	PLABEL-12	LABEL (READ MANUAL)
209	P9962Z209	LABEL (CONTROL PANEL)
210	PLABEL-27	LABEL (CONVERSION CHART)

REF	PART #	DESCRIPTION
211	P9979211	LABEL (AMP LOAD FOR G9979)
211	P9980211	LABEL (AMP LOAD FOR G9980)
212	P0582212	LABEL (AMP METER)
213	PLABEL-16	LABEL (SANDER KICKBACK)
214	P9979112	LABEL (MACHINE DATA G9979)
214	P9980112	LABEL (MACHINE DATA G9980)
215	P9980215	LABEL (DANGER STRIPE)
216	P9979216	LABEL (PREWIRED: 220V, 3-PH)
216-1	P9979216-1	LABEL (PREWIRED: 440V, 3-PH)
217	P9962217Z	LABEL (ELECTRICAL)
219	G8589	GRIZZLY LOGO PLATE



# Sanding Motor System Diagram

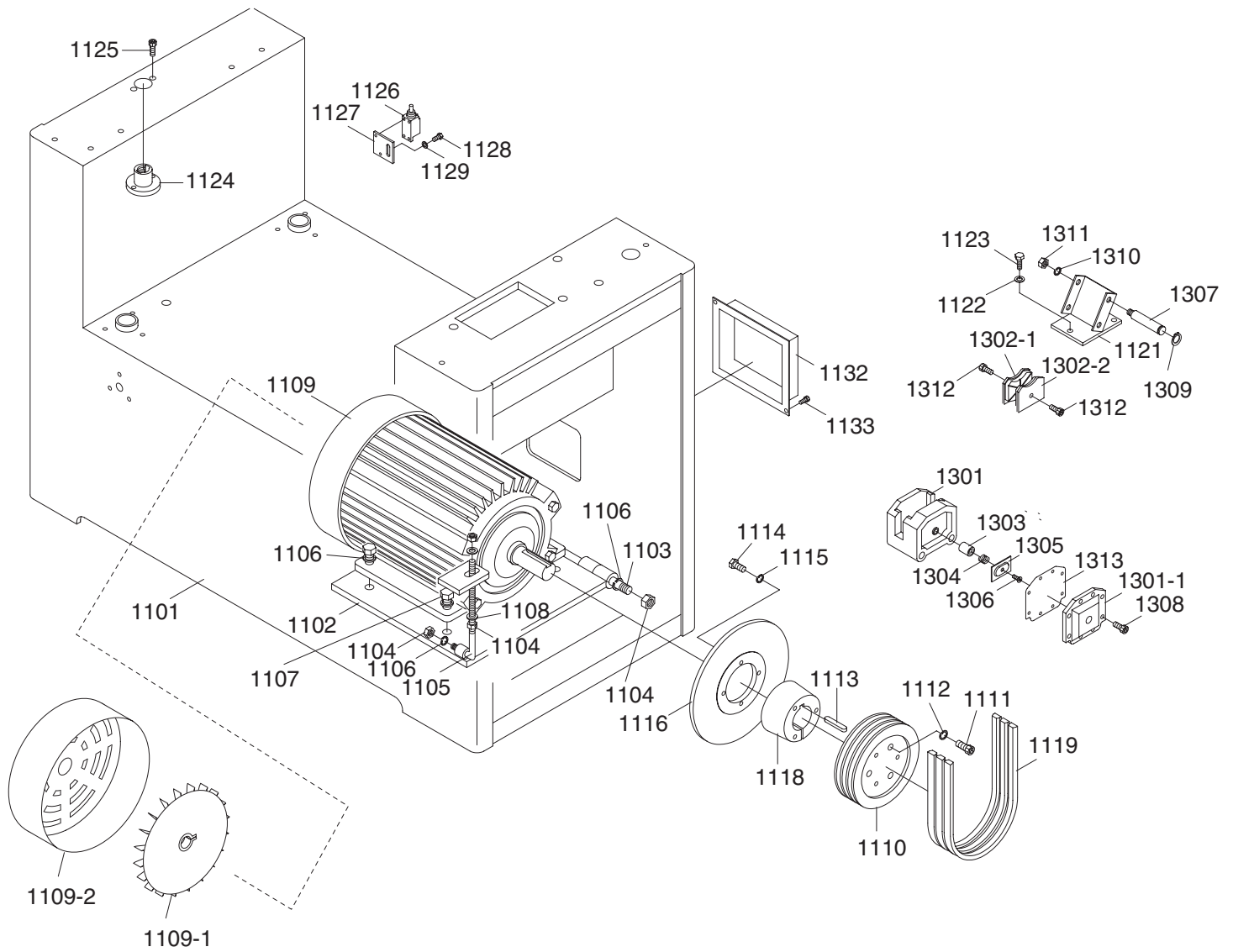

# Sanding Motor System Parts List

REF	PART #	DESCRIPTION
1101	P99791101	MACHINE FRAME (G9979)
1101	P99801101	MACHINE FRAME (G9980)
1102	P99791102	MOTOR BASE
1103	P99791103	MOTOR BASE HINGE
1104	PN06	HEX NUT 1/2-12
1105	P99791105	MOTOR BASE ADJUSTMENT ROD
1106	PLW07	LOCK WASHER 1/2
1107	PB40	HEX BOLT 1/2-12 X 1-1/4
1108	PW01	FLAT WASHER 1/2
1109	P99791109	MOTOR (G9979)
1109	P99801109	MOTOR (G9980)
1109-1	P99791109-1	FAN (G9979)
1109-1	P99801109-1	FAN (G9980)
1109-2	P99791109-2	FAN COVER (G9979)
1109-2	P99801109-2	FAN COVER (G9980)
1110	P99791110	PULLEY (G9979)
1110	P99801110	PULLEY (G9980)
1111	PSB11	CAP SCREW 5/16-18 X 1-1/4
1112	PLW01	LOCK WASHER 5/16
1113	P99791113	KEY 14 x 9 x 105MM
1114	PB03	HEX BOLT 5/16-18 X 1
1115	PLW01	LOCK WASHER 5/16
1116	P99791116	DISC BRAKE
1118	P99791118	PULLEY BUSHING
1119	PVB68	V-BELT B-68 5L680
1121	P99791121	BRAKE BRACKET

REF	PART #	DESCRIPTION
1122	PW02	FLAT WASHER 3/8
1123	PB21	HEX BOLT 3/8-16 X 3/4
1124	P99791124	THREADED HUB 5/8 X 11
1125	PSB05	CAP SCREW 1/4-20 X 3/4
1126	P99791126	LIMIT SWITCH
1127	P99791127	LIMIT SWITCH PLATE
1128	PB19	HEX BOLT 1/4-20 X 1/2
1129	PW06	FLAT WASHER 1/4
1132	P99791132	BACK COVER
1133	PB19	HEX BOLT 1/4-20 X 1/2
1301	P99791301	BRAKE BRACKET
1301-1	P99791301-1	BRAKE BRACKET FRONT GUARD
1301-2	P99791301-2	COMPLETE BRAKE LINING KIT
1302-1	P99791302-1	BRAKE LINING
1302-2	P99791302-2	BRAKE LINING
1303	P99791303	BRAKE ARBOR
1304	P99791304	BRAKE SPRING 3.3 X 24.5 X 24
1305	P99791305	BRAKE INSIDE PIECE
1306	PFH04	FLAT HD SCR 1/4-20 X 5/8
1307	P99791307	BRAKE PIN
1308	PSB31	CAP SCREW 10-24 X 5/8
1309	PR03M	EXT RETAINING RING 12MM
1310	PLW04	LOCK WASHER 3/8
1311	PN08	HEX NUT 3/8-16
1312	PSB04	CAP SCREW 1/4-20 X 1/2
1313	P99791313	BRAKE GASKET



# Table Lift System Diagram

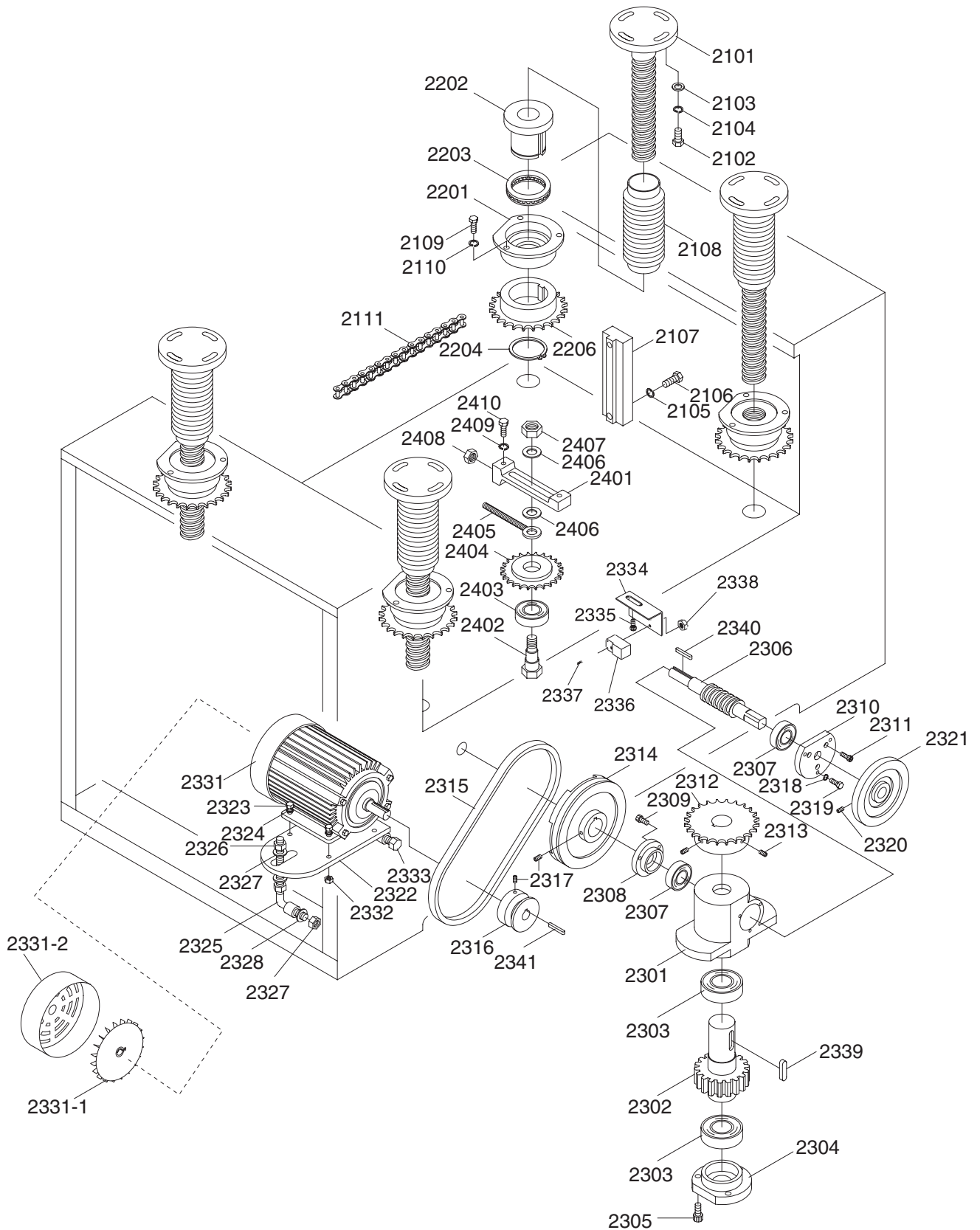

# Table Lift System Parts List

REF	PART #	DESCRIPTION
2101	P99792101	ELEVATION SCREW 1 X 5 X 280
2102	PB07	HEX BOLT 5/16-18 X 3/4
2103	PW07	FLAT WASHER 5/16
2104	PLW01	LOCK WASHER 5/16
2105	PLW04	LOCK WASHER 3/8
2106	PB18	HEX BOLT 3/8-16 X 1
2107	P99792107	ELEVATION SLIDE
2108	P99792108	DUST GUARD BELLOW
2109	PB07	HEX BOLT 5/16-18 X 3/4
2110	PLW01	LOCK WASHER 5/16
2111	P99792111	CHAIN (G9979)
2111	P99802111	CHAIN (G9980)
2201	P99792201	NUT HOUSING
2201-1	P99792201-1	NUT HOUSING ASSEMBLY
2202	P99792202	NUT 1 X 5
2203	P51107	THRUST BEARING 51107
2204	PR12M	EXT RETAINING RING 35MM
2206	P99792206	SPROCKET WHEEL
2301	P99792301	ELEVATION GEAR BOX
2302	P99792302	WORM GEAR
2303	P6005	BALL BEARING 6005ZZ
2304	P99792304	BEARING CAP
2305	PSB05	CAP SCREW 1/4-20 X 3/4
2306	P99792306	WORM
2307	P6002	BALL BEARING 6002ZZ
2308	P99792308	BEARING CAP
2309	PSB31	CAP SCREW 10-24 X 5/8
2310	P99792310	BEARING CAP
2311	PSB01	CAP SCREW 1/4-20 X 5/8
2312	P99792312	SPROCKET WHEEL
2313	PSS07	SET SCREW 1/4-20 X 1/2
2314	P99792314	PULLEY
2315	PVA34	V-BELT A-34 4L340

REF	PART #	DESCRIPTION
2316	P99792316	PULLEY
2317	PSS07	SET SCREW 1/4-20 X 1/2
2318	PLW01	LOCK WASHER 5/16
2319	PB07	HEX BOLT 5/16-18 X 3/4
2320	PSS06	SET SCREW 1/4-20 X 3/4
2321	P99792321	HAND WHEEL
2322	P99792322	MOTOR BASE
2323	PB31	HEX BOLT 1/4-20 X 1
2324	PLW02	LOCK WASHER 1/4
2325	P99792325	MOTOR BASE ADJUSTMENT ROD
2326	PW01	FLAT WASHER 1/2
2327	PW01	FLAT WASHER 1/2
2328	PLW07	LOCK WASHER 1/2
2331	P99792331	MOTOR
2332	PN05	HEX NUT 1/4-20
2333	P99792333	HEX BOLT 1/2-12 X 4-1/2
2334	P99792334	PROXIMITY SWITCH PLATE
2335	P99792335	SCREW 1/4-20 X 3/4
2336	P99792336	PROXIMITY SWITCH
2339	PK14	KEY 5/16 X 5/16 X 3/4
2340	PK48M	KEY 4 X 4 X 20
2341	PK37M	KEY 4 X 4 X 16
2401	P99792401	ADJUSTMENT PIECE
2402	P99792402	SPROCKET WHEEL SHAFT
2403	P6003	BALL BEARING 6003ZZ
2404	P99792404	ADJUSTMENT SPROCKET WHEEL
2405	P99792405	ADJUSTMENT ROD
2406	PW02	FLAT WASHER 3/8
2407	PN08	HEX NUT 3/8-16
2408	PN02	HEX NUT 5/16-18
2409	PLW01	LOCK WASHER 5/16
2410	PB07	HEX BOLT 5/16-18 X 3/4



# Conveyor System Diagram

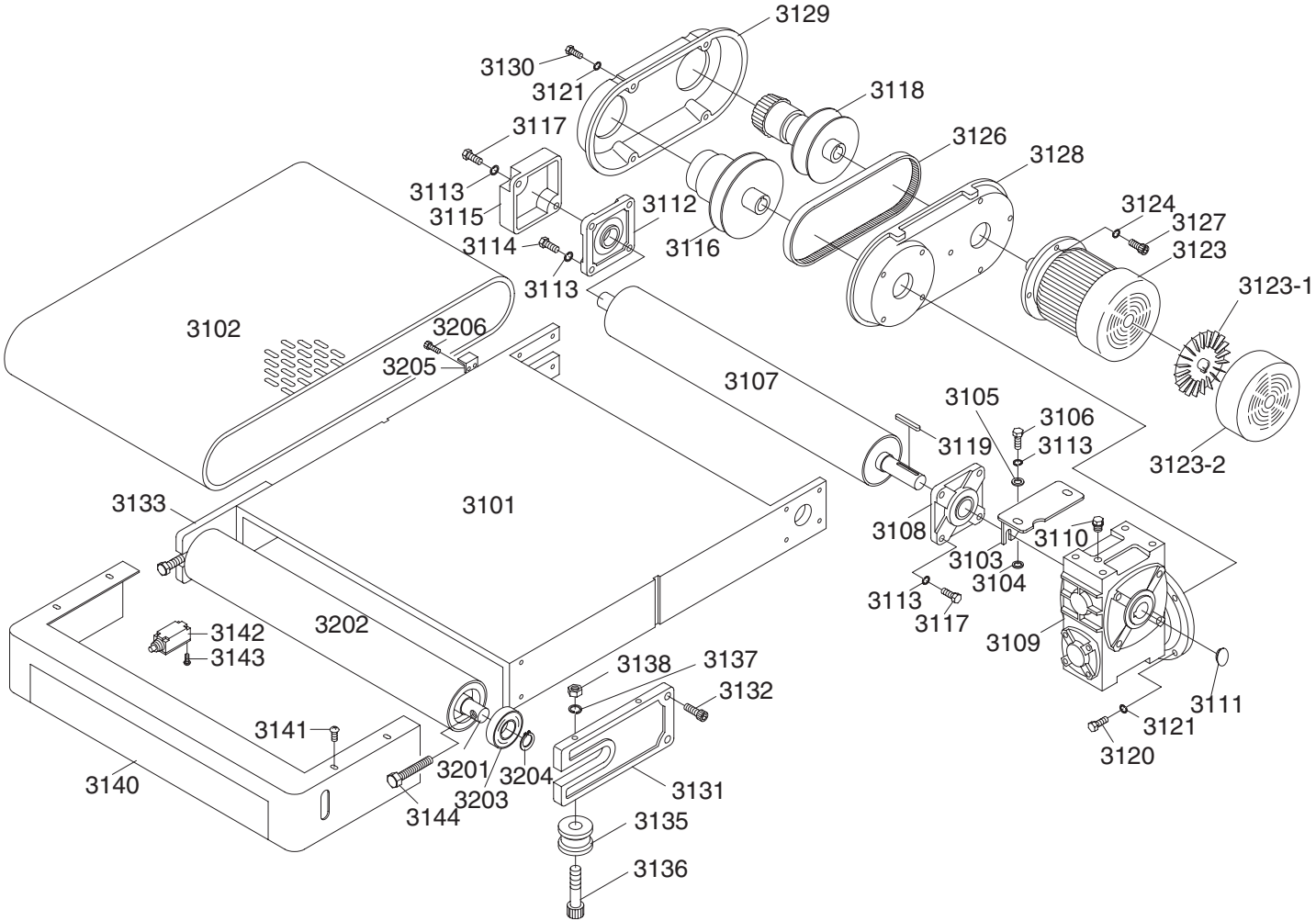

# Conveyor System Parts List

REF	PART #	DESCRIPTION
3101	P99793101	CONVEYOR TABLE (G9979)
3101	P99803101	CONVEYOR TABLE (G9980)
3102	P99793102	CONVEYOR BELT (G9979)
3102	P99803102	CONVEYOR BELT (G9980)
3103	P99793103	GEARBOX FIX PLATE
3104	P99793104	CUSHION
3105	PW02	FLAT WASHER 3/8
3106	PB18	HEX BOLT 3/8-16 X 1
3107	P99793107	OUTFEED ROLLER (G9979)
3107	P99803107	OUTFEED ROLLER (G9980)
3108	PUCF205	BALL BEARING UCF205
3109	P99793109	REDUCER
3110	P99793110	PLUG
3111	P99793111	PLUG
3112	PUCF205	BALL BEARING UCF205
3113	PLW04	LOCK WASHER 3/8
3114	PB24	HEX BOLT 3/8-16 X 1-1/4
3115	P99793115	BEARING CAP
3116	P99793116	DRIVEN PULLEY
3117	PB16	HEX BOLT 3/8-16 X 1-1/2
3118	P99793118	DRIVING PULLEY
3119	PK66M	KEY 7 X 7 X 55
3120	PB07M	HEX BOLT M8-1.25 X 25
3121	PLW04M	LOCK WASHER 8MM
3123	P99793123	MOTOR (G9979)
3123	P99803123	MOTOR (G9980)
3123-1	P99793123-1	FAN (G9979)
3123-1	P99803123-1	FAN (G9980)
3123-2	P99793123-2	FAN COVER (G9979)

REF	PART #	DESCRIPTION
3123-2	P99803123-2	FAN COVER (G9980)
3124	PLW06	LOCK WASHER 5/8
3126	P99793126	TIMING BELT 1422V-290
3127	PSB64M	CAP SCREW M10-1.5 X 25
3128	P99793128	BASE PLATE
3129	P99793129	VARIABLE SPEED UNIT COVER
3130	PSS21M	SET SCREW M8-1.25 X 25
3131	P99793131	INFEED ROLLER BRACKET
3132	PSB33	CAP SCREW 10-24 x 3/4
3133	P99793133	INFEED ROLLER BRACKET
3135	P99793135	POSITIONING WHEEL
3136	PSB70	CAP SCREW 5/16-18 X 2
3137	PLW01	LOCK WASHER 5/16
3138	PN02	HEX NUT 5/16-18
3140	P99793140	FRONT BRAKE COVER (G9979)
3140	P99803140	FRONT BRAKE COVER (G9980)
3141	PS04	PHLP HD SCR 1/4-20 X 1/2
3142	P99793142	LIMIT SWITCH
3143	PS10	PHLP HD SCR 10-24 x 1 1/2
3144	P99793144	CONVEYOR BELT ADJUST. ROD
3201	P99793201	INFEED ROLLER SHAFT (G9979)
3201	P99803201	INFEED ROLLER SHAFT (G9980)
3202	P99793202	INFEED ROLLER (G9979)
3202	P99803202	INFEED ROLLER (G9980)
3203	P6206	BALL BEARING 6206ZZ
3204	PR15M	EXT RETAINING RING 30MM
3205	P99793205	ELEVATION ALUMINUM LIMITER
3206	PSB62	CAP SCREW 1/4-20 X 1-1/2



# Feed, Drum, and Pressure Roller Diagram

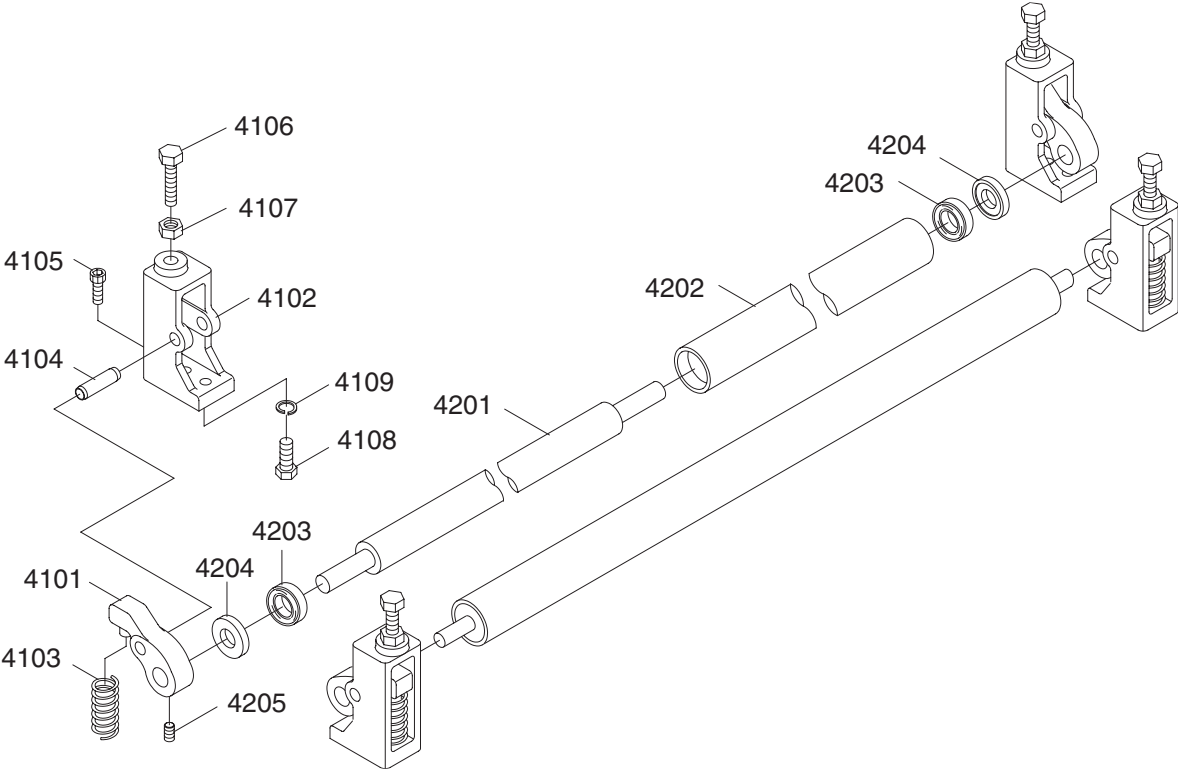

# Feed, Drum, and Pressure Roller Parts List

REF	PART #	DESCRIPTION
4101	P99794101	PISTON SLIDERAIL (G9979)
4101	P99804101	PISTON SLIDERAIL (G9980)
4102	P99794102	PISTON BRACKET
4103	P99794103	SPRING 3 X 15.6 X 57
4104	P99794104	PIN 10M/M X 35M/M
4105	PSB04	CAP SCREW 1/4-20 X 1/2
4106	PB11	HEX BOLT 5/16-18 X 1-1/2
4107	PN02	HEX NUT 5/16-18
4108	PB12	HEX BOLT 5/16-18 X 1-1/4

REF	PART #	DESCRIPTION
4109	PLW01	LOCK WASHER 5/16
4201	P99794201	PISTON ROLLER SHAFT (G9979)
4201	P99804201	PISTON ROLLER SHAFT (G9980)
4202	P99794202	PISTON ROLLER (G9979)
4202	P99804202	PISTON ROLLER (G9980)
4203	P6001	BALL BEARING 6001ZZ
4204	P99794204	SHAFT BEARING COLLER
4205	PSS03	SET SCREW 1/4-20 X 3/8





# Sanding Drum, and Platen System Parts List

REF	PART #	DESCRIPTION
5101	P99795101	BEARING HOUSING
5102	P99795102	RUBBER ROLLER (G9979)
5102	P99805102	RUBBER ROLLER (G9980)
5103	P99795103	FASTENING TUBE
5104	P99625104	BEARING UCC206
5105	P99795105	PULLEY
5106	PSB11	CAP SCREW 5/16-18 X 1-1/4
5107	PK11	KEY 5/16 X 5/16 X 1 3/16
5108	PLW01	LOCK WASHER 5/16
5109	P6205	BALL BEARING 6205ZZ
5110	PLW07	LOCK WASHER 1/2
5111	PSB76	CAP SCREW 1/2-12 X 1-1/2
5112	PSB04	CAP SCREW 1/4-20 X 1/2
5113	P99795113	BEARING CAP
5114	P99795114	FILTER
5116	P99795116	PLUG
5117	P99795117	COVER OF PULLEY
5118	PS04	PHLP HD SCR 1/4-20 X 1/2
5119	P99795119	SPANNER NUT
5201	P99795201	BEARING HOUSING
5202	P99795202	STEEL ROLLER (G9979)
5202	P99805202	STEEL ROLLER (G9980)
5203	PSS01M	SET SCREW M6-1 X 10
5204	P99625204	BEARING UCC205
5205	P99795205	HANDLE
5206	P99795206	FLAT HEAD SCREW 5/8 X 11
5211	P99795211	BEARING BRACKET PAD
5301	P99795301	BRACKET (MALE) (G9979)
5301	P99805301	BRACKET (MALE) (G9980)
5302	P99795302	BRACKET (FEMALE) (G9979)

REF	PART #	DESCRIPTION
5302	P99805302	BRACKET (FEMALE) (G9980)
5303	P99795303	FELT PAD (G9979)
5303	P99805303	FELT PAD (G9980)
5304	P99795304	GRAPHITE PAD (G9979)
5304	P99805304	GRAPHITE PAD (G9980)
5305	PS01	PHLP HD SCR 10-24 X 1/2
5306	P99795306	PRESSURE PLATE (G9979)
5306	P99805306	PRESSURE PLATE (G9980)
5307	P99795307	BASE
5308	P99795308	SHAFT (G9979)
5308	P99805308	SHAFT (G9980)
5309	P99795309	FASTENING TUBE (G9979)
5309	P99805309	FASTENING TUBE (G9980)
5310	PSS11	SET SCREW 1/4-20 X 1/4
5311	P99625311	SET SCREW 1/4-20 X 1
5312	P99795312	SPRING 3.5 X 21 X 65
5313	P99795313	HOUSING (G9979)
5313	P99805313	HOUSING (G9980)
5314	P99795314	SHAFT (G9979)
5314	P99805314	SHAFT (G9980)
5315	PSB16	CAP SCREW 3/8-16 X 3/4
5316	PW02	FLAT WASHER 3/8
5317	P99795317	WASHER 3/8 X 38 X 10
5318	P99795318	HANDLE
5319	PSS08	SET SCREW 5/16-18 X 1/2
5320	P99795320	RING FOR ADJUSTMENT
5321	PB03	HEX BOLT 5/16-18 X 1
5322	PW07	FLAT WASHER 5/16
5323	P99795323	HANDLE



# Upper Roller System Diagram

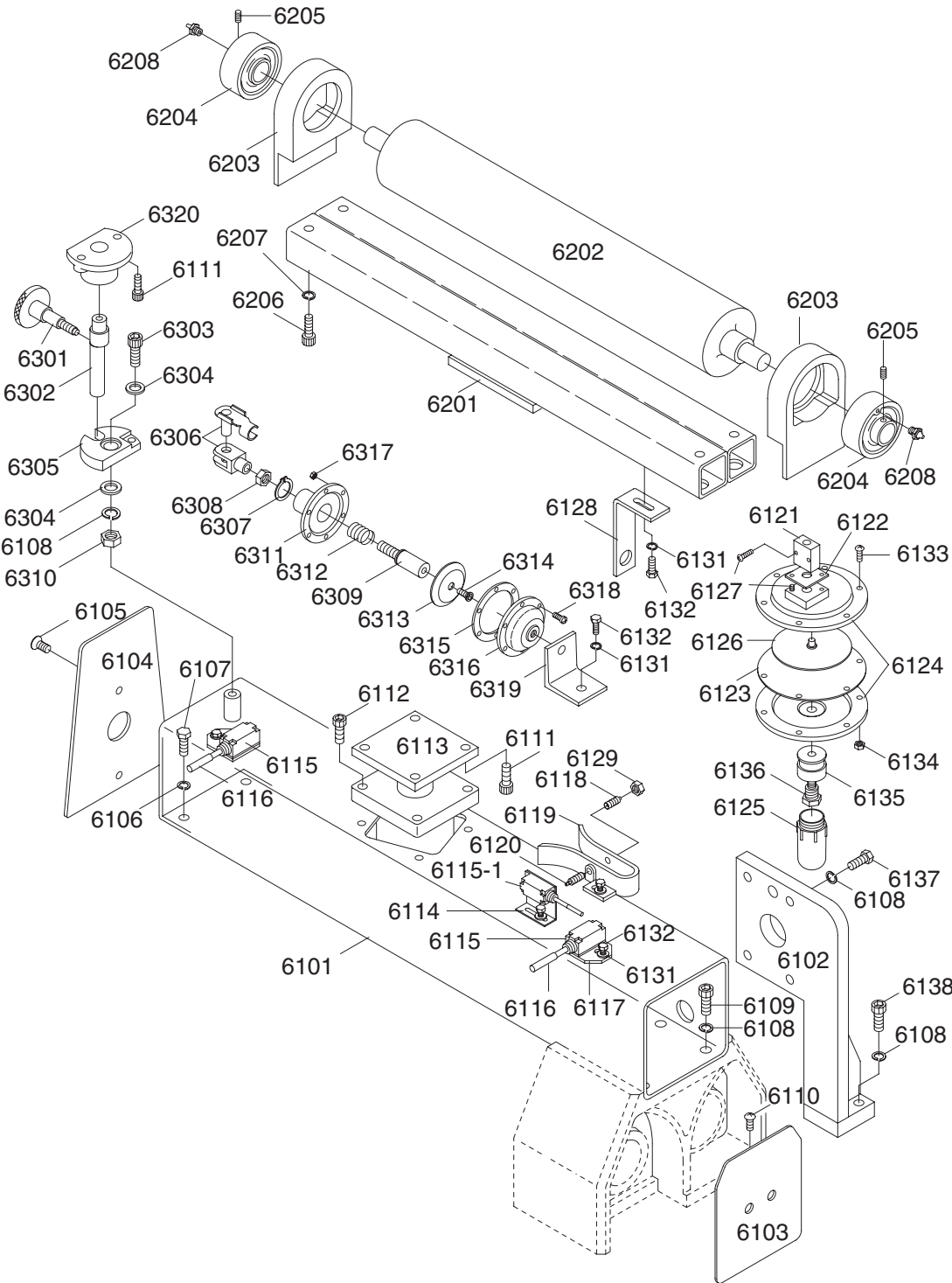

# Upper Roller System Parts List

REF	PART #	DESCRIPTION
6101	P99796101	SQUARE FRAME (G9979)
6101	P99806101	SQUARE FRAME (G9980)
6102	P99796102	SUPPORTING FRAME
6103	P99796103	SQUARE FRAME SEAL (RIGHT)
6104	P99796104	SQUARE FRAME SEAL (LEFT)
6105	PFH03	FLAT HD SCR 1/4-20 X 1/2
6106	PLW04	LOCK WASHER 3/8
6107	PB18	HEX BOLT 3/8-16 X 1
6108	PLW07	LOCK WASHER 1/2
6109	PSB76	CAP SCREW 1/2-12 X 1-1/2
6111	PSB07	CAP SCREW 5/16-18 X 3/4
6112	PSB03	CAP SCREW 5/16-18 X 1
6113	P99796113	AIR CYLINDER
6114	P99796114	LIMIT SWITCH HOLDER (L TYPE)
6115	P9962Z6115	LIMIT SWITCH WITH CERAMIC TIP
6115-1	P99796115-1	LIMIT SWITCH WITH PLASTIC TIP
6116	P99796116	LIMIT SWITCH POST
6117	P99796117	LIMIT SWITCH HOLDER
6118	P99796118	AIR SENSOR NOZZLE (FEMALE)
6119	P99796119	AIR CYLINDER BRACKET
6120	P99796120	AIR SENSOR NOZZLE (MALE)
6121	P99796121	THROTTLE VALVE
6122	P99796122	THROTTLE VALVE BASE
6123	P99796123	PLATE
6124	P99796124	ALUMINUM DISC
6125	P99796125	OIL CAP
6126	P99796126	ALUMINUM PLATE
6127	PS52M	PHLP HD SCR M4-.7 X 20
6128	P99796128	POWER OFF PLATE
6129	PN11	HEX NUT 3/8-24
6131	PLW01	LOCK WASHER 5/16
6132	PB09	HEX BOLT 5/16-18 X 1/2
6133	PS08	PHLP HD SCR 10-24 X 3/4
6134	PN07	HEX NUT 10-24

REF	PART #	DESCRIPTION
6135	P99796135	OIL CAP CONNECTOR
6136	P99796136	SHAFT OF OIL CAP
6137	PB53	HEX BOLT 1/2-12 X 1
6138	PSB76	CAP SCREW 1/2-12 X 1-1/2
6201	P99796201	ROLLER BRACKET (G9979)
6201	P99806201	ROLLER BRACKET (G9980)
6202	P99796202	ROLLER (G9979)
6202	P99806202	ROLLER (G9980)
6203	P99796203	UPPER ROLLER BRACKET
6204	P99625204	BEARING UCC205
6205	PSS02M	SET SCREW M6-1 X 6
6206	PSB33	CAP SCREW 10-24 x 3/4
6207	PLW04	LOCK WASHER 3/8
6208	P99796208	FILTER
6301	P99796301	TRIMMING SCREW 2 X 90MM
6302	P99796302	ECCENTRIC ROD
6303	PSB79	CAP SCREW 1/2-12 X 3-1/2
6304	PW01	FLAT WASHER 1/2
6305	P99796305	ECCENTRIC PIECE
6306	P99796306	UNIVERSAL JOINT FORK
6307	PR05M	EXT RETAINING RING 15MM
6308	PN27M	HEX NUT M10-1.5 (LH)
6309	P99796309	SHAFT OF AIR CYLINDER
6310	PN06	HEX NUT 1/2-12
6311	P99796311	BOTTOM COVER
6312	P99796312	COMPRESSION SPRING
6313	P99796313	ALUMINUM PLATE
6314	PFH02M	FLAT HD SCR M6-1 X 12
6315	P99796315	PLATE
6316	P99796316	TOP COVER
6317	PN07	HEX NUT 10-24
6318	PS08	PHLP HD SCR 10-24 X 3/4
6319	P99796319	AIR CYLINDER FIRING BASE
6320	P99796320	FRAME OF ECCENTRIC SHAFT



# Cabinet Assembly Diagram

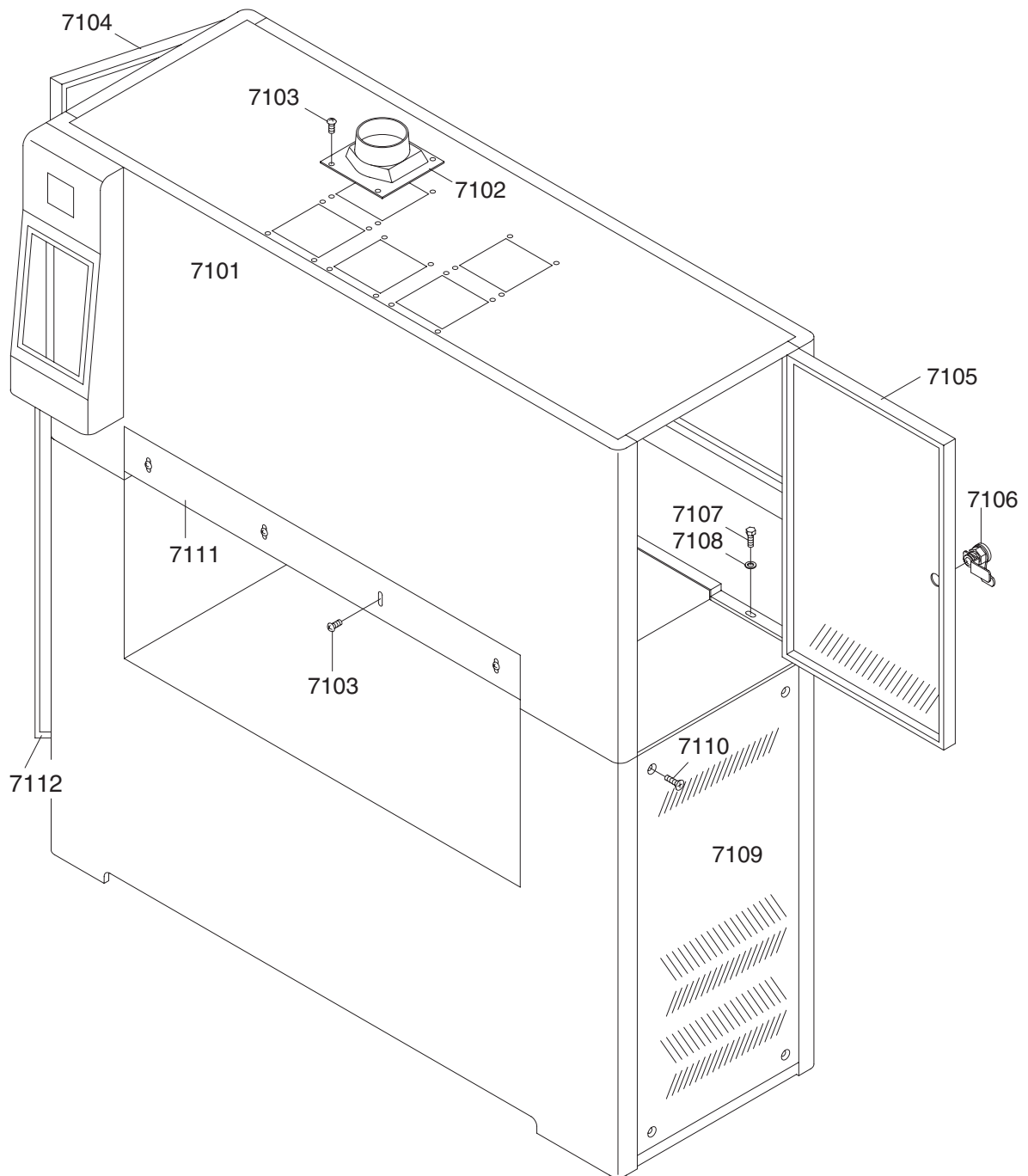

# Cabinet Assembly Parts List

REF	PART #	DESCRIPTION
7101	P99797101	UPPER FRAME COVER (G9979)
7101	P99807101	UPPER FRAME COVER (G9980)
7102	P99797102	DUST PORT
7103	PS14M	PHLP HD SCR M6-1 X 12
7104	P99797104	LEFT DOOR, UPPER FRAME
7105	P99797105	RIGHT DOOR, UPPER FRAME
7106	P99797106	DOOR LOCK

REF	PART #	DESCRIPTION
7107	PB07	HEX BOLT 5/16-18 X 3/4
7108	PW07	FLAT WASHER 5/16
7109	P99797109	RIGHT DOOR, LOWER FRAME
7110	PFH03	FLAT HD SCR 1/4-20 X 1/2
7111	P99797111	PROTECTION PLATE (G9979)
7111	P99807111	PROTECTION PLATE (G9980)
7112	P99797112	LEFT DOOR, LOWER FRAME



# Main Electrical Panel and Controls Diagram

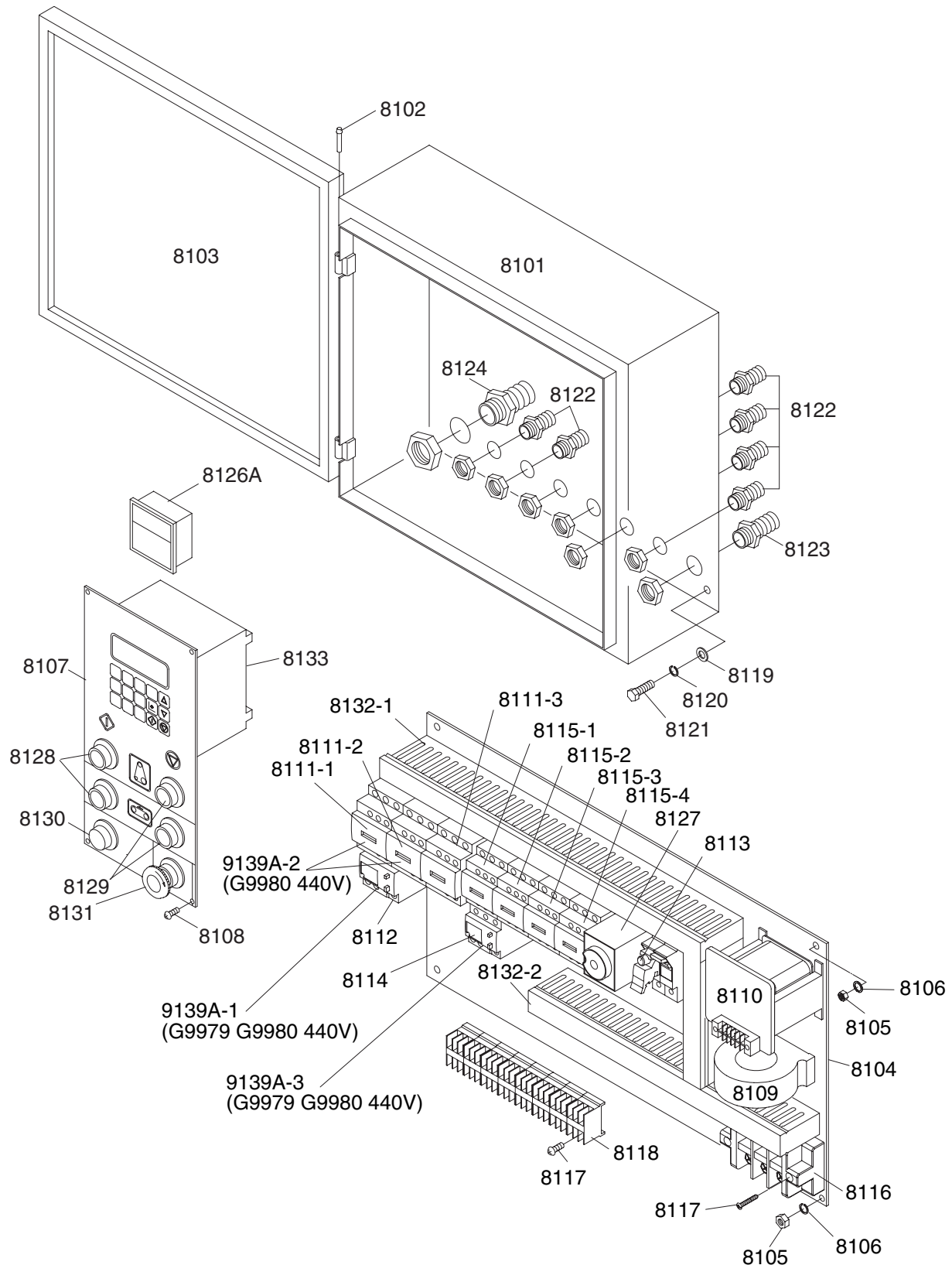

# Main Electrical Panel and Controls Parts List

REF	PART #	DESCRIPTION
8101	P99798101	ELECTRICAL BOX
8102	P99798102	HINGE
8103	P99798103	DOOR
8104	P99798104	BASE PLATE
8105	PN05	HEX NUT 1/4-20
8106	PLW02	LOCK WASHER 1/4
8107	P99798107	CONTROL PANEL
8108	PS07M	PHLP HD SCR M4-.7 X 8
8109	P99798109	CURRENT SENSOR
8110	P99798110	TRANSFORMER
8111	P99798111	MAGNETIC CONTACTOR
8111-1	P99798111-1	MAGNETIC CONTACTOR LC1-D386 (G9979)
8111-1	P99808111-1	MAGNETIC CONTACTOR LCI-D40 (G9980)
8111-2	P99798111-2	MAGNETIC CONTACTOR LC1-D386 (G9979)
8111-2	P99808111-2	MAGNETIC CONTACTOR LCI-D40 (G9980)
8111-3	P99798111-3	MAGNETIC CONTACTOR LC1-D326 (G9979)
8111-3	P99780111-3	MAGNETIC CONTACTOR LC1-D386 (G9980)
8112	P99798112	OVERLOAD RELAY LR3D-356 (30-38A) 220V 32A (G9979)
8112	P99808112	OVERLOAD RELAY LR3D-3355 (30-40A) 220V 36A (G9980)
8113	P99798113	4A FUSE (WITH HOUSING)

REF	PART #	DESCRIPTION
8114	P99798114	OVERLOAD RELAY LR3D-126 (5.5-8A) 220V 6A (G9979 G9980)
8115-1	P99798115-1	MAGNETIC CONTACTOR LC1-D096
8115-2	P99798115-2	MAGNETIC CONTACTOR LC1-096(W/LOCK)
8115-3	P99798115-3	MAGNETIC CONTACTOR LC1-096(W/LOCK)
8115-4	P99798115-4	MAGNETIC CONTACTOR LC1-D096
8116	P99798116	POWER WIRE TERMINAL
8117	PS51M	PHLP HD SCR M4-.7 X 30
8118	P99798118	TERMINAL PLATE
8119	PW07	FLAT WASHER 5/16
8120	PLW01	LOCK WASHER 5/16
8121	PB19	HEX BOLT 1/4-20 X 1/2
8122	P99798122	PU CONNECTOR 1/2"
8123	P99798123	PU CONNECTOR 3/4"
8124	P99798124	CABLE CONNECTOR 1"
8126A	P99798126A	DIGITALAMP METER
8127	P99798127	START TIMER
8128	P99798128	START SWITCH
8129	P99798129	STOP SWITCH
8130	P99798130	POWER INDICATION LIGHT
8131	P99798131	EMERGENCY STOP SWITCH
8132-1	P99798132-1	WIRE COLUMN
8132-2	P99798132-2	WIRE COLUMN
8133	P99798133	COMPUTER

## G9979 440V CONVERSION KIT

9139A	P99809139A	COMPLETE 440V CONVERSION KIT (G9979)
9139A-1	P99799139A-1	THERMAL RELAY LR3D-216 (12-18A) 440V 16A (G9979)
9139A-3	P99799139A-3	THERMAL RELAY LR3D-086 (2.5-6A) 440V 3A (G9979)

## G9980 440V CONVERSION KIT

9139A	P99809139-A	COMPLETE 440V CONVERSION KIT (G9980)
9139A-1	P99809139A-1	THERMAL RELAY LR3D-226 (16-24A) 440V 18A (G9980)
9139A-2	P99809139A-2	CONTACTOR (SET OF TWO) LC1-D386 440V (G9980)
9139A-3	P99809139A-3	THERMAL RELAY LR3D-086 (2.5-4A) 440V 3A (G9980)





# Belt Oscillation System Parts List

REF	PART #	DESCRIPTION
9101	P99799101	FILTER CUP
9102	P99799102	PRESSURE REGULATOR
9103	P99799103	BRONZE CONNECTOR
9104	P99799104	FLEXIBLE HOSE
9105	P99799105	AIR SWITCH
9106	P99799106	ELBOW
9107	PS22	PHLP HD SCR 10-24 x 5/8
9108	PH29339108	ELBOW 5/16N X1/8T 90°
9109	P99799109	SOLENOID VALVE
9110	PH29339110	T-FITTING 5/16N X 5/16N X 1/8T
9111	PH29339111	CONNECTOR
9112	PH29339112	MANIFOLD 1/4N
9113	PH29339113	CONNECTOR 5/16N X1/8T
9114	PH29339114	ELBOW 1/4N X 1/4N 90°
9115	PH29339115	CONNECTOR 1/4N X1/8T 90°
9116	PH29339116	CONNECTOR 1/4N X1/8T 90°
9117	P99799117	THROTTLE VALVE
9118	P99799118	BRASS CONNECTOR
9119	PH29339119	CONNECTOR 1/4N X1/8T

REF	PART #	DESCRIPTION
9120	PH29339120	CONNECTOR 3/8N X1/8T
9121	PH29339121	CONNECTOR 1/4N X1/8T
9122	P99799122	AIR SWITCH
9123	PH29339123	CONNECTOR 1/4N X1/8T
9124	PH29339124	CONNECTOR 1/4N X1/8T 90°
9125	P99799125	BUFFER
9126	P99799126	MULTIPLE HOLE CONNECTOR
9127	PH29339127	CONNECTOR 5/16N X 1/8T 90°
9128	P99799128	8MM FLEXIBLE HOSE
9129	P99799129	6MM FLEXIBLE HOSE
9130	P99799130	6MM FLEXIBLE HOSE
9131	P99799131	6MM FLEXIBLE HOSE
9132	P99799132	6MM FLEXIBLE HOSE
9133	P99799133	6MM FLEXIBLE HOSE
9134	P99799134	6MM FLEXIBLE HOSE
9135	P99799135	6MM FLEXIBLE HOSE
9136	P99799136	6MM FLEXIBLE HOSE
9137	P99799137	6MM FLEXIBLE HOSE
9138	P99799138	6MM FLEXIBLE HOSE



# WARRANTY & RETURNS

---

---

Grizzly Industrial, Inc. warrants every product it sells for a period of **1 year** to the original purchaser from the date of purchase. This warranty does not apply to defects due directly or indirectly to misuse, abuse, negligence, accidents, repairs or alterations or lack of maintenance. This is Grizzly's sole written warranty and any and all warranties that may be implied by law, including any merchantability or fitness, for any particular purpose, are hereby limited to the duration of this written warranty. We do not warrant or represent that the merchandise complies with the provisions of any law or acts unless the manufacturer so warrants. In no event shall Grizzly's liability under this warranty exceed the purchase price paid for the product and any legal actions brought against Grizzly shall be tried in the State of Washington, County of Whatcom.

We shall in no event be liable for death, injuries to persons or property or for incidental, contingent, special, or consequential damages arising from the use of our products.

To take advantage of this warranty, contact us by mail or phone and give us all the details. We will then issue you a "Return Number," which must be clearly posted on the outside as well as the inside of the carton. We will not accept any item back without this number. Proof of purchase must accompany the merchandise.

The manufacturers reserve the right to change specifications at any time because they constantly strive to achieve better quality equipment. We make every effort to ensure that our products meet high quality and durability standards and we hope you never need to use this warranty.

Please feel free to write or call us if you have any questions about the machine or the manual.

Thank you again for your business and continued support. We hope to serve you again soon.





# WARRANTY CARD

Name \_\_\_\_\_

Street \_\_\_\_\_

City \_\_\_\_\_ State \_\_\_\_\_ Zip \_\_\_\_\_

Phone # \_\_\_\_\_ Email \_\_\_\_\_ Invoice # \_\_\_\_\_

Model # \_\_\_\_\_ Order # \_\_\_\_\_ Serial # \_\_\_\_\_

The following information is given on a voluntary basis. It will be used for marketing purposes to help us develop better products and services. **Of course, all information is strictly confidential.**

1. How did you learn about us?

- Advertisement
- Card Deck
- Friend
- Website
- Catalog
- Other:

2. Which of the following magazines do you subscribe to?

- |   |  |   |
|---|--|---|
| <input type="checkbox"/> Cabinet Maker          | <input type="checkbox"/> Popular Mechanics   | <input type="checkbox"/> Today's Homeowner    |
| <input type="checkbox"/> Family Handyman        | <input type="checkbox"/> Popular Science     | <input type="checkbox"/> Wood                 |
| <input type="checkbox"/> Hand Loader            | <input type="checkbox"/> Popular Woodworking | <input type="checkbox"/> Wooden Boat          |
| <input type="checkbox"/> Handy                  | <input type="checkbox"/> Practical Homeowner | <input type="checkbox"/> Woodshop News        |
| <input type="checkbox"/> Home Shop Machinist    | <input type="checkbox"/> Precision Shooter   | <input type="checkbox"/> Woodsmith            |
| <input type="checkbox"/> Journal of Light Cont. | <input type="checkbox"/> Projects in Metal   | <input type="checkbox"/> Woodwork             |
| <input type="checkbox"/> Live Steam             | <input type="checkbox"/> RC Modeler          | <input type="checkbox"/> Woodworker West      |
| <input type="checkbox"/> Model Airplane News    | <input type="checkbox"/> Rifle               | <input type="checkbox"/> Woodworker's Journal |
| <input type="checkbox"/> Modeltec               | <input type="checkbox"/> Shop Notes          | <input type="checkbox"/> Other:               |
| <input type="checkbox"/> Old House Journal      | <input type="checkbox"/> Shotgun News        |   |

3. What is your annual household income?

- \$20,000-\$29,000
- \$30,000-\$39,000
- \$40,000-\$49,000
- \$50,000-\$59,000
- \$60,000-\$69,000
- \$70,000+

4. What is your age group?

- 20-29
- 30-39
- 40-49
- 50-59
- 60-69
- 70+

5. How long have you been a woodworker/metalworker?

- 0-2 Years
- 2-8 Years
- 8-20 Years
- 20+ Years

6. How many of your machines or tools are Grizzly?

- 0-2
- 3-5
- 6-9
- 10+

7. Do you think your machine represents a good value?  Yes  No

8. Would you recommend Grizzly Industrial to a friend?  Yes  No

9. Would you allow us to use your name as a reference for Grizzly customers in your area?  
Note: We never use names more than 3 times.  Yes  No

10. Comments: \_\_\_\_\_

\_\_\_\_\_

\_\_\_\_\_

\_\_\_\_\_

CUT ALONG DOTTED LINE

FOLD ALONG DOTTED LINE

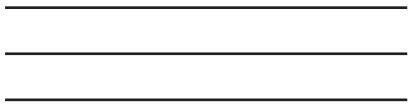

Place  
Stamp  
Here



GRIZZLY INDUSTRIAL, INC.  
P.O. BOX 2069  
BELLINGHAM, WA 98227-2069



FOLD ALONG DOTTED LINE

Send a Grizzly Catalog to a friend:

Name	_____
Street	_____
City	_____ State _____ Zip _____

TAPE ALONG EDGES--PLEASE DO NOT STAPLE



# *grizzly.com*

**TOOL WEBSITE**

Buy Direct and Save with Grizzly® – Trusted, Proven and a Great Value!

*Visit Our Website Today And Discover  
Why Grizzly® Is The Industry Leader!*

- SECURE ORDERING
- ORDERS SHIPPED WITHIN 24 HOURS
- E-MAIL RESPONSE WITHIN ONE HOUR

-OR-

Call Today For A **FREE**  
Full Color Catalog

**1-800-523-4777**

