



MODEL G8748 HAND TAPPING MACHINE INSTRUCTIONS

Introduction

The Model G8748 provides excellent alignment, control, and rigidity when tapping holes. As a result, tapping will be much easier and you will have fewer broken taps.

Inventory

A.	Fixed Jaw	1
B.	Lever	1
C.	Spindle	1
D.	Handle Assembly	1
E.	L-Frame.....	1
F.	Movable Jaw	1
G.	Counterbalance	1
H.	Base	1
I.	Adapter Rack.....	1
	—Adapter #6	1
	—Adapter #8	1
	—Adapter #10	1
	—Adapter 1/4"	1
	—Adapter 5/16"	1
	—Adapter 3/8"	1
	—Adapter 7/16"	1
	—Adapter 1/2"	1
	—Adapter 5/8"	1
J.	Hardware	
	—Knurled Knob	1
	—Cap Screws M10-1.5 x 35	4
	—Collar	1
	—Phillips Head Screws M5-.8 x 40.....	2
	—Thumbscrew	1
	—Dowel Pin 4 x 30mm	1
	—Taper Pin	1

Cleaning

Remove shipping grease from all coated parts with a mild solvent or degreaser, then re-coat them with a light layer of oil to prevent rust.



Figure 1. Model G8748 Hand Tapping Machine.

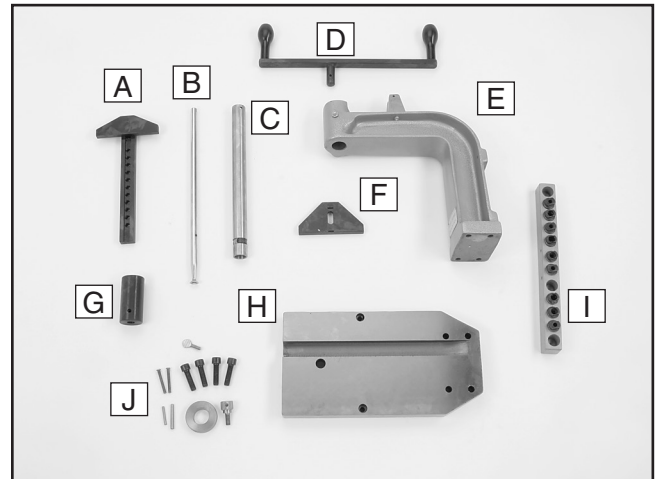

Figure 2. Model G8748 inventory.

Lubrication

After assembly, lubricate the grease fitting on the side of the L-frame with multi-purpose grease, then re-lubricate often to minimize wear and ease operation.

If you need help with your new item, call our Tech Support at: (570) 546-9663.

COPYRIGHT © APRIL, 2007 BY GRIZZLY INDUSTRIAL, INC.

WARNING: NO PORTION OF THIS MANUAL MAY BE REPRODUCED IN ANY SHAPE OR FORM WITHOUT THE WRITTEN APPROVAL OF GRIZZLY INDUSTRIAL, INC.

#TR9245 PRINTED IN CHINA

Assembly

1. Attach the L-frame to the base with four M10-1.5 x 35 cap screws, as shown in **Figure 3**.

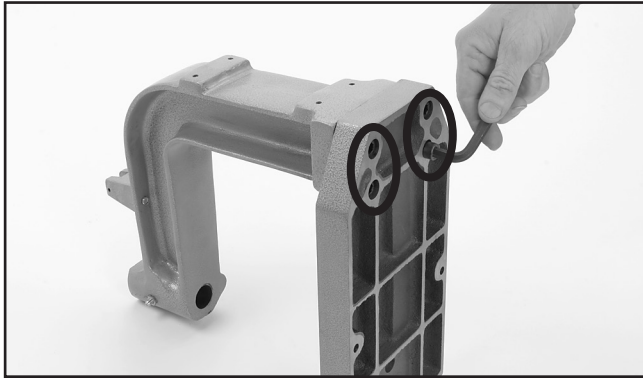

Figure 3. Attaching L-frame to base.

2. Slide the collar about halfway down the spindle, then tighten the collar set screw so the collar is secured to the spindle.
3. Slide the spindle into the L-frame as shown in **Figure 4**.

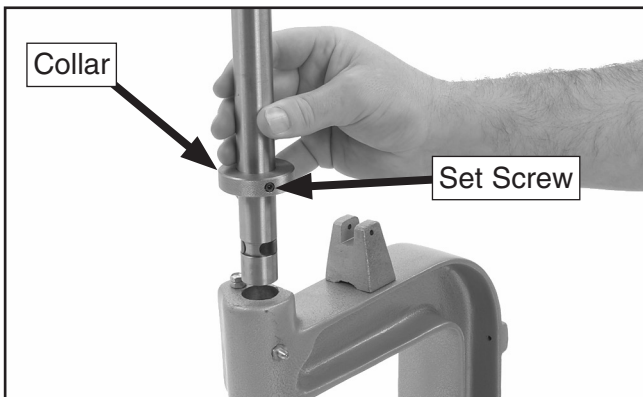

Figure 4. Sliding spindle into L-frame.

4. Insert the handle assembly into the top of the spindle, then slide the tapered pin through the spindle and into the handle assembly (**Figure 5**).

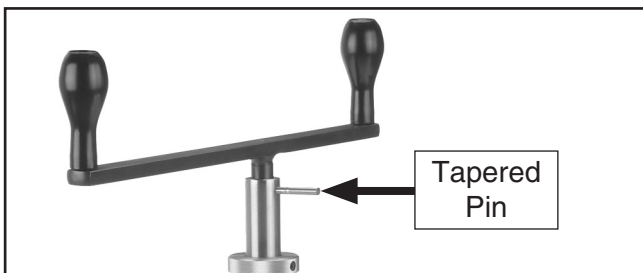

Figure 5. Handle assembly installed on spindle.

5. Slide the fixed jaw into the slot on the base and secure the movable jaw with the knurled knob, as shown in **Figure 6**.



Figure 6. Vise jaws installed on base.

6. Attach the lever to the lever bracket with the dowel pin, then slide the counterbalance onto the end of the lever and secure it with the thumbscrew (see **Figure 7**). *The counterbalance helps the spindle return to the up position out of the way of the workpiece.*

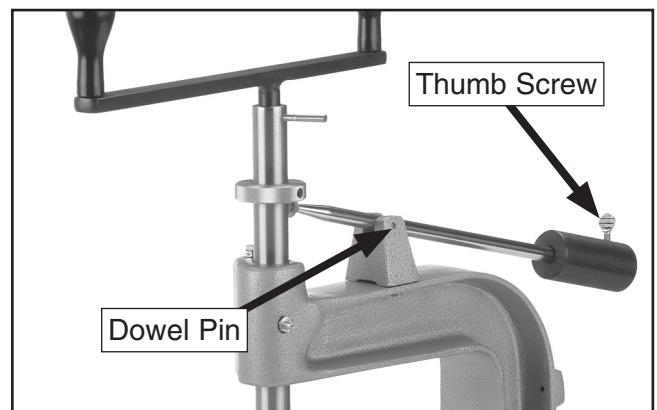

Figure 7. Lever and counterbalance installed.

7. Attach the adapter rack to the L-frame with the two M5-.8 x 40 Phillips head screws, as shown in **Figure 8**.

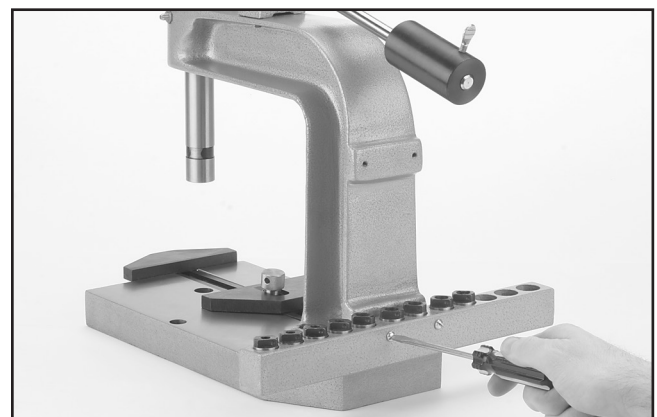

Figure 8. Attaching adapter rack to L-frame.



Operation

The biggest risk when tapping holes is breaking the tap. Since taps are hardened, they are also very brittle and can snap off in the workpiece if they are over-torqued. Chips may fly into the operator's eyes if a tap breaks, causing immediate eye injury. Also, broken taps can be very difficult to remove, often requiring a special tap extractor.



To prevent breaking taps, follow these tips:

- Drill a hole to the proper size for your tap (refer to the documentation included with your tap set or find a chart on the internet).
- Use tapping lubrication designed for the type of metal you are tapping.
- Don't force the tap deeper when rotation becomes stiff. Instead, back the tap out, clean off the cutting threads, re-lubricate, then start again.
- Be aware of the tapping hole depth. When the tap bottoms out in the hole, stop rotating it. Use the collar provided with the hand tapping machine as a depth stop.

To install a tap and prepare the hand tapping machine for operation:

1. Slide the tap into a matching sized adapter.
2. Tighten the set screw in the adapter against a flat surface on the tap shaft (see **Figure 9**).



Figure 9. Tap installed into adapter.

3. Insert the adapter into the spindle (**Figure 10**), then rotate the adapter until it snaps in place.

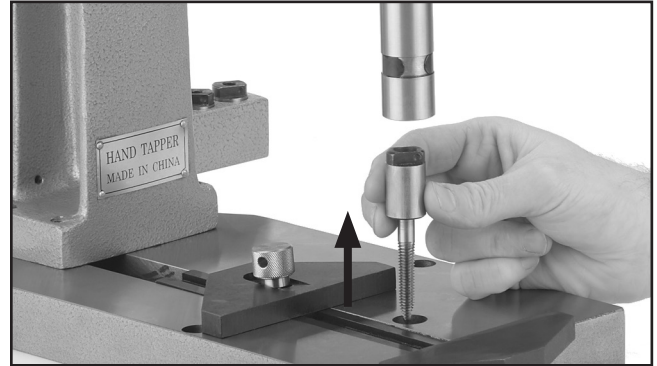

Figure 10. Inserting the adapter into the spindle.

4. Set the depth stop of the tap as follows: Position the spindle so the tap is at the desired stopping point, push the spindle collar down so the lever is against the L-frame, then tighten the spindle collar set screw, as shown in **Figure 11**.



Figure 11. Tightening spindle collar set screw.

5. Position the workpiece in the vise so the drilled hole is aligned with the tap, then secure the workpiece with the vise.

To remove an adapter:

1. Rotate the clip near the bottom end of the spindle until the detent ball is exposed.
2. Pull the adapter out.
3. Rotate the clip back over the detent ball to prepare the spindle for accepting another adapter.



G8748 Parts Breakdown and List

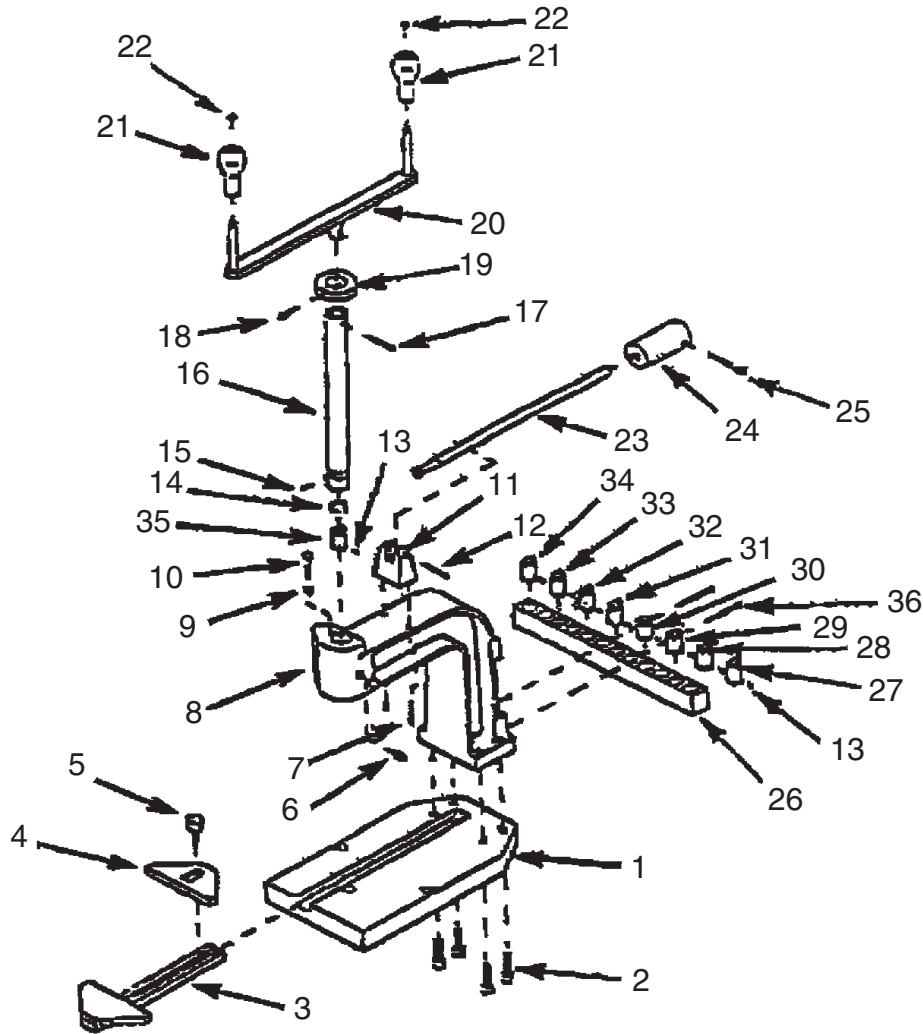

REF	PART #	DESCRIPTION
1	P8748001	BASE
2	PSB84M	CAP SCREW M10-1.5 X 35
3	P8748003	FIXED JAW
4	P8748004	MOVABLE JAW
5	P8748005	KNOB
6	P8748006	GREASE FITTING
7	PB95M	HEX BOLT M5-.8 X 16
8	P8748008	L-FRAME
9	PN06M	HEX NUT M5-.8
10	PB93M	HEX BOLT M5-.8 X 30
11	P8748011	LEVER BRACKET
12	P8748012	DOWEL PIN 4 X 30MM
13	PSS07M	SET SCREW M5-.8 X 5
14	P8748014	CLIP
15	P8748015	STEEL BALL 3/16
16	P8748016	SPINDLE
17	P8748017	TAPER PIN
18	PSS04M	SET SCREW M6-1 X 12

REF	PART #	DESCRIPTION
19	P8748019	COLLAR
20	P8748020	HANDLE
21	P8748021	KNOB
22	PR36M	EXT RETAINING RING 7MM
23	P8748023	LEVER
24	P8748024	COUNTERBALANCE
25	P8748025	THUMB SCREW
26	P8748026	ADAPTER RACK
27	P8748027	#6 ADAPTER
28	P8748028	#8 ADAPTER
29	P8748029	#10 ADAPTER
30	P8748030	1/4" ADAPTER
31	P8748031	5/16" ADAPTER
32	P8748032	3/8" ADAPTER
33	P8748033	7/16" ADAPTER
34	P8748034	1/2" ADAPTER
35	P8748035	5/8" ADAPTER
36	PS100M	PHLP HD SCR M5-.8 X 40

