

Grizzly **Industrial, Inc.**®

MODEL G7947 G7948 12-SPEED DRILL PRESSES

OWNER'S MANUAL

(For models manufactured since 01/21)



COPYRIGHT © AUGUST, 2005 BY GRIZZLY INDUSTRIAL, INC. REVISED JANUARY, 2021 (JL)
**WARNING: NO PORTION OF THIS MANUAL MAY BE REPRODUCED IN ANY SHAPE
OR FORM WITHOUT THE WRITTEN APPROVAL OF GRIZZLY INDUSTRIAL, INC.**

#TR7410 PRINTED IN CHINA

V3.01.21



WARNING!

This manual provides critical safety instructions on the proper setup, operation, maintenance, and service of this machine/tool. Save this document, refer to it often, and use it to instruct other operators.

Failure to read, understand and follow the instructions in this manual may result in fire or serious personal injury—including amputation, electrocution, or death.

The owner of this machine/tool is solely responsible for its safe use. This responsibility includes but is not limited to proper installation in a safe environment, personnel training and usage authorization, proper inspection and maintenance, manual availability and comprehension, application of safety devices, cutting/sanding/grinding tool integrity, and the usage of personal protective equipment.

The manufacturer will not be held liable for injury or property damage from negligence, improper training, machine modifications or misuse.



WARNING!

Some dust created by power sanding, sawing, grinding, drilling, and other construction activities contains chemicals known to the State of California to cause cancer, birth defects or other reproductive harm. Some examples of these chemicals are:

- **Lead from lead-based paints.**
- **Crystalline silica from bricks, cement and other masonry products.**
- **Arsenic and chromium from chemically-treated lumber.**

Your risk from these exposures varies, depending on how often you do this type of work. To reduce your exposure to these chemicals: Work in a well ventilated area, and work with approved safety equipment, such as those dust masks that are specially designed to filter out microscopic particles.

Table of Contents

INTRODUCTION	2	SECTION 5: ACCESSORIES	34
Contact Info.....	2	SECTION 6: MAINTENANCE	38
Machine Description	2	General	38
Manual Accuracy	2	Cleaning & Protecting	38
Identification.....	3	Lubrication	38
Controls & Components.....	4	V-Belts	38
G7947 Machine Data Sheet	5	SECTION 7: SERVICE	39
G7948 Machine Data Sheet	7	Troubleshooting	39
SECTION 1: SAFETY	9	Calibrating Depth Stop.....	41
Safety Instructions for Machinery	9	Tensioning Spindle Return Spring.....	41
Additional Safety for Drill Presses	11	SECTION 8: WIRING	43
SECTION 2: POWER SUPPLY	12	Wiring Safety Instructions	43
Converting Voltage to 240V.....	14	Electrical Components.....	44
SECTION 3: SETUP	15	G7947/G7948 Wiring Diagram	45
Needed for Setup.....	15	SECTION 9: PARTS	46
Unpacking	15	G7947 Stand & Table Breakdown	46
Inventory	16	G7947 Headstock	47
Cleanup.....	17	G7948 Stand & Table Breakdown	50
Site Considerations.....	18	G7948 Headstock Breakdown	51
Anchoring to Floor	19	G7947/48 Labels & Cosmetics	54
Mounting to Mobile Base	19	WARRANTY AND RETURNS	57
Assembly	21		
Joining Drill Chuck & Arbor.....	25		
Test Run	26		
SECTION 4: OPERATIONS	27		
Operation Overview	27		
Calculating Spindle Speed for Drilling	28		
Changing Speeds	29		
Drilling	30		
Installing/Removing Drill Bits	31		
Setting Depth Stop.....	31		
Positioning Table	32		
Removing Arbor.....	33		

INTRODUCTION

Contact Info

We stand behind our machines! If you have questions or need help, contact us with the information below. Before contacting, make sure you get the **serial number** and **manufacture date** from the machine ID label. This will help us help you faster.

Grizzly Technical Support
1815 W. Battlefield
Springfield, MO 65807
Phone: (570) 546-9663
Email: techsupport@grizzly.com

We want your feedback on this manual. What did you like about it? Where could it be improved? Please take a few minutes to give us feedback.

Grizzly Documentation Manager
P.O. Box 2069
Bellingham, WA 98227-2069
Email: manuals@grizzly.com

Machine Description

The G7947 and G7948 function and operate the same but have the following differences:

G7947

- Table Size..... 13⁵/₈" x 13⁵/₈"
- Max. Movement of Work Table..... 21¹/₂"
- Number of T-Slots 2
- Swing..... 17"
- Floor-to-Table Height24" – 45¹/₂"
- Spindle Taper MT#3
- Base Size22¹/₂" x 14¹/₂"

G7948

- Table Size..... 18³/₄" x 16³/₄"
- Max. Movement of Work Table.....22"
- Number of T-Slots 3
- Swing.....20"
- Floor-to-Table Height25" – 47"
- Spindle Taper MT#4
- Base Size23" x 17¹/₂"

Manual Accuracy

We are proud to provide a high-quality owner's manual with your new machine!

We made every effort to be exact with the instructions, specifications, drawings, and photographs in this manual. Sometimes we make mistakes, but our policy of continuous improvement also means that **sometimes the machine you receive is slightly different than shown in the manual.**

If you find this to be the case, and the difference between the manual and machine leaves you confused or unsure about something, check our website for an updated version. We post current manuals and manual updates for free on our website at **www.grizzly.com**.

Alternatively, you can call our Technical Support for help. Before calling, make sure you write down the **Manufacture Date** and **Serial Number** from the machine ID label (see below). This information is required for us to provide proper tech support, and it helps us determine if updated documentation is available for your machine.

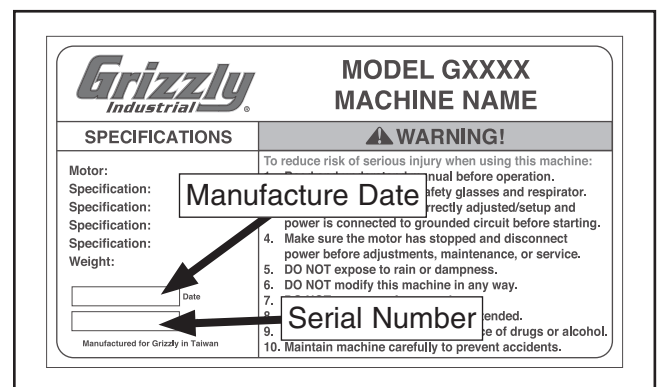

Identification

Become familiar with the names and locations of the controls and features shown below to better understand the instructions in this manual.

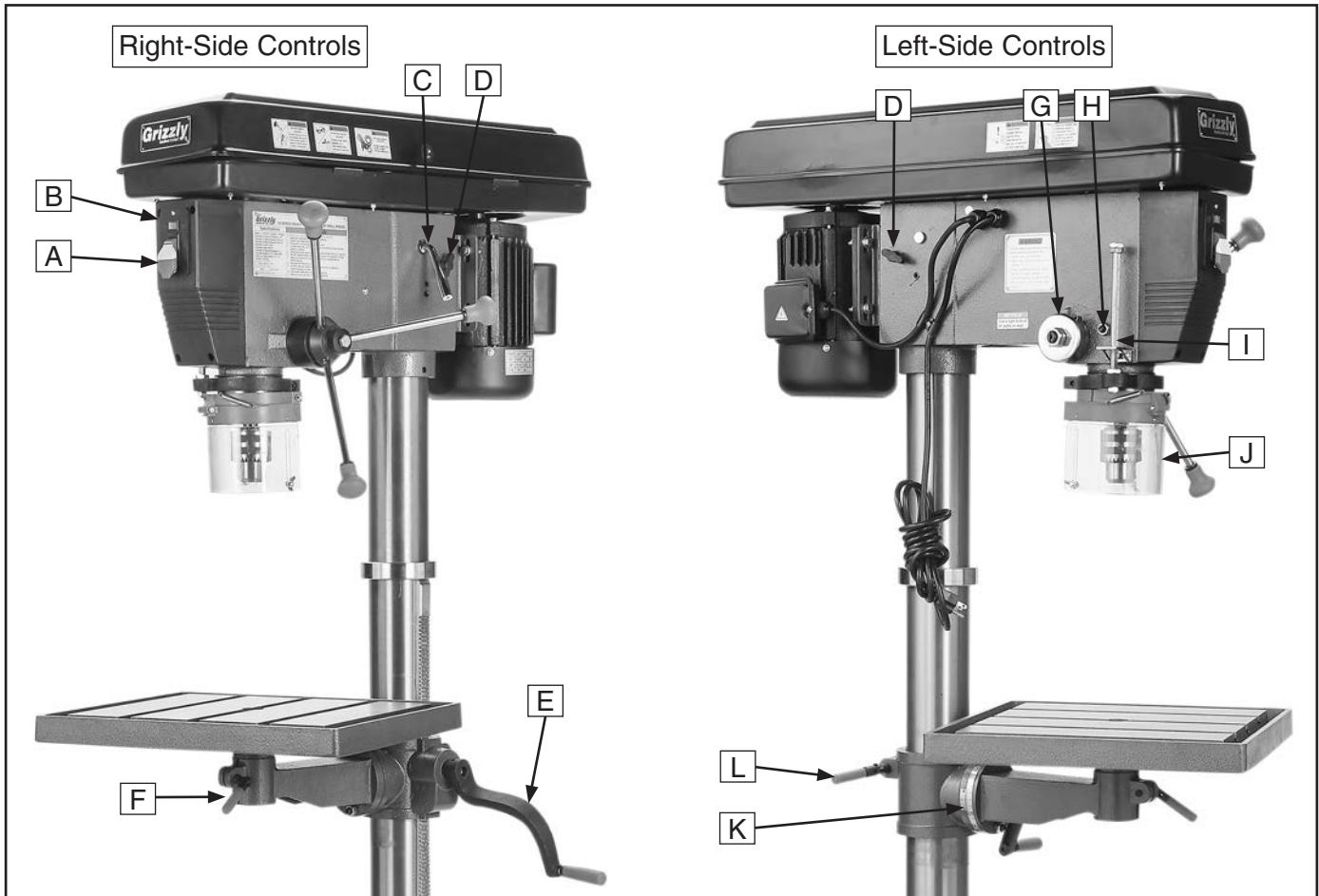

- A. Power Switch
- B. Light Switch
- C. Belt Tension Lever
- D. Belt Tension Lock
- E. Table Height Crank
- F. Table Lock Lever

- G. Spring
- H. Lash Screw
- I. Depth Stop
- J. Chuck Guard
- K. Scale
- L. Column Lock Lever

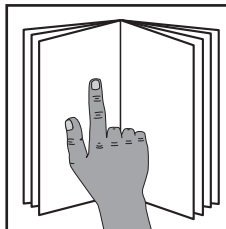

⚠️ WARNING

To reduce your risk of serious injury, read this entire manual **BEFORE** using machine.



Controls & Components



Refer to the following figures and descriptions to become familiar with the basic controls and components of this machine. Understanding these items and how they work will help you understand the rest of the manual and minimize your risk of injury when operating this machine.

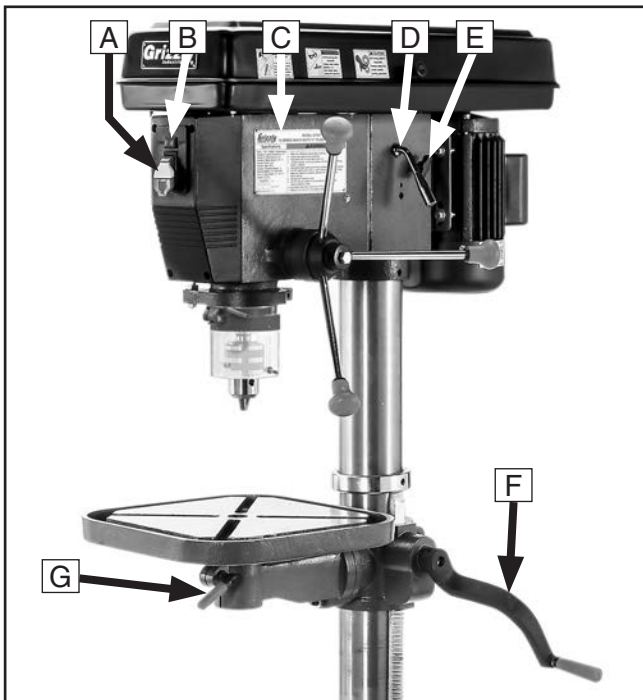

Figure 1. Headstock controls (right).

- A. **Power Switch:** Turns motor **ON/OFF**.
- B. **Light Switch:** Turns light **ON/OFF**.
- C. **Headstock:** The cast-iron upper portion of the drill press, which houses the quill and work light, and supports the motor and belt housing.
- D. **Belt Tension Lever:** Adjusts motor location to increase/decrease belt tension.

- E. **Belt Tension Locks:** Two knobs on each side of headstock lock motor in place.
- F. **Table Height Crank:** Raises/lowers table.
- G. **Table Lock Lever:** Locks table rotation.

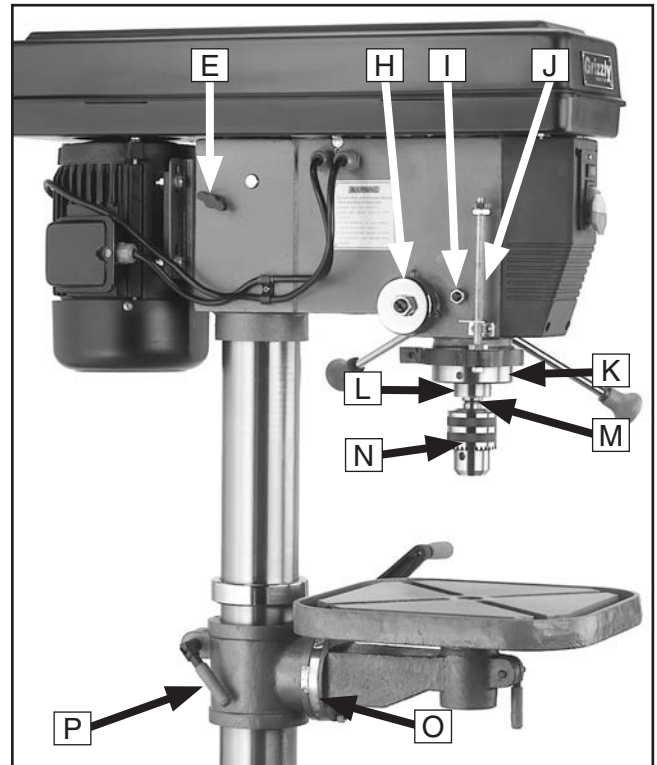

Figure 2. Headstock controls (left).

- H. **Spring:** Automatically returns quill into headstock.
- I. **Lash Screw:** Removes quill lash.
- J. **Depth Stop:** Limits quill travel to a pre-set drilling depth.
- K. **Quill:** Houses the spindle and bearings.
- L. **Spindle:** The hollow shaft that accepts the arbor.
- M. **Arbor:** A tapered shaft that connects the chuck to the spindle.
- N. **Chuck:** Accepts drill bits with shanks from $\frac{3}{64}$ " to $\frac{5}{8}$ " and uses a JT-3 key.
- O. **Scale:** Displays current table-tilt angle.
- P. **Column Lock Lever:** Locks table height.





MACHINE DATA SHEET

Customer Service #: (570) 546-9663 · To Order Call: (800) 523-4777 · Fax #: (800) 438-5901

MODEL G7947 17" FLOOR DRILL PRESS

Product Dimensions:

Weight..... 245 lbs.
Width (side-to-side) x Depth (front-to-back) x Height..... 21 x 30 x 70 in.
Footprint (Length x Width)..... 22-1/2 x 14-1/2 in.

Shipping Dimensions:

Type..... Cardboard Box
Content..... Machine
Weight..... 260 lbs.
Length x Width x Height..... 60 x 26 x 13 in.
Must Ship Upright..... Yes

Electrical:

Power Requirement..... 120V or 240V, Single-Phase, 60 Hz
Prewired Voltage..... 120V
Full-Load Current Rating..... 15.8A at 120V, 7.9A at 240V
Minimum Circuit Size..... 20A at 120V, 20A at 240V
Connection Type..... Cord & Plug
Power Cord Included..... Yes
Power Cord Length..... 6 ft.
Power Cord Gauge..... 14 AWG
Plug Included..... Yes
Included Plug Type..... 5-20 for 120V
Recommended Plug Type..... 6-15 for 240V
Switch Type..... Paddle Safety Switch w/Removable Key

Motors:

Main

Horsepower..... 1 1/2 HP
Phase..... Single-Phase
Amps..... 15.8A/7.9A
Speed..... 1725 RPM
Type..... TEFC Capacitor-Start Induction
Power Transfer V-Belt Drive
Bearings..... Shielded & Permanently Lubricated



Main Specifications:

Operation Information

Type.....	Floor
Swing.....	17 in.
Spindle Taper.....	MT#3
Spindle Travel.....	4-3/4 in.
Max. Distance From Spindle to Column.....	8-1/2 in.
Max. Distance From Spindle to Table.....	29 in.
Number of Spindle Speeds.....	12
Range of Spindle Speeds.....	180–3240 RPM
Max. Head Swivel.....	360 deg.
Drilling Capacity (Mild Steel).....	1 in. in Steel
Drill Chuck Type.....	JT3 Key Chuck
Drill Chuck Size.....	3/64 – 5/8 in.

Spindle Information

Distance From Spindle to Base.....	50-1/4 in.
Quill Diameter.....	2.85 in.

Table Information

Max. Table Tilt (Left/Right).....	90 deg.
Table Swing.....	360 deg.
Table Swivel Around Center.....	360 deg.
Table Swivel Around Column.....	360 deg.
Max. Movement of Work Table.....	21-1/2 in.
Table Length.....	13-5/8 in.
Table Width.....	13-5/8 in.
Table Thickness.....	1-1/2 in.
Vertical Table Travel.....	Crank Handle Operation
Number of T-Slots.....	2
T-Slot Size.....	5/8 in.
Floor-To-Table Height.....	24 – 45-1/2 in.

Construction

Table.....	Precision-Ground Cast Iron
Column.....	Steel
Spindle Housing.....	Cast Iron
Head.....	Cast Iron
Base.....	Cast Iron
Paint Type/Finish.....	Enamel

Other Related Information

Base Length.....	22-1/2 in.
Base Width.....	14-1/2 in.
Mobile Base.....	D2057A
Column Diameter.....	3.605 in.
Depth Stop Type.....	Threaded Rod with Positive Stop
Has Work Light.....	Yes
Light Socket Type.....	120V, Std Bulb
Maximum Bulb Wattage.....	60 W

Other Specifications:

Country of Origin	China
Warranty	1 Year
Approximate Assembly & Setup Time	45 Minutes
Serial Number Location	ID Label on Head
ISO 9001 Factory	Yes
Certified by a Nationally Recognized Testing Laboratory (NRTL)	Yes





MACHINE DATA SHEET

Customer Service #: (570) 546-9663 · To Order Call: (800) 523-4777 · Fax #: (800) 438-5901

MODEL G7948 20" FLOOR DRILL PRESS

Product Dimensions:

Weight..... 303 lbs.
 Width (side-to-side) x Depth (front-to-back) x Height..... 21 x 34-3/4 x 70-3/4 in.
 Footprint (Length x Width)..... 23 x 18 in.

Shipping Dimensions:

Type..... Cardboard Box
 Content..... Machine
 Weight..... 317 lbs.
 Length x Width x Height..... 61 x 26 x 13 in.
 Must Ship Upright..... Yes

Electrical:

Power Requirement..... 120V or 240V, Single-Phase, 60 Hz
 Prewired Voltage..... 120V
 Full-Load Current Rating..... 15.8A at 120V, 7.9A at 240V
 Minimum Circuit Size..... 20A at 120V, 15A at 240V
 Connection Type..... Cord & Plug
 Power Cord Included..... Yes
 Power Cord Length..... 6 ft.
 Power Cord Gauge..... 14 AWG
 Plug Included..... Yes
 Included Plug Type..... 5-20 for 120V
 Recommended Plug Type..... 6-15 for 240V
 Switch Type..... Paddle Safety Switch w/Removable Key

Motors:

Main

Horsepower..... 1.5 HP
 Phase..... Single-Phase
 Amps..... 15.8A/7.9A
 Speed..... 1725 RPM
 Type..... TEFC Capacitor-Start Induction
 Power Transfer V-Belt Drive
 Bearings..... Shielded & Permanently Lubricated



Main Specifications:

Operation Information

Type.....	Floor
Swing.....	20 in.
Spindle Taper.....	MT#4
Spindle Travel.....	4-3/4 in.
Max. Distance From Spindle to Column.....	10 in.
Max. Distance From Spindle to Table.....	28-1/2 in.
Number of Spindle Speeds.....	12
Range of Spindle Speeds.....	180-3240 RPM
Max. Head Swivel.....	360 deg.
Drilling Capacity (Mild Steel).....	1-1/4 in. in Steel
Drill Chuck Type.....	JT3 Key Chuck
Drill Chuck Size.....	3/64 – 5/8 in.

Spindle Information

Distance From Spindle to Base.....	50-1/4 in.
Quill Diameter.....	2.825 in.

Table Information

Max. Table Tilt (Left/Right).....	90 deg.
Table Swing.....	360 deg.
Table Swivel Around Center.....	78 deg.
Table Swivel Around Column.....	360 deg.
Max. Movement of Work Table.....	22 in.
Table Length.....	18-3/4 in.
Table Width.....	16-3/4 in.
Table Thickness.....	1-1/2 in.
Vertical Table Travel.....	Crank Handle Operation
Number of T-Slots.....	3
T-Slot Size.....	5/8 in.
T-Slot Centers.....	4-1/4 in.
Floor-To-Table Height.....	25 – 47 in.

Construction

Table.....	Precision-Ground Cast Iron
Column.....	Steel
Spindle Housing.....	Cast Iron
Head.....	Cast Iron
Base.....	Cast Iron
Paint Type/Finish.....	Enamel

Other Related Information

Base Length.....	23 in.
Base Width.....	17-1/2 in.
Mobile Base.....	D2057A
Column Diameter.....	3.642 in.
Depth Stop Type.....	Hub
Has Work Light.....	Yes
Light Socket Type.....	120V, Std Bulb



SECTION 1: SAFETY

For Your Own Safety, Read Instruction Manual Before Operating This Machine

The purpose of safety symbols is to attract your attention to possible hazardous conditions. This manual uses a series of symbols and signal words intended to convey the level of importance of the safety messages. The progression of symbols is described below. Remember that safety messages by themselves do not eliminate danger and are not a substitute for proper accident prevention measures. Always use common sense and good judgment.



Indicates an imminently hazardous situation which, if not avoided, **WILL** result in death or serious injury.



Indicates a potentially hazardous situation which, if not avoided, **COULD** result in death or serious injury.



Indicates a potentially hazardous situation which, if not avoided, **MAY** result in minor or moderate injury. It may also be used to alert against unsafe practices.

NOTICE

Alerts the user to useful information about proper operation of the machine to avoid machine damage.

Safety Instructions for Machinery

WARNING

OWNER'S MANUAL. Read and understand this owner's manual **BEFORE** using machine.

TRAINED OPERATORS ONLY. Untrained operators have a higher risk of being hurt or killed. Only allow trained/supervised people to use this machine. When machine is not being used, disconnect power, remove switch keys, or lock-out machine to prevent unauthorized use—especially around children. Make your workshop kid proof!

DANGEROUS ENVIRONMENTS. Do not use machinery in areas that are wet, cluttered, or have poor lighting. Operating machinery in these areas greatly increases the risk of accidents and injury.

MENTAL ALERTNESS REQUIRED. Full mental alertness is required for safe operation of machinery. Never operate under the influence of drugs or alcohol, when tired, or when distracted.

ELECTRICAL EQUIPMENT INJURY RISKS. You can be shocked, burned, or killed by touching live electrical components or improperly grounded machinery. To reduce this risk, only allow qualified service personnel to do electrical installation or repair work, and always disconnect power before accessing or exposing electrical equipment.

DISCONNECT POWER FIRST. Always disconnect machine from power supply **BEFORE** making adjustments, changing tooling, or servicing machine. This prevents an injury risk from unintended startup or contact with live electrical components.

EYE PROTECTION. Always wear ANSI-approved safety glasses or a face shield when operating or observing machinery to reduce the risk of eye injury or blindness from flying particles. Everyday eyeglasses are **NOT** approved safety glasses.



WARNING

WEARING PROPER APPAREL. Do not wear clothing, apparel or jewelry that can become entangled in moving parts. Always tie back or cover long hair. Wear non-slip footwear to reduce risk of slipping and losing control or accidentally contacting cutting tool or moving parts.

HAZARDOUS DUST. Dust created by machinery operations may cause cancer, birth defects, or long-term respiratory damage. Be aware of dust hazards associated with each workpiece material. Always wear a NIOSH-approved respirator to reduce your risk.

HEARING PROTECTION. Always wear hearing protection when operating or observing loud machinery. Extended exposure to this noise without hearing protection can cause permanent hearing loss.

REMOVE ADJUSTING TOOLS. Tools left on machinery can become dangerous projectiles upon startup. Never leave chuck keys, wrenches, or any other tools on machine. Always verify removal before starting!

USE CORRECT TOOL FOR THE JOB. Only use this tool for its intended purpose—do not force it or an attachment to do a job for which it was not designed. Never make unapproved modifications—modifying tool or using it differently than intended may result in malfunction or mechanical failure that can lead to personal injury or death!

AWKWARD POSITIONS. Keep proper footing and balance at all times when operating machine. Do not overreach! Avoid awkward hand positions that make workpiece control difficult or increase the risk of accidental injury.

CHILDREN & BYSTANDERS. Keep children and bystanders at a safe distance from the work area. Stop using machine if they become a distraction.

GUARDS & COVERS. Guards and covers reduce accidental contact with moving parts or flying debris. Make sure they are properly installed, undamaged, and working correctly BEFORE operating machine.

FORCING MACHINERY. Do not force machine. It will do the job safer and better at the rate for which it was designed.

NEVER STAND ON MACHINE. Serious injury may occur if machine is tipped or if the cutting tool is unintentionally contacted.

STABLE MACHINE. Unexpected movement during operation greatly increases risk of injury or loss of control. Before starting, verify machine is stable and mobile base (if used) is locked.

USE RECOMMENDED ACCESSORIES. Consult this owner's manual or the manufacturer for recommended accessories. Using improper accessories will increase the risk of serious injury.

UNATTENDED OPERATION. To reduce the risk of accidental injury, turn machine **OFF** and ensure all moving parts completely stop before walking away. Never leave machine running while unattended.

MAINTAIN WITH CARE. Follow all maintenance instructions and lubrication schedules to keep machine in good working condition. A machine that is improperly maintained could malfunction, leading to serious personal injury or death.

DAMAGED PARTS. Regularly inspect machine for damaged, loose, or mis-adjusted parts—or any condition that could affect safe operation. Immediately repair/replace BEFORE operating machine. For your own safety, DO NOT operate machine with damaged parts!

MAINTAIN POWER CORDS. When disconnecting cord-connected machines from power, grab and pull the plug—NOT the cord. Pulling the cord may damage the wires inside. Do not handle cord/plug with wet hands. Avoid cord damage by keeping it away from heated surfaces, high traffic areas, harsh chemicals, and wet/damp locations.

EXPERIENCING DIFFICULTIES. If at any time you experience difficulties performing the intended operation, stop using the machine! Contact our Technical Support at (570) 546-9663.



Additional Safety for Drill Presses

WARNING

Serious injury or death can occur from getting clothing, jewelry, or long hair entangled in rotating spindle or bit/cutting tool. Contact with rotating bit/cutting tool can result in severe cuts or amputation of fingers. Flying metal chips can cause blindness or eye injuries. Broken bits/cutting tools, unsecured workpieces, chuck keys, or other adjustment tools thrown from rotating spindle can strike nearby operator or bystanders with deadly force. To reduce the risk of these hazards, operator and bystanders **MUST** completely heed hazards and warnings below.

EYE/FACE/HAND PROTECTION. Flying chips created by drilling can cause eye injuries or blindness. Always wear a face shield in addition to safety glasses. Always keep hands and fingers away from drill bit/cutting tool. Avoid awkward hand positions, where a sudden slip could cause hand to move into bit/cutting tool.

AVOIDING ENTANGLEMENT. DO NOT wear loose clothing, gloves, or jewelry. Tie back long hair. Keep all guards in place and secure. Always allow spindle to stop on its own. DO NOT stop spindle using your hand or any other object.

REMOVING ADJUSTMENT TOOLS. Chuck key, wrenches, and other tools left on machine can become deadly projectiles when spindle is started. Remove all loose items or tools used on spindle immediately after use.

CORRECT SPINDLE SPEED. Using wrong spindle speed can cause bits/cutting tools to break and strike operator or bystanders. Follow recommended speeds and feeds for each size/type of bit/cutting tool and workpiece material.

SECURING BIT/CUTTING TOOL. Firmly secure bit/cutting tool in chuck so it cannot fly out of spindle during operation or startup.

DRILLING PREPARATION. To avoid loss of drilling control or bit breakage, only drill into a flat surface that is approximately perpendicular to bit. Clear table of all objects before starting spindle. Never start spindle with bit pressed against workpiece.

SECURING TABLE AND HEADSTOCK. To avoid loss of control leading to accidental contact with tool/bit, tighten all table and headstock locks before operating drill press.

WORKPIECE CONTROL. An unsecured workpiece may unexpectedly shift, spin out of control, or be thrown if bit/cutting tool “grabs” during operation. Clamp workpiece to table or in table-mounted vise, or brace against column to prevent rotation. NEVER hold workpiece by hand during operation. NEVER start machine with bit/cutting tool touching workpiece; allow spindle to gain full speed before drilling.

INSPECTING BIT/CUTTING TOOL. Damaged bits/cutting tools may break apart during operation and hit operator or bystanders. Dull bits/cutting tools increase cutting resistance and are more likely to grab and spin/throw workpiece. Always inspect bits/cutting tools for sharpness, chips, or cracks before each use. Replace dull, chipped, or cracked bits/cutting tools immediately.

WARNING

Like all machinery there is potential danger when operating this machine. Accidents are frequently caused by lack of familiarity or failure to pay attention. Use this machine with respect and caution to decrease the risk of operator injury. If normal safety precautions are overlooked or ignored, serious personal injury may occur.

CAUTION

No list of safety guidelines can be complete. Every shop environment is different. Always consider safety first, as it applies to your individual working conditions. Use this and other machinery with caution and respect. Failure to do so could result in serious personal injury, damage to equipment, or poor work results.



SECTION 2: POWER SUPPLY

Availability

Before installing the machine, consider the availability and proximity of the required power supply circuit. If an existing circuit does not meet the requirements for this machine, a new circuit must be installed. To minimize the risk of electrocution, fire, or equipment damage, installation work and electrical wiring must be done by an electrician or qualified service personnel in accordance with all applicable codes and standards.

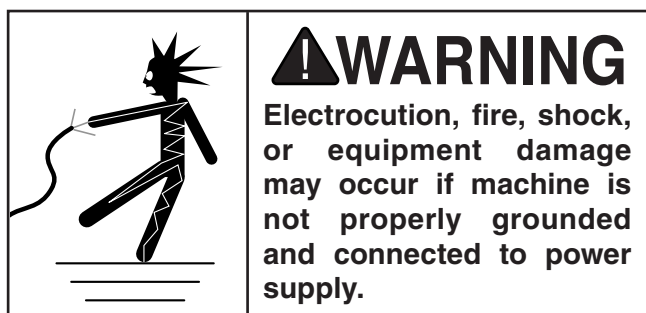

Full-Load Current Rating

The full-load current rating is the amperage a machine draws at 100% of the rated output power. On machines with multiple motors, this is the amperage drawn by the largest motor or sum of all motors and electrical devices that might operate at one time during normal operations.

Full-Load Current Rating at 120V .. 15.8 Amps

Full-Load Current Rating at 240V 7.9 Amps

The full-load current is not the maximum amount of amps that the machine will draw. If the machine is overloaded, it will draw additional amps beyond the full-load rating.

If the machine is overloaded for a sufficient length of time, damage, overheating, or fire may result—especially if connected to an undersized circuit. To reduce the risk of these hazards, avoid overloading the machine during operation and make sure it is connected to a power supply circuit that meets the specified circuit requirements.

Circuit Information

A power supply circuit includes all electrical equipment between the breaker box or fuse panel in the building and the machine. The power supply circuit used for this machine must be sized to safely handle the full-load current drawn from the machine for an extended period of time. (If this machine is connected to a circuit protected by fuses, use a time delay fuse marked D.)

! CAUTION
For your own safety and protection of property, consult an electrician if you are unsure about wiring practices or electrical codes in your area.

Note: *Circuit requirements in this manual apply to a dedicated circuit—where only one machine will be running on the circuit at a time. If machine will be connected to a shared circuit where multiple machines may be running at the same time, consult an electrician or qualified service personnel to ensure circuit is properly sized for safe operation.*

Circuit Requirements for 120V

This machine is prewired to operate on a power supply circuit that has a verified ground and meets the following requirements:

Nominal Voltage 120V
Cycle 60 Hz
Phase Single-Phase
Power Supply Circuit 20 Amps
Plug/Receptacle NEMA 5-20

Circuit Requirements for 240V

This machine can be converted to operate on a power supply circuit that has a verified ground and meets the requirements listed below. (Refer to **Voltage Conversion** instructions for details.)

Nominal Voltage 240V
Cycle 60 Hz
Phase Single-Phase
Power Supply Circuit 15 Amps
Plug/Receptacle NEMA 6-15



Grounding Requirements

This machine **MUST** be grounded. In the event of certain malfunctions or breakdowns, grounding reduces the risk of electric shock by providing a path of least resistance for electric current.

For 120V operation: This machine is equipped with a power cord that has an equipment-grounding wire and a grounding plug (see following figure). The plug must only be inserted into a matching receptacle (outlet) that is properly installed and grounded in accordance with all local codes and ordinances.

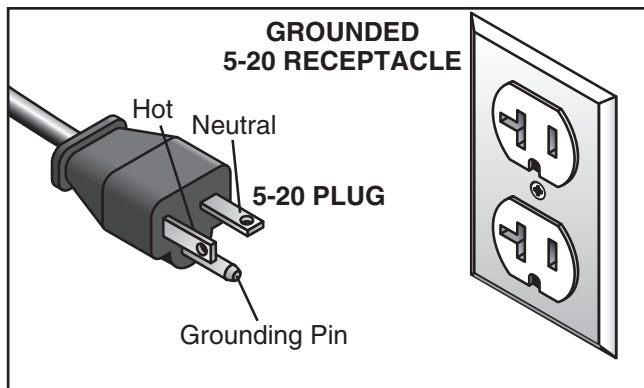

Figure 3. Typical 5-20 plug and receptacle.

⚠ CAUTION

SHOCK HAZARD!
Two-prong outlets do not meet the grounding requirements for this machine. Do not modify or use an adapter on the plug provided—if it will not fit the outlet, have a qualified electrician install the proper outlet with a verified ground.

For 240V operation: The plug specified under “Circuit Requirements for 240V” on the previous page has a grounding prong that must be attached to the equipment-grounding wire on the included power cord. The plug must only be inserted into a matching receptacle (see following figure) that is properly installed and grounded in accordance with all local codes and ordinances.

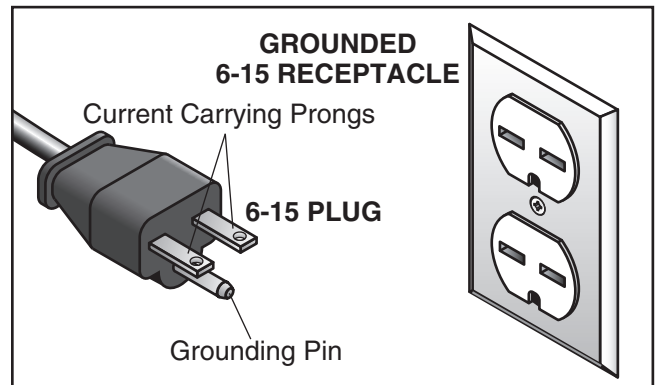

Figure 4. Typical 6-15 plug and receptacle.

Improper connection of the equipment-grounding wire can result in a risk of electric shock. The wire with green insulation (with or without yellow stripes) is the equipment-grounding wire. If repair or replacement of the power cord or plug is necessary, do not connect the equipment-grounding wire to a live (current carrying) terminal.

Check with a qualified electrician or service personnel if you do not understand these grounding requirements, or if you are in doubt about whether the tool is properly grounded. If you ever notice that a cord or plug is damaged or worn, disconnect it from power, and immediately replace it with a new one.

Extension Cords

We do not recommend using an extension cord with this machine. If you must use an extension cord, only use it if absolutely necessary and only on a temporary basis.

Extension cords cause voltage drop, which can damage electrical components and shorten motor life. Voltage drop increases as the extension cord size gets longer and the gauge size gets smaller (higher gauge numbers indicate smaller sizes).

Any extension cord used with this machine must be in good condition and contain a ground wire and matching plug/receptacle. Additionally, it must meet the following size requirements:

Minimum Gauge Size 12 AWG
Maximum Length (Shorter is Better).....50 ft.



Converting Voltage to 240V

The voltage conversion MUST be performed by an electrician or qualified service personnel.

The voltage conversion procedure consists of rewiring the motor and installing the correct plug. A wiring diagram is provided on **Page 46** for your reference.

IMPORTANT: If the diagram included on the motor conflicts with the one on **Page 46**, the motor may have changed since the manual was printed. Use the diagram included on the motor instead.

Items Needed	Qty
Phillips Head Screwdriver #2	1
Electrical Tape	As Needed
Wire Nut 14 AWG	1
NEMA 6-15 Plug	1
Wire Cutters/Strippers	1



NOTICE
DO NOT USE light bulb after machine is converted to 240V operation to avoid bulb explosion.

To convert machine to 240V:

1. DISCONNECT MACHINE FROM POWER!
2. Cut off existing 5-20 plug from cord.
3. Disconnect wires 2 and 3 from terminal block (see **Figure 5**), then re-tighten screws.

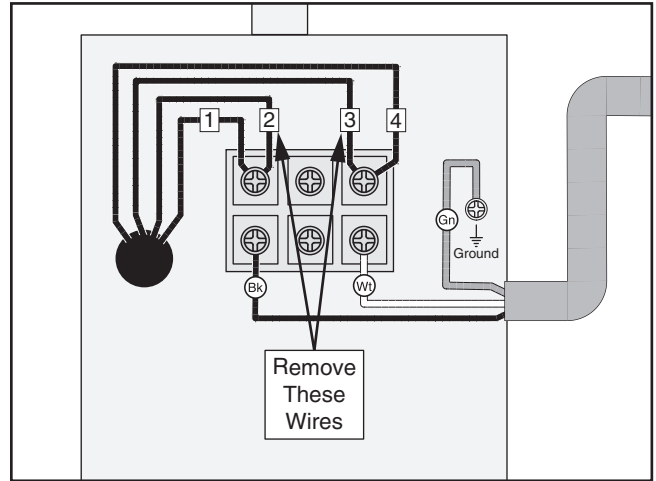

Figure 5. Motor prewired for 120V.

4. Rewire motor, as shown in **Figure 6**.

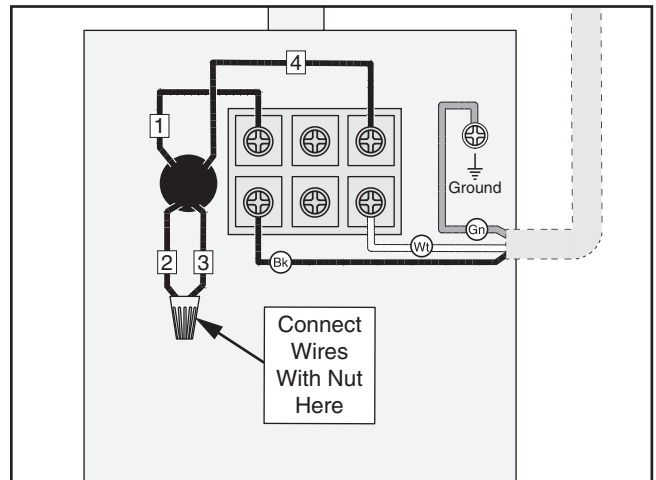

Figure 6. Motor rewired for 240V.

5. Tighten wire nut and wrap it with electrical tape so it cannot vibrate loose during motor operation.
6. Install 6-15 plug on the power cord per plug manufacturer's instructions.

Note: If plug manufacturer's instructions are not available, NEMA standard 6-15 plug wiring is provided on **Page 46**.



SECTION 3: SETUP

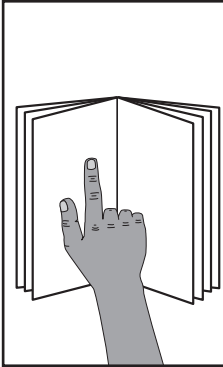

!WARNING

This machine presents serious injury hazards to untrained users. Read through this entire manual to become familiar with the controls and operations before starting the machine!

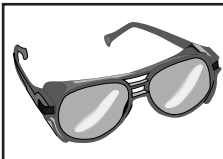

!WARNING

Wear safety glasses during the entire setup process!

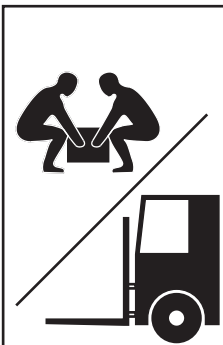

!WARNING

HEAVY LIFT!

Straining or crushing injury may occur from improperly lifting machine or some of its parts. To reduce this risk, get help from other people and use a forklift (or other lifting equipment) rated for weight of this machine.

Needed for Setup

The following items are needed, but not included, for the setup/assembly of this machine.

Items Needed	Qty
Safety Glasses (Per Person)	1
Open-End Wrench 18mm	1
Plumb Bob	1
Additional People	2
Rubber Mallet	1
60W Light Bulb (120V operation only)	1
Permanent Marker	1
Cleaner/Degreaser (Page 17)	As Needed

Unpacking

This machine was carefully packaged for safe transport. When unpacking, separate all enclosed items from packaging materials and inspect them for shipping damage. ***If items are damaged, please call us immediately at (570) 546-9663.***

IMPORTANT: Save all packaging materials until you are completely satisfied with the machine and have resolved any issues between Grizzly or the shipping agent. ***You MUST have the original packaging to file a freight claim. It is also extremely helpful if you need to return your machine later.***



Inventory

The following is a list of items shipped with your machine. Before beginning setup, lay these items out and inventory them.

If any non-proprietary parts are missing (e.g. a nut or a washer), we will gladly replace them; or for the sake of expediency, replacements can be obtained at your local hardware store.

NOTICE

If you cannot find an item on this list, carefully check around/inside the machine and packaging materials. Often, these items get lost in packaging materials while unpacking or they are pre-installed at the factory.

Description	Qty
A. Base	1
B. Hardware Bag	1
—Belt Cover Knob	1
—Hex Wrench 3mm	1
—Hex Wrench 4mm	1
—Hex Wrench 5mm	1
—Hex Bolts M12-1.75 x 45mm	4
C. Drift Key	1
D. Arbor	1
E. Chuck Key	1
F. Chuck	1

Description	Qty
G. Lock Wrench	1
H. Downfeed Handles	3
I. Small Lock Lever	1
J. Large Lock Lever	1
K. Table Support Assembly	1
L. Pinion	1
M. Headstock Assembly	1
N. Crank Lever	1
O. Handle	1
P. Table	1
Q. Column	1

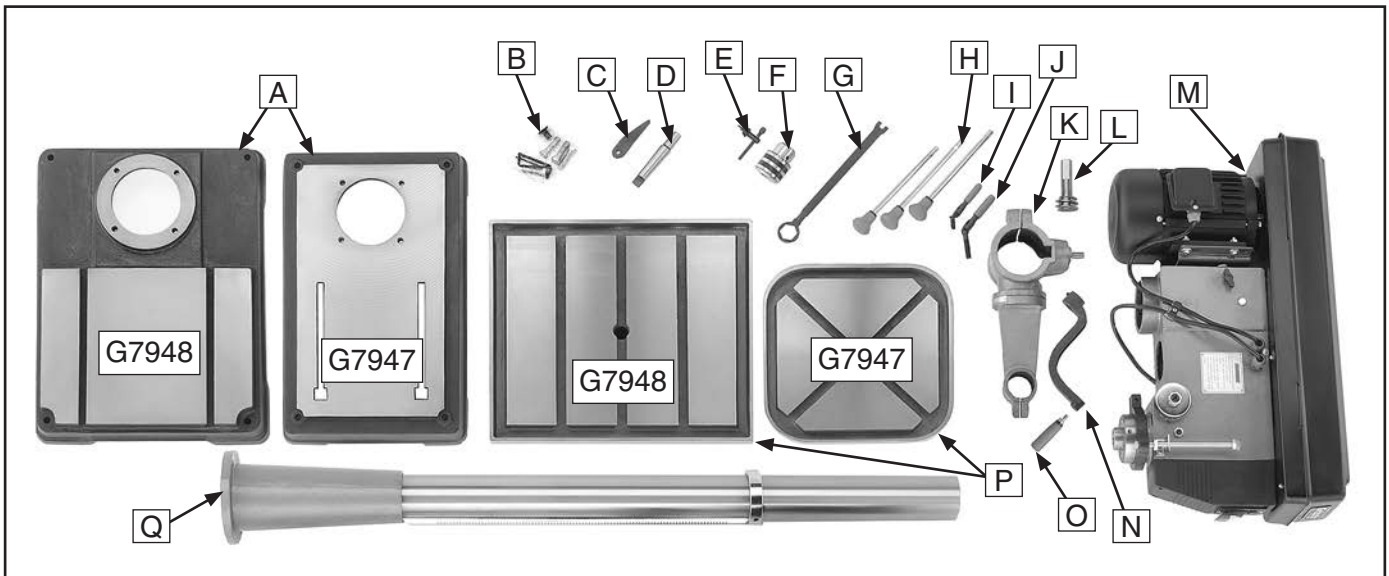

Figure 7. G7947/G7948 box inventory.



Cleanup

The unpainted surfaces of your machine are coated with a heavy-duty rust preventative that prevents corrosion during shipment and storage. This rust preventative works extremely well, but it will take a little time to clean.

Be patient and do a thorough job cleaning your machine. The time you spend doing this now will give you a better appreciation for the proper care of your machine's unpainted surfaces.

There are many ways to remove this rust preventative, but the following steps work well in a wide variety of situations. Always follow the manufacturer's instructions with any cleaning product you use and make sure you work in a well-ventilated area to minimize exposure to toxic fumes.

Before cleaning, gather the following:

- Disposable rags
- Cleaner/degreaser (WD•40 works well)
- Safety glasses & disposable gloves
- Plastic paint scraper (optional)

Basic steps for removing rust preventative:

1. Put on safety glasses.
2. Coat the rust preventative with a liberal amount of cleaner/degreaser, then let it soak for 5–10 minutes.
3. Wipe off the surfaces. If your cleaner/degreaser is effective, the rust preventative will wipe off easily. If you have a plastic paint scraper, scrape off as much as you can first, then wipe off the rest with the rag.
4. Repeat **Steps 2–3** as necessary until clean, then coat all unpainted surfaces with a quality metal protectant to prevent rust.

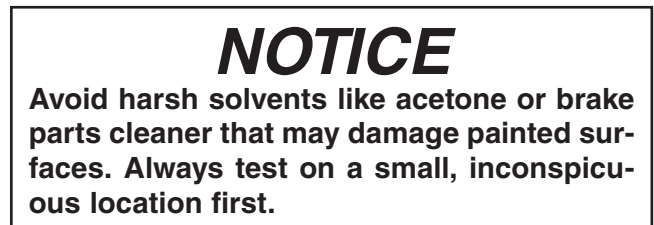
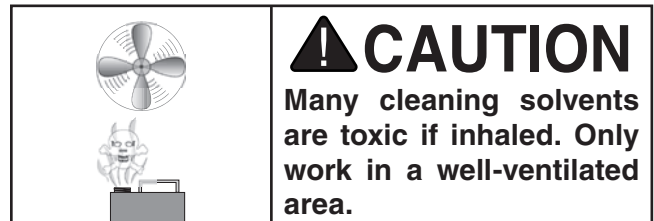
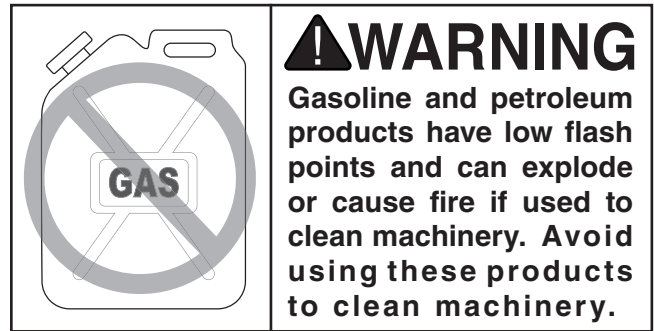

T23692—Orange Power Degreaser

A great product for removing the waxy shipping grease from the **non-painted** parts of the machine during clean up.



Figure 8. T23692 Orange Power Degreaser.



Site Considerations

Weight Load

Refer to the **Machine Data Sheet** for the weight of your machine. Make sure that the surface upon which the machine is placed will bear the weight of the machine, additional equipment that may be installed on the machine, and the heaviest workpiece that will be used. Additionally, consider the weight of the operator and any dynamic loading that may occur when operating the machine.

Space Allocation

Consider the largest size of workpiece that will be processed through this machine and provide enough space around the machine for adequate operator material handling or the installation of auxiliary equipment. With permanent installations, leave enough space around the machine to open or remove doors/covers as required by the maintenance and service described in this manual. **See below for required space allocation.**

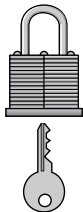
	<p>CAUTION</p> <p>Children or untrained people may be seriously injured by this machine. Only install in an access restricted location.</p>
---	--

Physical Environment

The physical environment where the machine is operated is important for safe operation and longevity of machine components. For best results, operate this machine in a dry environment that is free from excessive moisture, hazardous chemicals, airborne abrasives, or extreme conditions. Extreme conditions for this type of machinery are generally those where the ambient temperature range exceeds 41°–104°F; the relative humidity range exceeds 20%–95% (non-condensing); or the environment is subject to vibration, shocks, or bumps.

Electrical Installation

Place this machine near an existing power source. Make sure all power cords are protected from traffic, material handling, moisture, chemicals, or other hazards. Make sure to leave enough space around machine to disconnect power supply or apply a lockout/tagout device, if required.

Lighting

Lighting around the machine must be adequate enough that operations can be performed safely. Shadows, glare, or strobe effects that may distract or impede the operator must be eliminated.

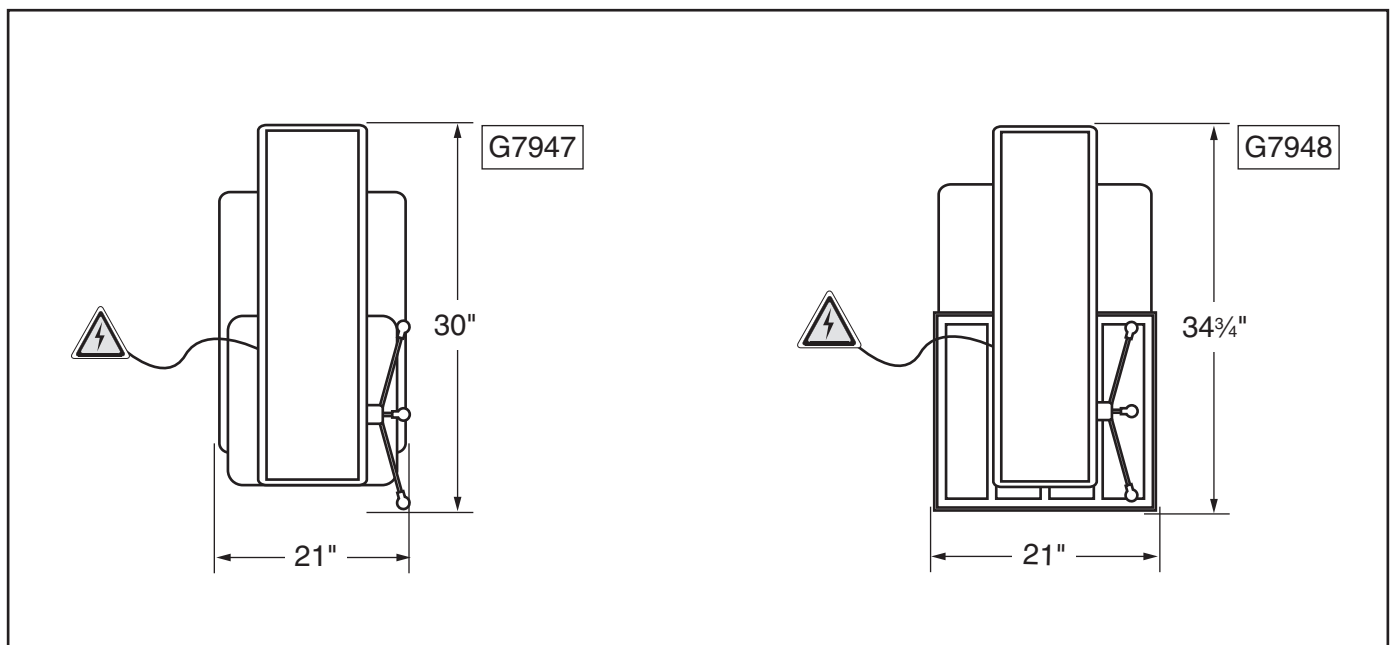

Figure 9. Working clearances.



Anchoring to Floor

Number of Mounting Holes 4
Diameter of Mounting Hardware..... 1/2"

Anchoring machinery to the floor prevents tipping or shifting and reduces vibration that may occur during operation, resulting in a machine that runs slightly quieter and feels more solid.

If the machine will be installed in a commercial or workplace setting, or if it is permanently connected (hardwired) to the power supply, local codes may require that it be anchored to the floor.

If not required by any local codes, fastening the machine to the floor is an optional step. If you choose not to do this with your machine, we recommend placing it on machine mounts, as these provide an easy method for leveling and they have vibration-absorbing pads.

Anchoring to Concrete Floors

Lag shield anchors with lag screws (see below) are a popular way to anchor machinery to a concrete floor, because the anchors sit flush with the floor surface, making it easy to unbolt and move the machine later, if needed. However, anytime local codes apply, you **MUST** follow the anchoring methodology specified by the code.

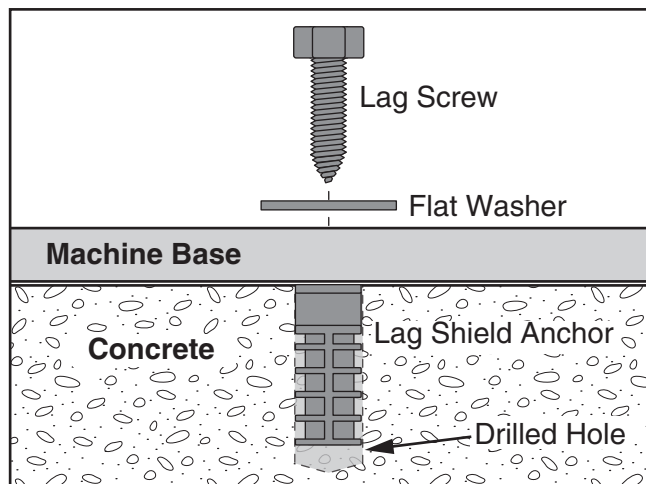

Figure 10. Popular method for anchoring machinery to a concrete floor.

Mounting to Mobile Base

Because the drill press is top-heavy by nature, we recommend mounting it to the floor, rather than a mobile base.

If you must use a mobile base, **ALWAYS** mount your drill press to a base plate inside of the mobile base, as shown in **Figure 11**.

A good quality base plate increases the standard footprint of the drill press to make it much more stable. The base plate must be at least 1 1/2" thick and made of plywood (do not use OSB, MDF, or particle board) to hold the weight of the drill press. A common way for making the baseplate is described in this sub-section.

Always use extreme care when moving the drill press around with the mobile base!

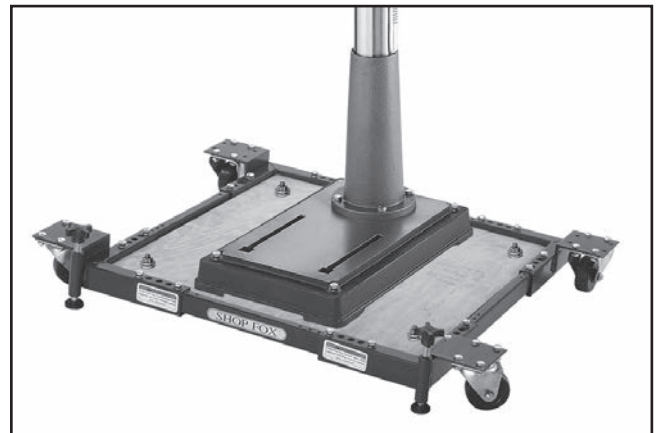

Figure 11. Drill press mounted on mobile base, using a base plate for support.

CAUTION

Drill presses are top-heavy and must be securely attached to a large-footprint base plate when used with a mobile base. Failure to use a base plate greatly increases possibility of tipping and personal injury.



Items Needed	Qty
Plywood $\frac{3}{4}$ " x $23\frac{3}{4}$ " x $23\frac{3}{4}$ "	2
Wood Glue.....	As Needed
Wood Screws #6 x $\frac{1}{4}$ "	24
Hex Bolts ($2\frac{1}{4}$ " Long, Sized for Base Plate)	4
Hex Nuts (Sized for Hex Bolts).....	4
Lock Washers (Sized for Hex Bolts).....	4
Flat Washers (Sized for Hex Bolts)	8
Assistant to Lift Drill Press	1

To make and use the base plate:

1. Glue the two pieces of plywood together, aligning edges and corners to make one thick piece.
2. Use wood screws to secure boards together from both sides.
3. Allow 24 hours for glue to dry before mounting drill press.
4. Place plywood base plate on mobile base.
5. Drill holes through base plate and metal plates at mobile base corners.
6. Secure base plate to mobile base with hex bolts, hex nuts, flat washers and lock washers, as shown in **Figure 12**.

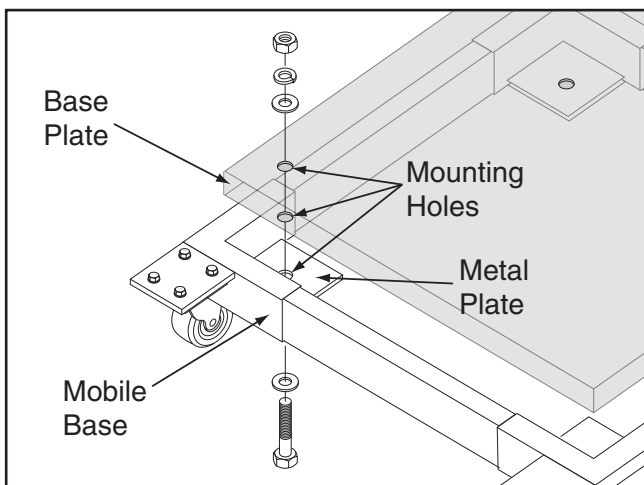

Figure 12. Mounting base plate to mobile base.

7. With help of an assistant, place drill press on base plate.
8. Position drill press close to front of mobile base, so mobile base will not become a tripping hazard.
9. Mount drill press to base plate with lag bolts and flat washers, as shown in **Figure 13**, or with through bolts, flat washers, and hex nuts.

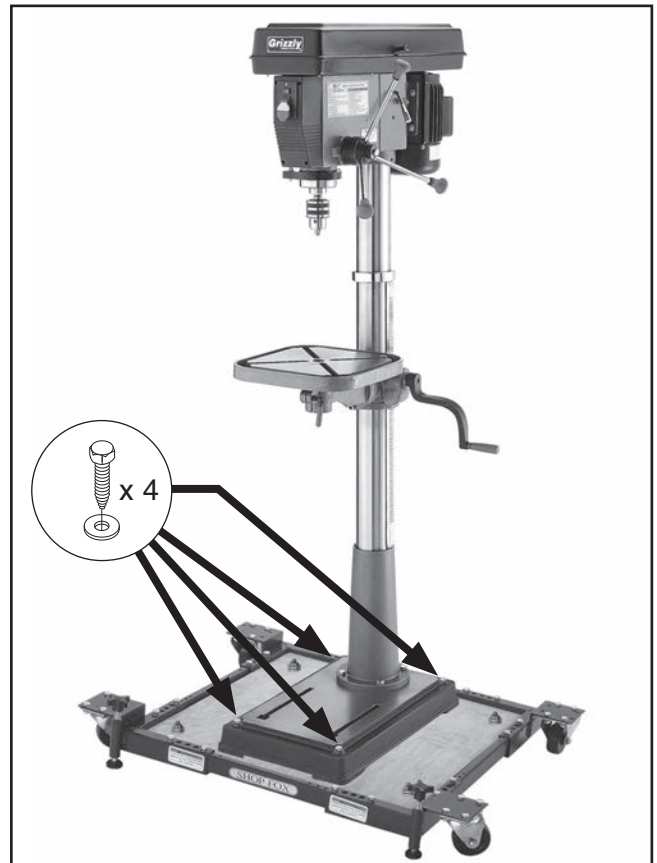

Figure 13. Drill press bolted to mobile base, using lag bolts and flat washers.



Assembly

The machine must be fully assembled before it can be operated. Before beginning the assembly process, refer to **Needed for Setup** and gather all listed items. To ensure the assembly process goes smoothly, first clean any parts that are covered or coated in heavy-duty rust preventative (if applicable).

The column must be secured on the base to properly assemble your drill press.

To assemble the machine:

1. Place column on base and align mounting holes.
2. Secure column to base with (4) hex bolts, as shown in **Figure 14**.

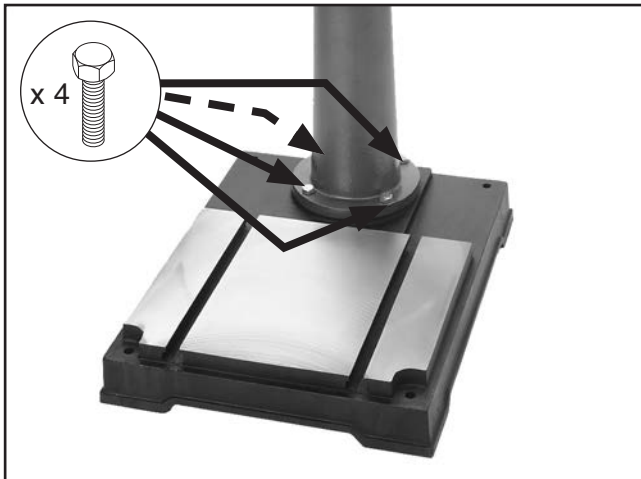

Figure 14. Column secured to base.

3. Place pinion in table support, as shown in **Figure 15**, so pinion and gear teeth mesh together.

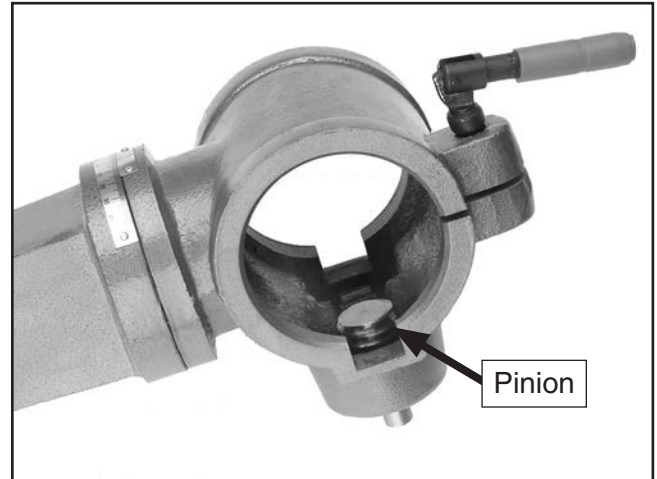

Figure 15. Pinion correctly installed in table support.

4. Mark top of rack, as shown in **Figure 16**, to keep track of which end is up.

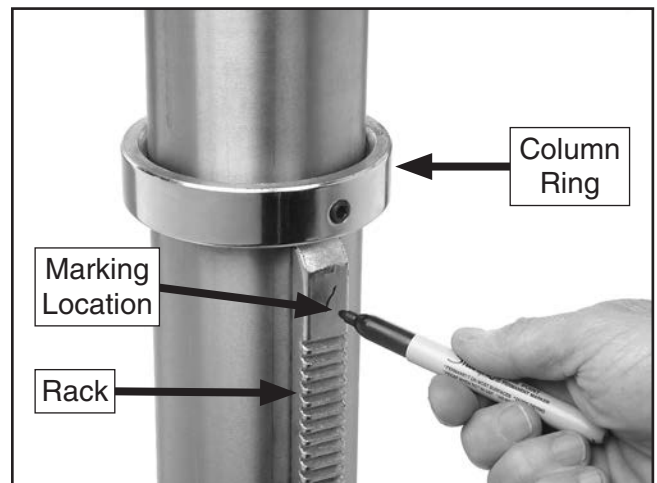

Figure 16. Marking top of rack to show which end is up.

5. Remove column ring by loosening set screw, and remove rack.



- Place rack inside of table support assembly, mesh it with pinion, and slide table support/rack assembly over column, as shown in **Figure 17**.



Figure 17. Sliding table support and rack over the column.

- Slide column ring over column with beveled edge facing down, as shown in **Figure 18**, then fit beveled edge of column ring over rack and tighten set screw.

Note: Do not overtighten the set screw or you may split the column ring. Also make sure the rack is seated firmly in the lower ring.



Figure 18. Correct column ring orientation.

- Install crank lever over pinion shaft, and tighten set screw in crank handle against flat part of pinion shaft.
- Thread handle into crank lever.

- Thread large lock lever into back of table support assembly approximately three turns, for now.
- Thread small lock lever into front part of table support assembly approximately three turns, for now. The assembly should match what is shown in **Figure 19**.

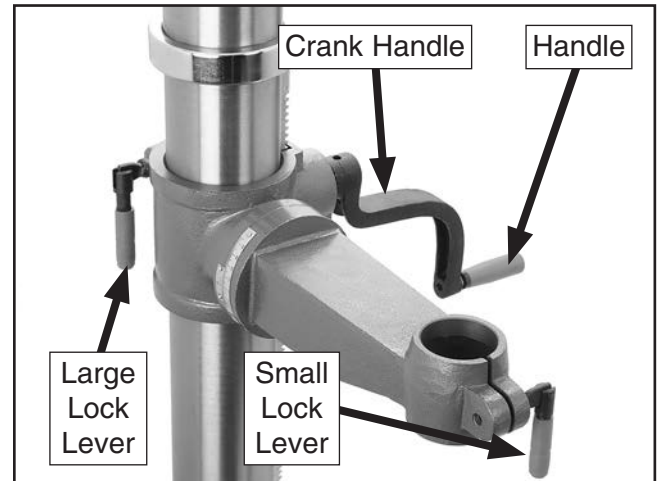

Figure 19. Handles and lock levers installed.

	<p>! WARNING</p> <p>The headstock is very heavy. You MUST have assistance when moving, lifting or mounting the headstock on the column and base assembly.</p>
--	---

- Set top piece of headstock Styrofoam packing approximately 6 feet away from column/base assembly.
- Remove headstock from box and place it on Styrofoam packing you laid out in **Step 1**.

Note: To avoid damaging the machine, be careful not to hold the headstock by the switch or the top part of the belt cover when lifting.

- Carefully lay column/base on its side.
- Slide column all the way into bottom of headstock (approximately 4"-6").



16. Tilt entire assembly up (see **Figure 20**) and carefully position drill press on its base in the fully upright position.

⚠ CAUTION

If the base starts to slide when tilting, you **MUST** have a third person hold the base from sliding to avoid personal injury or machine damage.



Figure 20. Tilting drill press upright.

17. Suspend a plumb bob from center of headstock spindle so it is over tape/ruler as shown in **Figure 21**.

18. Center headstock directly over base as indicated by plumb bob and ruler (see **Figure 21**).

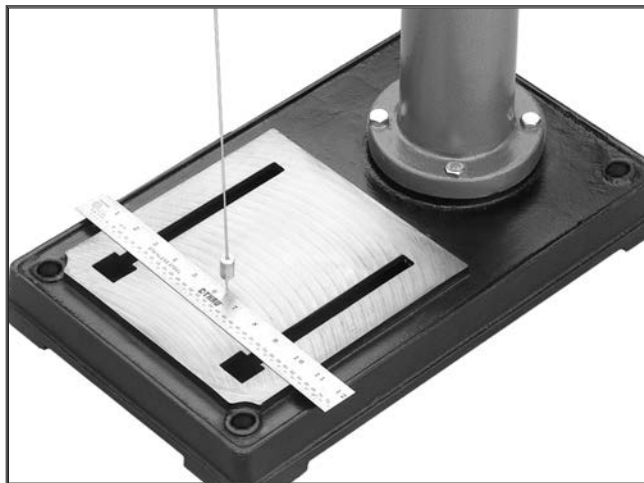

Figure 21. Aligning headstock with base.

19. Tighten (2) headstock set screws to column, as shown in **Figure 22**.



Figure 22. Securing headstock to column.



- To install chuck guard, place chuck guard over flange of depth gauge mount, as shown in **Figure 23**, then tighten Phillips head screw and hex nut to secure it.

Note: To prevent the guard from slipping off, move the table up to support it. Or, have an assistant hold the guard in place while you secure it.

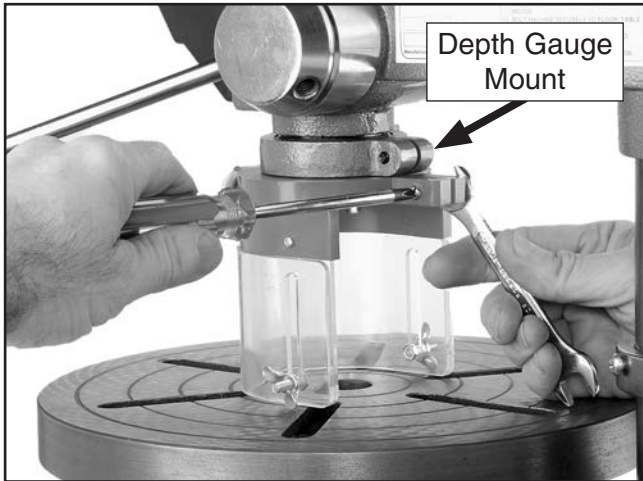

Figure 23. Installing chuck guard assembly.

- Thread handles into spindle hub, as shown in **Figure 24**, and tighten.
- Remove screw that fastens belt cover in place and replace with belt cover knob (see **Figure 24** for location).

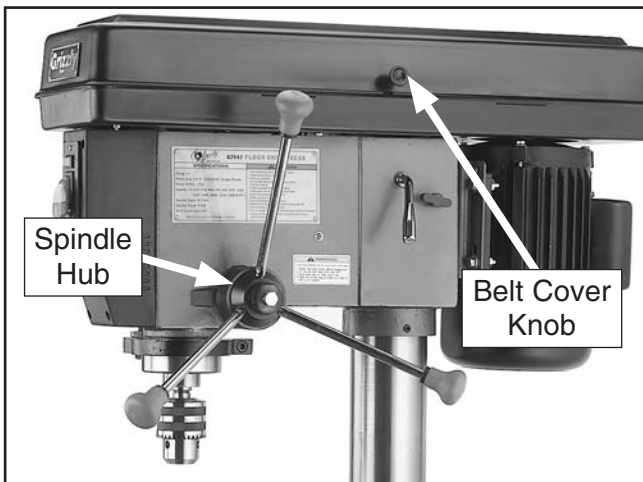

Figure 24. Downfeed handles and belt cover knob installed.

- Insert table shaft into table support assembly.

- Tighten small locking lever to secure table in table support assembly. The table should now be installed as shown in **Figure 25**.

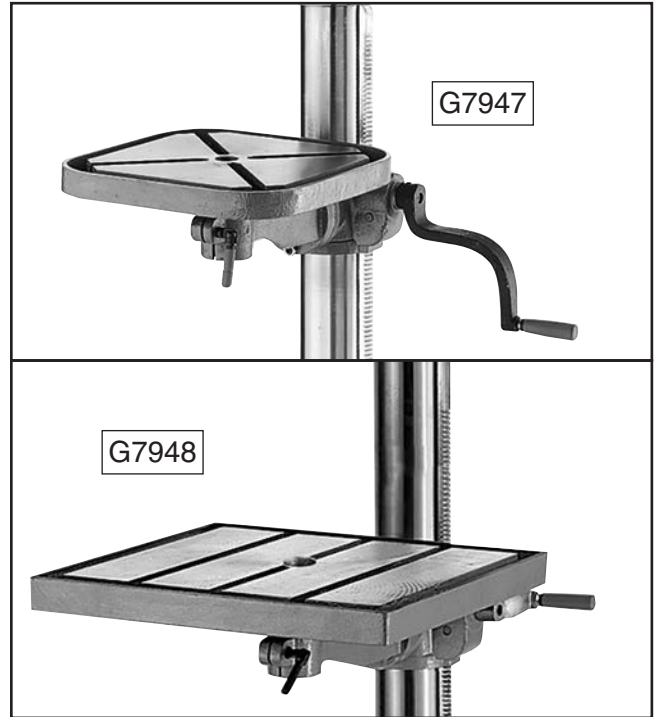

Figure 25. Tables installed.

⚠ CAUTION

Using light bulbs at 240V will cause bulbs to explode. The light socket is not wired or intended to be wired for 240V operation.

- Remove dust plug from light socket (120V operation only).
- Install a 60W or smaller light bulb in location shown in **Figure 26** (120V operation only).

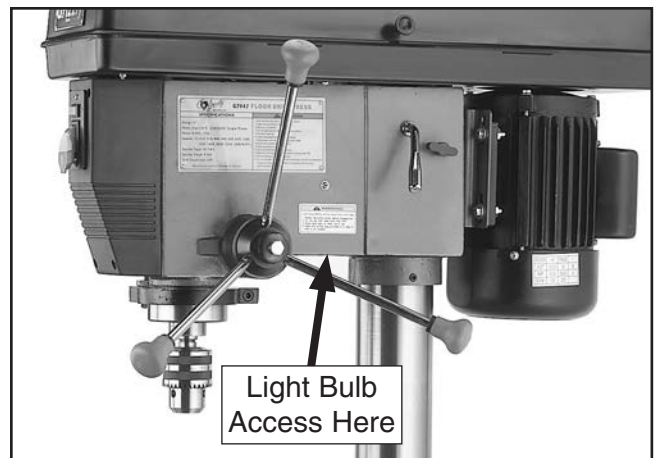

Figure 26. Light bulb access location.

Model G7947/G7948 (Mfd. Since 01/21)



Joining Drill Chuck & Arbor

An arbor is included for the drill chuck that comes with this machine. The following procedure describes how to install the arbor in the chuck.

After the arbor is installed in the drill chuck, it is very difficult to separate the assembly. If you would like to use a different chuck in the future, we recommend obtaining a new arbor.

IMPORTANT: DO NOT install the drill chuck and arbor assembly into the spindle until **AFTER** the test run.

To join drill chuck and arbor:

1. Use acetone or lacquer thinner to clean drill chuck and arbor mating surfaces, especially the bore.
2. Retract chuck jaws completely into chuck.
3. Insert small end of arbor into chuck.
4. Hold assembly by the arbor and tap chuck onto a block of wood with medium force, as illustrated below.

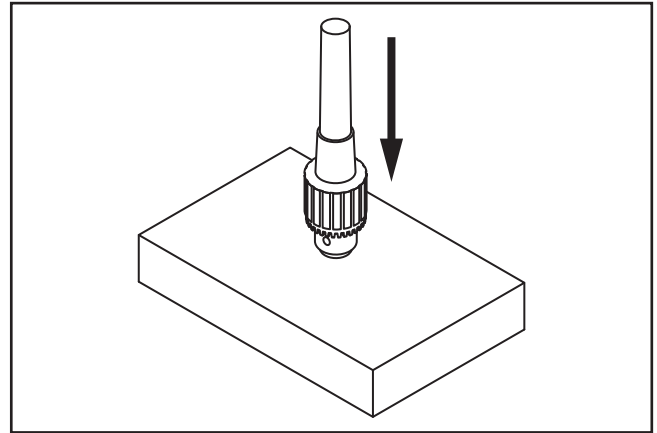

Figure 27. Tapping drill chuck/arbor on block of wood.

5. Attempt to separate drill chuck and arbor by hand—if they separate, repeat **Steps 3–4**.



Test Run

Once assembly is complete, test run the machine to ensure it is properly connected to power and safety components are functioning correctly.

If you find an unusual problem during the test run, immediately stop the machine, disconnect it from power, and fix the problem **BEFORE** operating the machine again. The **Troubleshooting** table in the **SERVICE** section of this manual can help.

The Test Run consists of verifying the following:

- 1) The motor powers up and runs correctly, and
- 2) the safety disabling mechanism on the switch works correctly.

⚠️ WARNING

Serious injury or death can result from using this machine BEFORE understanding its controls and related safety information. DO NOT operate, or allow others to operate, machine until the information is understood.

⚠️ WARNING

DO NOT start machine until all preceding setup instructions have been performed. Operating an improperly set up machine may result in malfunction or unexpected results that can lead to serious injury, death, or machine/property damage.

To test run the machine:

1. Clear all setup tools away from machine.
2. Connect machine to power supply.
3. Turn machine **ON**, verify motor operation, and then turn machine **OFF**.

The motor should run smoothly and without unusual problems or noises.

4. Remove switch disabling key, as shown in **Figure 28**.

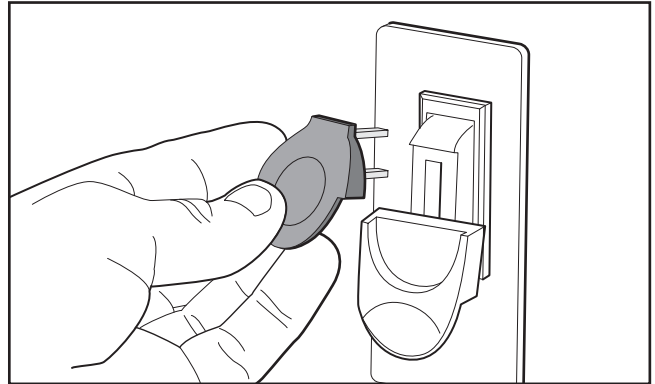
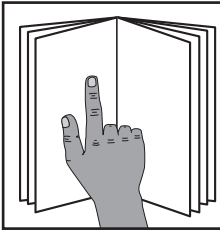

Figure 28. Removing switch key from paddle switch.

5. Try to start machine with paddle switch. The machine should not start.
 - If the machine *does not* start, the switch disabling feature is working as designed.
 - If the machine *does start*, immediately stop the machine. The switch disabling feature is not working correctly. This safety feature must work properly before proceeding with regular operations. Call Tech Support for help.



SECTION 4: OPERATIONS



!WARNING

To reduce your risk of serious injury, read this entire manual **BEFORE** using machine.

!WARNING

To reduce risk of eye injury from flying chips or lung damage from breathing dust, always wear safety glasses and a respirator when operating this machine.

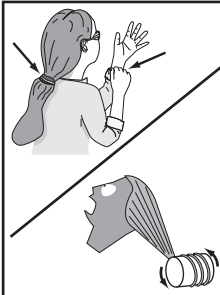
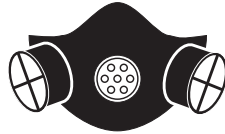

!WARNING

Keep hair, clothing, and jewelry away from moving parts at all times. Entanglement can result in death, amputation, or severe crushing injuries!

NOTICE

If you are not experienced with this type of machine, **WE STRONGLY RECOMMEND** that you seek additional training outside of this manual. Read books/magazines or get formal training before beginning any projects. Regardless of the content in this section, Grizzly Industrial will not be held liable for accidents caused by lack of training.

Operation Overview

The purpose of this overview is to provide the novice machine operator with a basic understanding of how the machine is used during operation, so the machine controls/components discussed later in this manual are easier to understand.

Due to the generic nature of this overview, it is **not** intended to be an instructional guide. To learn more about specific operations, read this entire manual, seek additional training from experienced machine operators, and do additional research outside of this manual by reading "how-to" books, trade magazines, or websites.

To complete a typical operation, the operator does the following:

1. Examines workpiece to make sure it is suitable for drilling.
2. Puts on required safety glasses and face shield.
3. Firmly secures workpiece to table using a vise or T-slot clamps.
4. Installs correct cutting tool for operation.
5. Adjusts table to correct height, then locks it in place.
6. Selects appropriate spindle speed according to V-belt configuration chart located inside belt cover.
7. Connects machine to power, and turns machine **ON**.
8. Begins drilling.
9. When finished, turns machine **OFF** and disconnects it from power.



Calculating Spindle Speed for Drilling

Using the Drill Bit Speed Chart

The chart shown in **Figure 29** is intended as a guide only. Always follow the manufacturer's speed recommendations if provided with your drill bits, cutters, or hole saws. Exceeding the recommended speeds may be dangerous to the operator.

The speeds shown here are intended to get you started. The optimum speed will always depend on various factors, including tool diameter, drilling pressure, material hardness, material quality, and desired finish.

Often, when drilling materials other than wood, some type of lubrication is necessary.

Lubrication Suggestions

WoodNone
 PlasticsSoapy Water
 BrassWater-Based Lubricant
 Aluminum..... Paraffin-Based Lubricant
 Mild Steel..... Oil-Based Lubricant

⚠ CAUTION

Larger bits turning at slower speeds tend to grab the workpiece aggressively. This can result in the operator's hand being pulled into the bit or the workpiece being thrown with great force. Always clamp the workpiece to the table to prevent injuries.

Twist/Brad Point Drill Bits	Soft Wood	Hard Wood	Plastic	Brass	Aluminum	Mild Steel
1/16" – 3/16"	3000	2500	2500	2500	3000	2500
13/64" – 3/8"	2000	1500	2000	1250	2500	1250
25/64" – 5/8"	1500	750	1500	750	1500	600
11/16" – 1"	750	500	1000	400	1000	350

Spade/Forstner Bits	Soft Wood	Hard Wood	Plastic	Brass	Aluminum	Mild Steel
1/4" – 1/2"	2000	1500	/	/	/	/
9/16" – 1"	1500	1250	/	/	/	/
1-1/8" – 1-7/8"	1000	750	/	/	/	/
2–3"	500	350	/	/	/	/

Hole Saws	Soft Wood	Hard Wood	Plastic	Brass	Aluminum	Mild Steel
1/2" – 7/8"	500	500	600	600	600	500
1" – 1-7/8"	400	400	500	500	500	400
2" – 2-7/8"	300	300	400	400	400	300
3" – 3-7/8"	200	200	300	300	300	200
4" – 5"	100	100	200	200	200	100

Rosette Cutters	Soft Wood	Hard Wood	Plastic	Brass	Aluminum	Mild Steel
Carbide Insert Type	350	250	/	/	/	/
One-Piece Type	1800	500	/	/	/	/

Tenon/Plug Cutters	Soft Wood	Hard Wood	Plastic	Brass	Aluminum	Mild Steel
3/8" – 1/2"	1200	1000	/	/	/	/
5/8" – 1"	800	600	/	/	/	/

Figure 29. Drill bit speed chart.



Changing Speeds

The Model G7947 & G7948 is capable of 12 different spindle speed RPMs. Spindle speed is controlled by the configuration of V-belts and pulleys located inside the belt cover on top of the machine.

To change speeds:

1. DISCONNECT MACHINE FROM POWER!
2. Loosen the belt tension lock knobs (shown in **Figure 30**) on both sides of the headstock, so the motor is free to move.

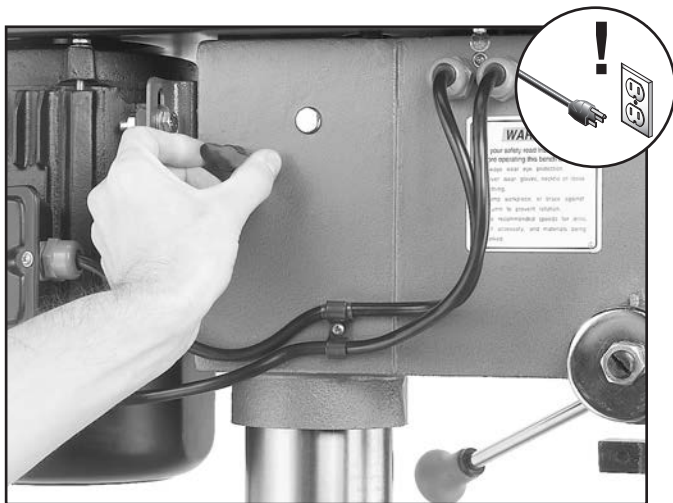

Figure 30. Loosening lock knob (both sides).

3. Rotate the belt tension lever clockwise, as shown in **Figure 31**, to take tension off the V-belts.



Figure 31. Using the belt tension lever.

4. Locate the desired speed on the speed chart under the belt cover and move the V-belts to the desired V-grooves on the motor, idler, and spindle pulleys.

For Example: As indicated in the speed chart for **670 RPM (Figure 32)**, a belt combination of **A-1.2-2** creates 670 RPM.

- The “**A-1**” refers to the belt position between the spindle pulley and the idler pulley.
- The “**2-2**” refers to the belt position between the motor pulley and the idler pulley.

Note: Both belts may have to be removed before certain speed changes can be made.

A-1.4-4	BELT:B-2.4-4	BELT:
630	⑥ RPM	670
⑦ RPM		
B-2.3-3	BELT:A-1.2-2	BELT:
1650	⑩ RPM	2050
		⑪ RPM

Figure 32. Pulley combination for 670 RPM for example.

5. Rotate the belt tension lever until the belts are tight. Tighten both lock knobs.
6. Close the cover before plugging in the machine.



Drilling

The Model G7947/G7948 is designed for drilling holes in wood or metal. The basic operation of a drill press is lining up your drill bit with the intended hole location, turning the drill press **ON**, and using the down feed levers to move the spinning drill bit into the workpiece.

For safe operation and optimum results, it is very important to follow these guidelines when drilling:

CLEARING CHIPS: Raise the drill bit often to clear chips and cool the drill bit. This will ease the work of the drill press motor and extend the life of your drill bits.

SECURING WORKPIECE TO TABLE: Secure the workpiece to the table or in a vise that is secured to the table before drilling.

PROTECTING TABLE: Protect the table by placing the workpiece on scrap wood, or center the location of the hole to be drilled over the pocket in the table when through drilling. Also, make use of the depth stop so that the drill bit goes no deeper than necessary.

USING CORRECT SPEEDS: Use the correct speed for the diameter of the drill bit being used and the type of material being drilled. Refer to the **Drill Bit Speed Chart** on **Page 39** to help you choose the correct speed for your application.

LARGE DIAMETER BITS: Large diameter drill bits require slower spindle speeds.

SMALL DIAMETER BITS: Smaller diameter drill bits require faster spindle speeds.

HARD MATERIAL: The harder the material, (steel vs. wood) the slower the spindle speed.

SOFT MATERIAL: The softer the material, the faster the spindle may turn. (Plastics can melt at too high of a spindle speed!)

LUBRICANT: Use some form of lubricant on all materials except wood. Refer to **Lubrication Suggestions** on **Page 28** to find the correct lubrication for your application.

DRILLING ACCURACY: To prevent drill bit wandering and ensure accurate placement of holes, mark the hole location with a center punch before drilling. Also consider using a center-point drill to start the hole.

PLUG/ROSETTE CUTTERS: Plug cutters and rosette cutters are for wood only. However, carbide-tipped bits and cutters cut at a higher speed and can cut materials other than wood, depending on the cutter type.

5-FLUTE/2-FLUTE CUTTERS: Use a 5-flute cutter when cutting into plastics, brass, aluminum, and mild steel. A 2-flute cutter can aggressively grab the workpiece and damage the tool if used with materials other than wood.

SPADE BITS AND PLASTIC: When drilling plastic with a spade bit, use a spade bit with spurs.

HOLE SAWS: When using hole saws, apply firm and even pressure, so the saw teeth contact the surface all at the same time—not at an angle. You can also flip the workpiece and finish drilling from the other side.

CAUTION

Larger bits turning at slower speeds tend to grab the workpiece aggressively. This can result in the operator's hand being pulled into the bit or the workpiece being thrown with great force. Always clamp the workpiece to the table to prevent injuries.



Installing/Removing Drill Bits

Any drill bit you install in the chuck must be tight enough that it will not come loose during operation.

To install a drill bit:

1. DISCONNECT MACHINE FROM POWER!
2. Open the drill chuck wide enough to accept the shank of the drill bit.
3. Insert the drill bit as far as possible into the chuck WITHOUT allowing the chuck jaws to touch the fluted portion of the bit, and hand tighten the chuck.

Note: Make sure small bits are not trapped between the edges of two jaws; if they are, reinstall the drill bit or it will not be secure enough to use for drilling.

4. Final tighten the drill bit with the chuck key.

To remove a drill bit:

1. DISCONNECT MACHINE FROM POWER!
2. Use the chuck key to open the drill chuck, and catch the drill bit with a rag to protect your hands.

Setting Depth Stop

The Model G7947/G7948 has a depth stop that allows you to drill repeated non-through holes to the same depth every time.

The depth stop consists of a stud attached to the quill with two hex nuts that can be lowered or raised on the stud so the lower nut (depth nut) hits a stop bracket when the drill bit is lowered. The upper hex nut (jam nut) is then used to tighten against the depth nut to secure it in place so it doesn't move with repeated operations. **Figure 33** shows the various components of the depth stop.

To set the depth stop:

1. Lower the drill bit to the required height.
2. Thread the depth nut down against the stop bracket (see **Figure 33**).

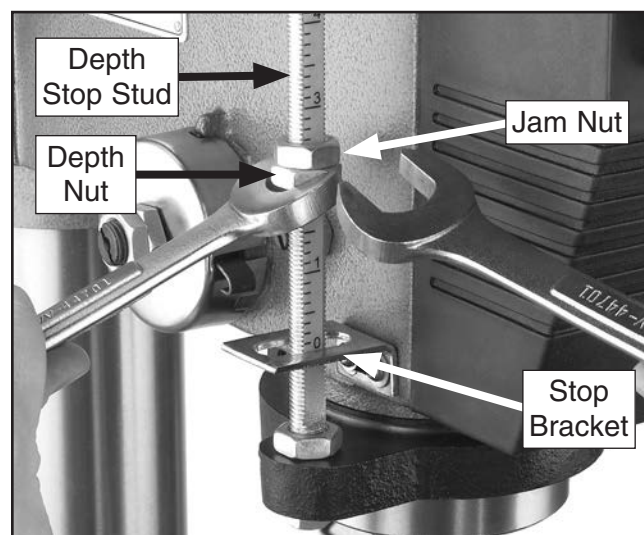

Figure 33. Depth-stop components.

3. Lower the jam nut against the depth nut.
4. Using wrenches, hold the depth nut in place and tighten the jam nut against the depth nut.

Note: The scale on the depth stop can be recalibrated if it gets moved or has changed since the factory setting. Refer to **Calibrating Depth Stop** on **Page 41** for instructions on how this is done.



Positioning Table

The table can be raised/lowered, rotated, and tilted 90° left or right. Table adjustment controls are shown in **Figure 34**.

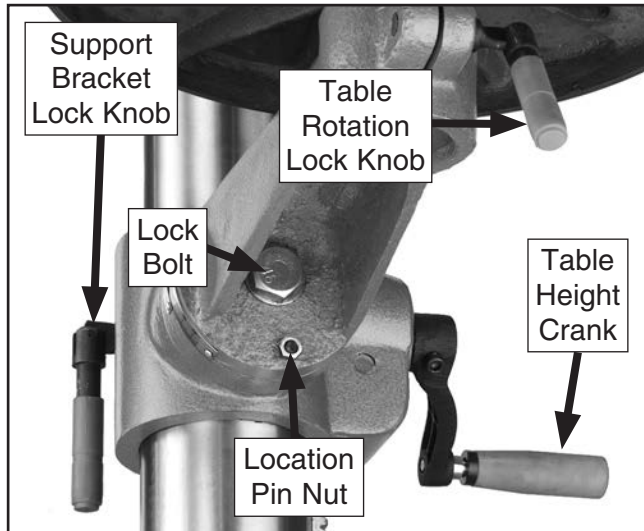

Figure 34. Table adjustment controls.

Table Height

1. Loosen the support bracket lock knob.
2. Adjust the height.
3. Lock the support bracket lock knob.

Table Rotation

1. Loosen the table rotation lock knob.
2. Rotate the table as necessary.
3. Lock the table rotation lock knob.

Table Tilt

1. Tighten the location pin nut to draw the location pin out of the hole.

Note: The location pin is friction fit in the hole to lock the table at 0°. When re-installing, set the table to 0°, back the nut off, and tap the pin back in the hole.

2. Loosen the lock bolt and tilt the table to the desired angle (make sure table rotation lock knob is locked, so the table won't fall out).
3. Tighten the lock bolt.



Removing Arbor

The arbor can be removed to install other Morse Taper tooling in the spindle. A drift key is included to help remove the arbor or other tooling from the spindle. Usually, once the chuck and arbor have been properly mounted together, they are considered semi-permanent connections. (If you would like to install a different chuck, we recommend getting a new arbor for that chuck.)

To remove the drill chuck and arbor:

1. DISCONNECT MACHINE FROM POWER!
2. Rotate the spindle handles until the drift-key slot is exposed in the side of the quill.
3. Rotate the depth stop hub clockwise until it stops.
4. Tighten the lock knob. The quill should not return up into the head casting when the depth stop is adjusted this way.
5. Rotate the spindle until the inner drift-key slot is aligned with the outer slot, as shown in **Figure 35**. You will see through the spindle when the slot is properly aligned.

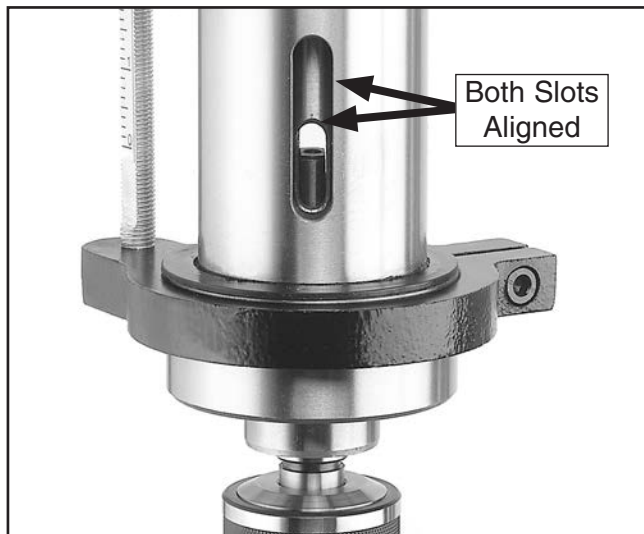

Figure 35. Inner and outer drift-key slots aligned.

6. Insert the drift key into the drift-key slot, and allow the quill to rise, trapping the drift key.

7. Hold the drill chuck with one hand, and tap on the drift key with a rubber or wooden mallet, as shown in **Figure 36**, until the chuck releases.



Figure 36. Using drift key to remove arbor.

8. Hold a downfeed handle with one hand, and loosen the depth stop lock with the other hand.
9. Carefully retract the quill into the head stock.



SECTION 5: ACCESSORIES

! WARNING

Installing unapproved accessories may cause machine to malfunction, resulting in serious personal injury or machine damage. To reduce this risk, only install accessories recommended for this machine by Grizzly.

NOTICE

Refer to our website or latest catalog for additional recommended accessories.

G2500—20-Pc. Regular Sanding Drum Set

Use on your drill press, lathe, or hand drill. This kit consists of 5 drums in popular 1/2" x 1/2", 3/4" x 1", 1" x 1", 1 1/2" x 1 1/2", and 2" x 1 1/2" sizes. Comes with 50, 80 and 120 grit sizes for each drum.



Figure 37. Model G2500 20-Pc. Sanding Drum Set.

G5753—Drill Press Vise 6"

If you use a drill press and value your fingers, you need one of these. Made from high-grade cast iron, these hefty horizontal vises offer support and stability, allowing you to keep your hands well away from fast moving bits and cutters.

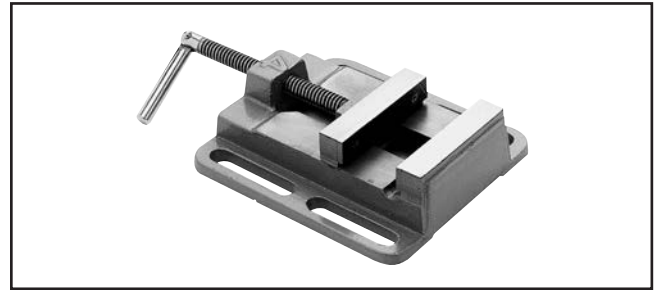

Figure 38. Model G5753 Drill Press Vise 6".

G5562—SLIPIT® 1 Qt. Gel

G5563—SLIPIT® 12 Oz. Spray

G2871—Boeshield® T-9 12 Oz. Spray

G2870—Boeshield® T-9 4 Oz. Spray

H3788—G96® Gun Treatment 12 Oz. Spray

H3789—G96® Gun Treatment 4.5 Oz. Spray



Figure 39. Recommended products for protecting unpainted cast-iron/steel areas.

order online at www.grizzly.com or call 1-800-523-4777



Basic Eye Protection

- T20501—Face Shield Crown Protector 4"
- T20502—Face Shield Crown Protector 7"
- T20503—Face Shield Window
- T20451—"Kirova" Clear Safety Glasses
- T20452—"Kirova" Anti-Reflective S. Glasses
- T20456—DAKURA Safety Glasses, Black/Clear



Figure 40. Assortment of basic eye protection.

- H2499—Small Half-Mask Respirator
- H3631—Medium Half-Mask Respirator
- H3632—Large Half-Mask Respirator
- H3635—Cartridge Filter Pair P100

Wood dust has been linked to nasal cancer and severe respiratory illnesses. If you work around dust everyday, a half-mask respirator can be a lifesaver. Also compatible with safety glasses!



Figure 41. Half-mask respirator with disposable cartridge filters.

D2139—Steelex® Cobalt Alloy Drill Bits 21-Pc. Set

Because of its resistance to heat and stress, Cobalt Alloy bits turn faster without overheating. The 135° split point enables the drill to use less thrust and eliminates the tendency of the drill point to walk, which makes these great for use in portable drills or drill presses. Cobalt Alloy bits will retain their edge sharpness longer than normal HSS bits, resulting in a significant saving of time and money in the workshop. Includes 1/16"- 3/8" bits and a heavy-gauge steel index case for storage.



Figure 42. Model D2139 21-Pc. Alloy Drill Bits.

T21992—Power Twist® V-Belt 1/2" x 48"

Smooth running with less vibration and noise than solid belts. The Power Twist® V-belts can be customized in minutes to any size—just add or remove sections to fit your needs. Size: 1/2" x 48"; replaces all "A" sized V-belts. Requires two Power Twist® V-belts to replace the stock V-belts on your Model G7947/G7948. Well worth it!

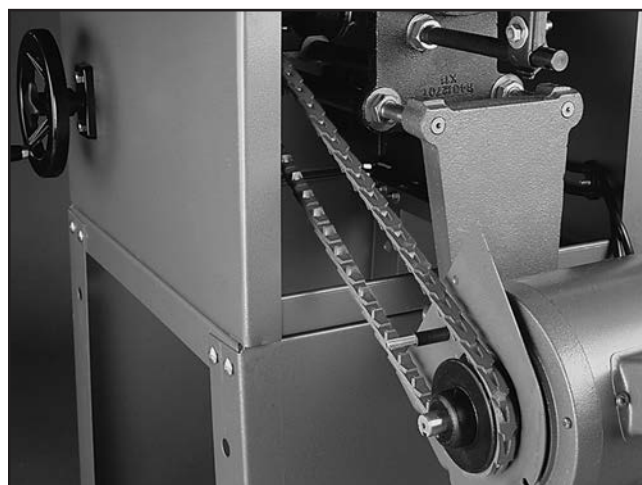

Figure 43. T21992 Power Twist® V-Belt installed.

order online at www.grizzly.com or call 1-800-523-4777



H7827—Drill Press Table

Add this 23³/₄" wide x 11⁷/₈" deep Drill Press Table with 3" high fence and stop block to your drill press for greater work support and increased accuracy. The fence and stop block slide along T-slots for quick, yet secure set-up and a removable 3¹⁵/₁₆" square center block allows thru drilling past the table. Fits all standard drill press tables and includes two universal table clamps. Mortising chisel and clamps not included.

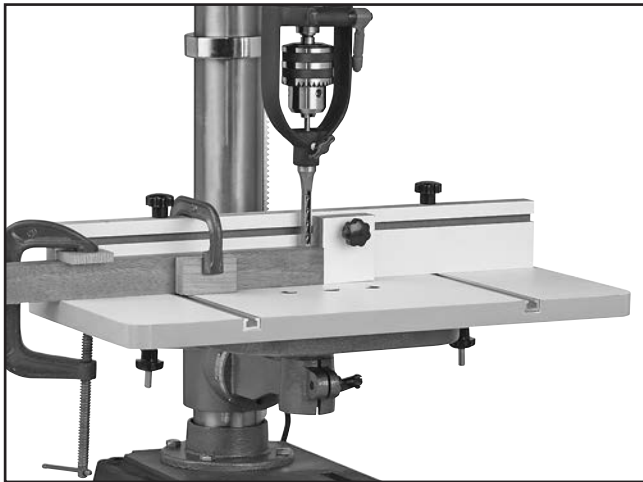

Figure 44. Model H7827 Drill Press Table.

H4978—Deluxe Earmuffs - 27dB

H4979—Twin Cup Hearing Protector - 29dB

T20446—Classic Earplugs, 200-pair - 31dB

Protect yourself comfortably with a pair of cushioned earmuffs. Especially important if you or employees operate for hours at a time.



Figure 45. Hearing protection.

D4088—Lathe Attachment for Drill Press

Perform vertical spindle turning on your multispeed drill press with this Lathe Attachment. Easy setup means quick change over from drill press mode to lathe mode. A 12" tool rest allows a maximum work piece length of 24" when the work piece is reversed. Includes a base plate with live center, 12" tool rest, mounting bolts, mini screw center and spur center. Fits all drill presses with a through hole in the table.



Figure 46. Model D4088 Lathe Attachment.

D3782—Lathe Chisel Set, 3-Pc.

This 3-Pc. Lathe Chisel Set will take care of most of your spindle turning operation needs. You get a 1/8" Parting Tool, 1/2" Skew Chisel, and 5/16" Spindle Gouge in a highly-protective aluminum case. HSS blades and ash handles will last a lifetime! Chisels measure 11⁵/₈" overall with 7⁷/₈" long handles.



Figure 47. Model D3782 Lathe Chisel Set, 3-Pc.

order online at www.grizzly.com or call 1-800-523-4777



H7789—Mortising Attachment

A mortising attachment and chisel lets you drill square holes in wood. The attachment holds the sharp cornered chisel in place while the inner drill cuts out the center. Drills have 1/2" shank. (For the G7947 & G7948 requires G9716 Quill Collar to work.)



Figure 48. H7789 Mortising Attachment.

H8196—3-Pc. Step Drill Set

These step drills are designed to incrementally drill through sheet metal and thin stock until reaching the desired hole size. Three step drills cover hole sizes from 1/8" to 1/2" in 1/32" increments, 3/16" to 1/2" in 1/16" increments, and 1/4" to 3/4" in 1/16" increments. No-slip shanks fit 3/8" chucks. Titanium nitride coated for long life.

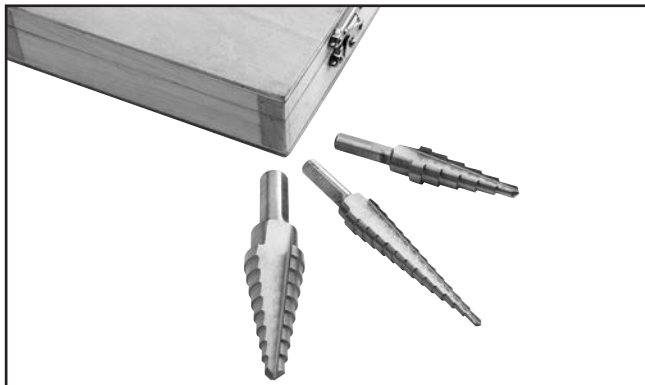

Figure 49. H8196 3-Pc. Step Drill Set

H8203—Professional Drill Bit Sharpening Machine (For Bits 1/8"–1/2" in Diameter)

This precision made Drill Bit Sharpening Machine is so simple to use, anyone can sharpen dull, smaller bits in three easy steps. Just set the drill bit in the collet, grind the taper relief angle, then grind the web thinning angle to reduce the center point width. It features a depth adjustment gauge, tapered diamond wheel, 90°–140° angle setting adjustment, and built-in collet tray. Collet sizes include 1/8", 5/32", 3/16", 1/4", 9/32", 5/16", 3/8", 25/64", 7/16", 15/32", and 1/2". Patented in the US!



Figure 50. H8203 Professional Drill Bit Sharpening Machine.

T10456—Heavy-Duty Anti-Fatigue Mat 3' x 5'

This Heavy-Duty Anti-Fatigue Mat features beveled edges and no-slip tread for safety and comfort. Open-hole design allows liquid to drain through, so it's perfect for wet or oily conditions. Measures 3' wide x 5' long x 3/8" thick.

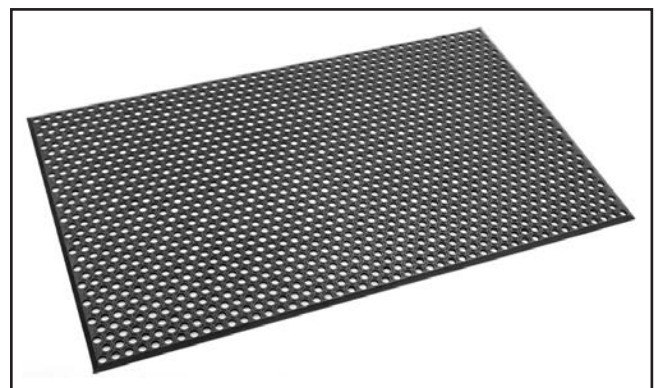
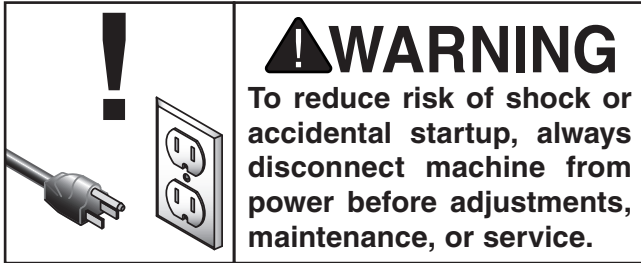

Figure 51. T10456 Heavy-Duty Anti-Fatigue Mat.

order online at www.grizzly.com or call 1-800-523-4777



SECTION 6: MAINTENANCE



General

For optimum performance from this machine, this maintenance schedule must be strictly followed.

Ongoing

To maintain a low risk of injury and proper machine operation, if you ever observe any of the items below, shut down the machine immediately and fix the problem before continuing operations:

- Loose mounting bolts.
- Worn switch.
- Worn or damaged wires.
- Damaged V-belts.
- Any other unsafe condition.

Monthly Check

- V-belt tension, damage, or wear.
- Clean/vacuum dust buildup off motor.

Cleaning & Protecting

Cleaning the Model G7947/G7948 is relatively easy. Vacuum excess wood chips and sawdust, and wipe off the remaining dust with a dry cloth. If any resin has built up, use a resin-dissolving cleaner to remove it.

Protect the unpainted cast-iron table by wiping it clean after every use—this ensures moisture from wood dust does not remain on bare metal surfaces. Keep the table rust-free with regular applications of products like G96® Gun Treatment, SLIPIT®, or Boeshield® T-9 (see **Page 34** for more details).

Lubrication

Since all bearings are shielded and permanently lubricated, simply leave them alone until they need to be replaced. DO NOT lubricate them.

Keep quill, spindle, column, and table top well lubricated to prevent rust.

V-Belts

Inspect regularly for tension and wear. Check pulleys to ensure that they are properly aligned. See **Changing Speeds** on **Page 29** for more information about removing/installing belts if you need help replacing the belts.



SECTION 7: SERVICE

Review the troubleshooting procedures in this section if a problem develops with your machine. If you need replacement parts or additional help with a procedure, call our Technical Support. **Note:** *Please gather the serial number and manufacture date of your machine before calling.*

Troubleshooting



Motor & Electrical

Symptom	Possible Cause	Possible Solution
Machine does not start or a breaker trips.	<ol style="list-style-type: none"> 1. Switch disabling key removed or at fault. 2. Incorrect power supply voltage or circuit size. 3. Power supply circuit breaker tripped or fuse blown. 4. Motor wires connected incorrectly. 5. Wiring open/has high resistance. 6. Start capacitor at fault. 7. Centrifugal switch at fault. 8. Motor at fault. 	<ol style="list-style-type: none"> 1. Insert disabling key or replace. 2. Ensure correct power supply voltage and circuit size. 3. Ensure circuit is sized correctly and free of shorts. Reset circuit breaker or replace fuse. 4. Correct motor wiring connections (Page 43). 5. Check/fix broken, disconnected, or corroded wires. 6. Test/replace. 7. Adjust/replace centrifugal switch if available. 8. Test/repair/replace.
Machine stalls or is underpowered.	<ol style="list-style-type: none"> 1. Incorrect/dull cutter/bit for task. 2. Feed rate/cutting speed too fast. 3. Belt(s) slipping. 4. Machine undersized for task. 5. Motor overheated. 6. Pulley slipping on shaft. 7. Centrifugal switch at fault. 8. Motor at fault. 	<ol style="list-style-type: none"> 1. Use correct cutter/bit. 2. Decrease feed rate/cutting speed (Page 29). 3. Ensure belts are oil free, tension/replace belt(s); ensure pulleys are aligned. 4. Perform operation with different machine. 5. Clean motor, let cool, and reduce workload. 6. Tighten loose pulley; replace broken/missing parts. 7. Adjust/replace centrifugal switch if available. 8. Test/repair/replace.
Machine has vibration or noisy operation.	<ol style="list-style-type: none"> 1. Motor or other drive component loose. 2. V-belt(s) worn or loose. 3. Motor fan rubbing on fan cover. 4. Pulley loose. 5. Motor mount loose/broken. 6. Motor or spindle bearings at fault. 7. Chuck unbalanced or cutter dull. 	<ol style="list-style-type: none"> 1. Inspect/replace damaged bolts/nuts, and retighten with thread locking fluid, if necessary. 2. Inspect/replace belts with a new matched set (Page 29). 3. Fix/replace fan cover; replace loose/damaged fan. 4. Re-align/replace shaft, pulley set screw, and key. 5. Tighten/replace. 6. Test by rotating shaft; rotational grinding/loose shaft requires bearing replacement. 7. Replace chuck; replace/resharpen cutter.



Drill Press Operations

Symptom	Possible Cause	Possible Solution
Tool loose/lack of power in spindle.	<ol style="list-style-type: none"> 1. Tool incorrectly installed in spindle taper. 2. Debris on tool or spindle taper mating surfaces. 3. Taking too big of a cut. 4. V-belts are loose. 5. Wrong voltage. 	<ol style="list-style-type: none"> 1. Remove and re-install (Page 33). 2. Clean tool and spindle taper. 3. Lessen depth of cut and allow chips to clear (Page 30). 4. Properly tension V-belts (Page 29). 5. Correct voltage.
Workpiece or tool vibrates or chatters during operation.	<ol style="list-style-type: none"> 1. Table locks not tight. 2. Workpiece not secure. 3. Spindle speed/feed rate is too fast. 4. Spindle or quill extended too far down. 	<ol style="list-style-type: none"> 1. Tighten table locks (Page 32). 2. Properly clamp workpiece on table or in vise. 3. Set spindle speed correctly (Page 29) or use slower feed rate. 4. Fully retract spindle and lower headstock. This increases rigidity to decrease vibration.
Headstock is hard to raise.	<ol style="list-style-type: none"> 1. Headstock lock nuts at fault. 2. Rack and pinion at fault or jammed with grime/debris. 	<ol style="list-style-type: none"> 1. Loosen/replace lock nuts. 2. Fix/replace broken or loose parts; clean and lubricate rack and pinion.
Bad surface finish.	<ol style="list-style-type: none"> 1. Spindle speed too fast for workpiece material. 2. Dull or incorrect cutting tool. 3. Wrong rotation direction of cutting tool. 4. Workpiece not secure. 5. Spindle extended too far down during operation. 	<ol style="list-style-type: none"> 1. Set spindle speed correctly (Page 29). 2. Sharpen cutting tool or select one that better suits the operation. 3. Check for proper cutting tool rotation. 4. Properly clamp workpiece on table or in vise. 5. Fully retract spindle and lower headstock. This increases rigidity.
Spindle overheats.	<ol style="list-style-type: none"> 1. Drill operated at high speeds for extended period. 	<ol style="list-style-type: none"> 1. Allow drill to cool.
Spindle does not return to highest position.	<ol style="list-style-type: none"> 1. Poorly adjusted return spring. 2. Worn return spring. 	<ol style="list-style-type: none"> 1. Increase return spring tension (Page 41). 2. Replace return spring.
Depth stop producing inaccurate results.	<ol style="list-style-type: none"> 1. Depth stop not calibrated. 	<ol style="list-style-type: none"> 1. Calibrate depth stop (Page 41).



Calibrating Depth Stop

The drill press comes fitted with a depth stop to use when drilling multiple holes at the same depth. The scale on this depth stop can be calibrated if it ever becomes incorrect.

To calibrate the depth stop:

1. Loosen the jam nut and calibration nut shown in **Figure 52**.

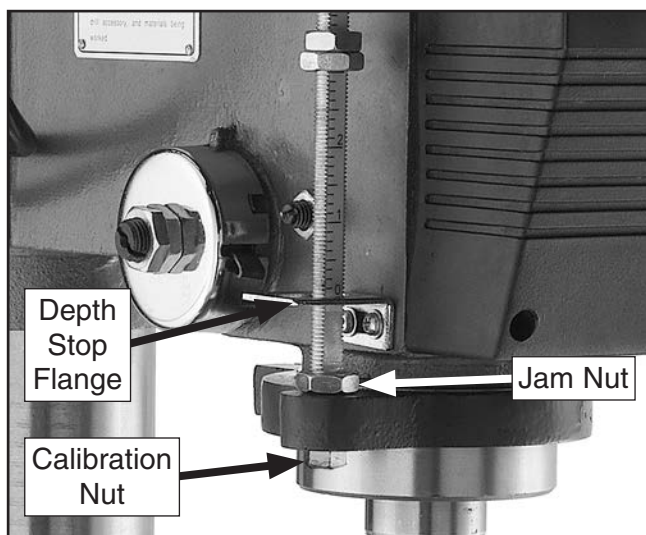

Figure 52. Depth stop assembly.

2. Use the calibration nut to zero the depth stop scale with the depth stop flange.
3. Hold the depth stop at zero, and tighten the jam nut to hold the depth stop in position.
4. Test the depth stop by measuring how far the spindle actually moves with respect to where you set the depth stop.

Tensioning Spindle Return Spring

The tension of the spindle return spring makes the spindle automatically return to the top (starting) position when the downfeed handle is released. This spring is pre-adjusted at the factory, and typically will never need further adjustment during the life of the drill press. However, additional tension can be applied if the spindle stops automatically returning to the top position.



Items Needed	Qty
Heavy Leather Gloves	1 Pr
Shop Rags.....	As Needed
Open-End Wrench 24mm.....	1

To adjust the feed shaft spring tension:

1. DISCONNECT MACHINE FROM POWER!
2. Wipe off any oil on the spring lock cover so it does not slip in your fingers when you hold the cover from spinning (see **Figure 53**).

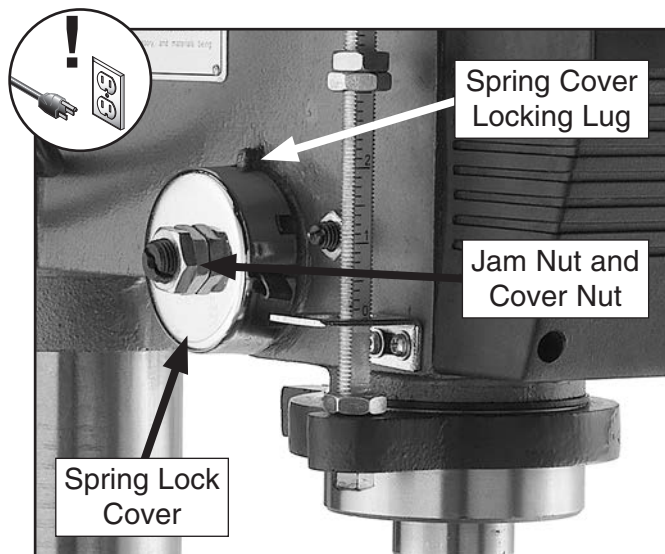

Figure 53. Feed shaft return spring assembly.



3. While holding the spring lock cover against the side of the headstock so the cover stays splined with the locking lug, as shown in **Figure 54**, loosen the jam nut and loosen the cover nut approximately $\frac{1}{4}$ " each.

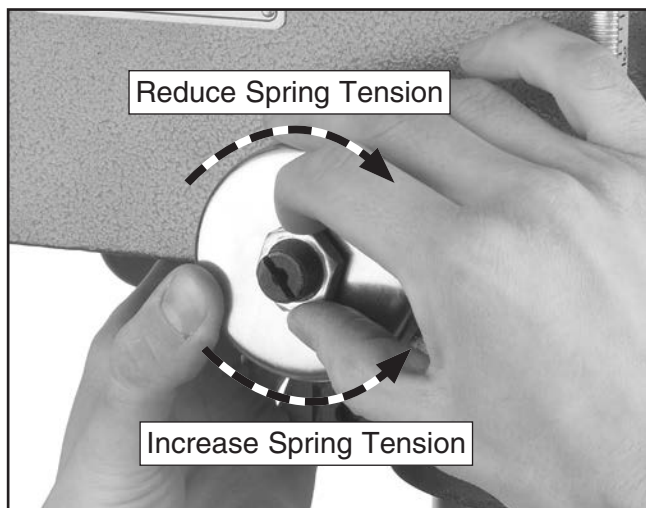

Figure 54. Loosening cover and jam nut to adjust return spring tension.

⚠ CAUTION

A high-tension coiled spring is underneath the cover. Put on heavy leather gloves to protect your hands from possible lacerations when removing the cover.

4. Put on heavy leather gloves to protect your hands from possible lacerations if the spring uncoils during the next step.
5. Pull the cover outward just enough to disengage the spring-cover lock slot from the locking lug.

CAUTION: *It is important to keep a good grip during this step. Letting go of the cover will cause the spring to rapidly uncoil.*

6. Rotate the cover counterclockwise to increase spring tension, or let the cover slowly unwind in the clockwise direction to reduce spring tension (see **Figure 54**).
7. Engage the next available spring-cover lock slot with the locking lug and hold the spring lock cover tightly against the side of the headstock.
8. Snug the cover nut against the spring cover just until the nut stops, and then back off the nut approximately $\frac{1}{3}$ turn, or just enough so there is no binding at complete spindle travel.
9. Hold the cover nut and tighten the jam nut against the cover nut.



SECTION 8: WIRING

These pages are current at the time of printing. However, in the spirit of improvement, we may make changes to the electrical systems of future machines. Compare the manufacture date of your machine to the one stated in this manual, and study this section carefully.

If there are differences between your machine and what is shown in this section, call Technical Support at (570) 546-9663 for assistance BEFORE making any changes to the wiring on your machine. An updated wiring diagram may be available. **Note:** *Please gather the serial number and manufacture date of your machine before calling. This information can be found on the main machine label.*

WARNING

Wiring Safety Instructions

SHOCK HAZARD. Working on wiring that is connected to a power source is extremely dangerous. Touching electrified parts will result in personal injury including but not limited to severe burns, electrocution, or death. Disconnect the power from the machine before servicing electrical components!

MODIFICATIONS. Modifying the wiring beyond what is shown in the diagram may lead to unpredictable results, including serious injury or fire. This includes the installation of unapproved after-market parts.

WIRE CONNECTIONS. All connections must be tight to prevent wires from loosening during machine operation. Double-check all wires disconnected or connected during any wiring task to ensure tight connections.

CIRCUIT REQUIREMENTS. You MUST follow the requirements at the beginning of this manual when connecting your machine to a power source.

WIRE/COMPONENT DAMAGE. Damaged wires or components increase the risk of serious personal injury, fire, or machine damage. If you notice that any wires or components are damaged while performing a wiring task, replace those wires or components.

MOTOR WIRING. The motor wiring shown in these diagrams is current at the time of printing but may not match your machine. If you find this to be the case, use the wiring diagram inside the motor junction box.















CAPACITORS/INVERTERS. Some capacitors and power inverters store an electrical charge for up to 10 minutes after being disconnected from the power source. To reduce the risk of being shocked, wait at least this long before working on capacitors.

EXPERIENCING DIFFICULTIES. If you are experiencing difficulties understanding the information included in this section, contact our Technical Support at (570) 546-9663.

NOTICE

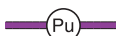
The photos and diagrams included in this section are best viewed in color. You can view these pages in color at www.grizzly.com.

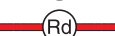
COLOR KEY

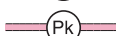
BLACK		BLUE		YELLOW		LIGHT BLUE	
WHITE		BROWN		YELLOW GREEN		BLUE WHITE	
GREEN		GRAY		PURPLE		TURQUOISE	
RED		ORANGE		PINK			



Electrical Components

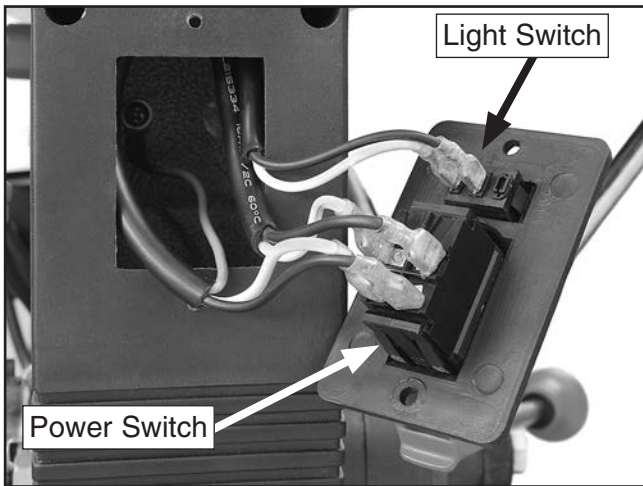

Figure 55. Power and light switch assembly.

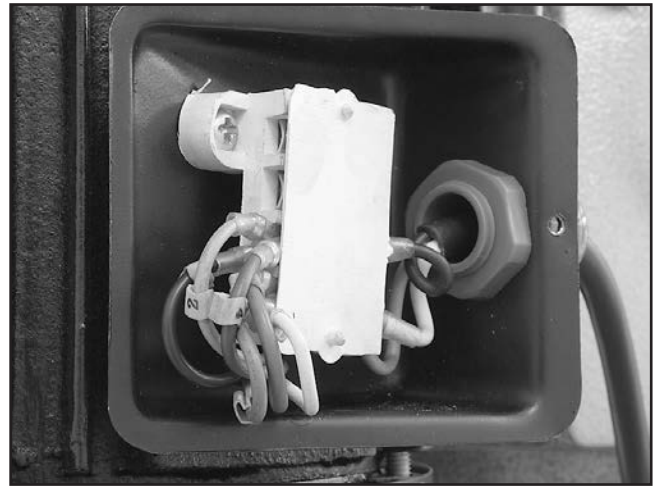

Figure 57. Motor wiring inside junction box.



Figure 56. Light socket with dust plug removed (for 120V operation only).



G7947/G7948 Wiring Diagram

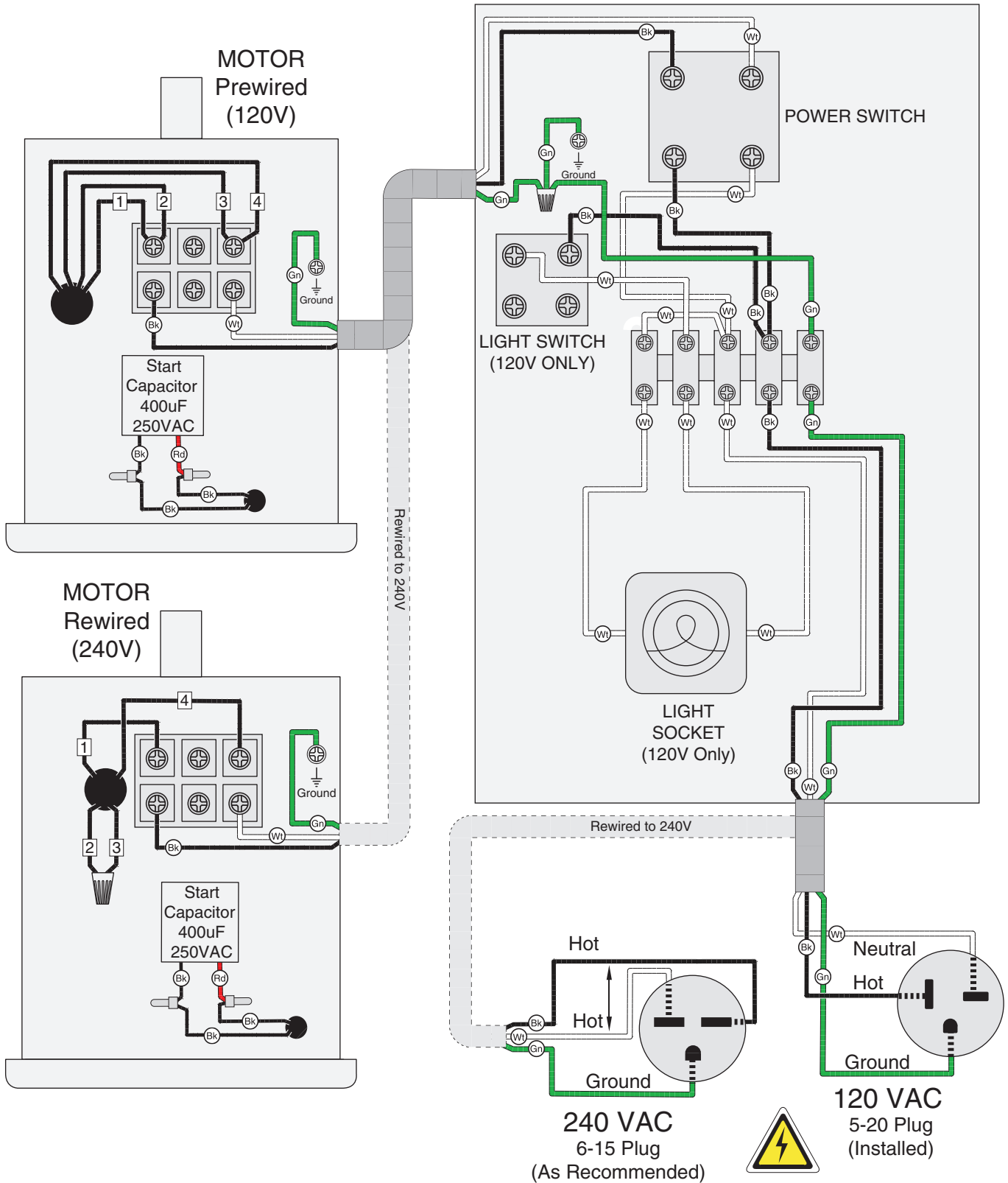

SECTION 9: PARTS

G7947 Stand & Table Breakdown

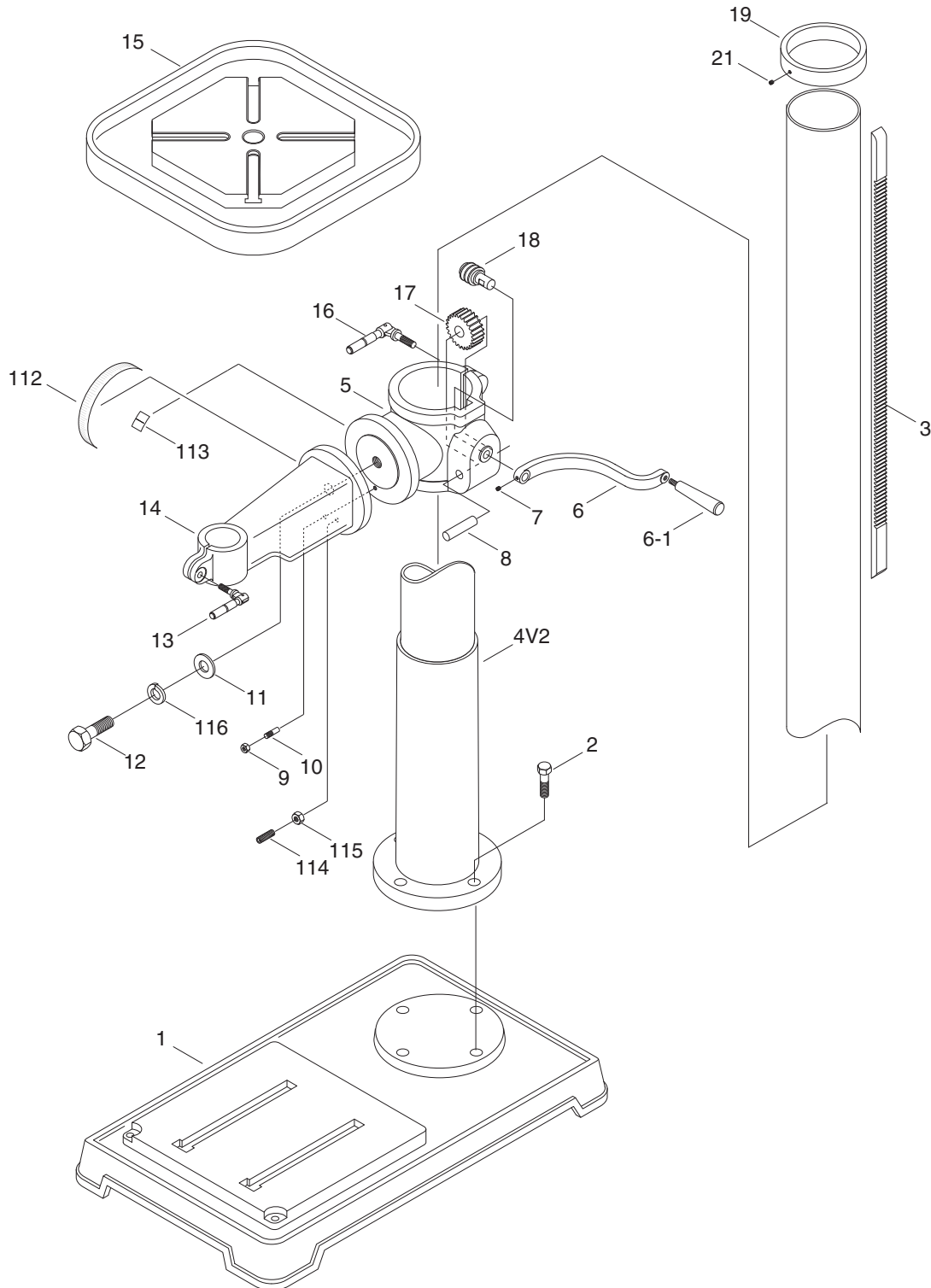

We do our best to stock replacement parts when possible, but we cannot guarantee that all parts shown are available for purchase. Call **(800) 523-4777** or visit **www.grizzly.com/parts** to check for availability.



G7947 Headstock Breakdown

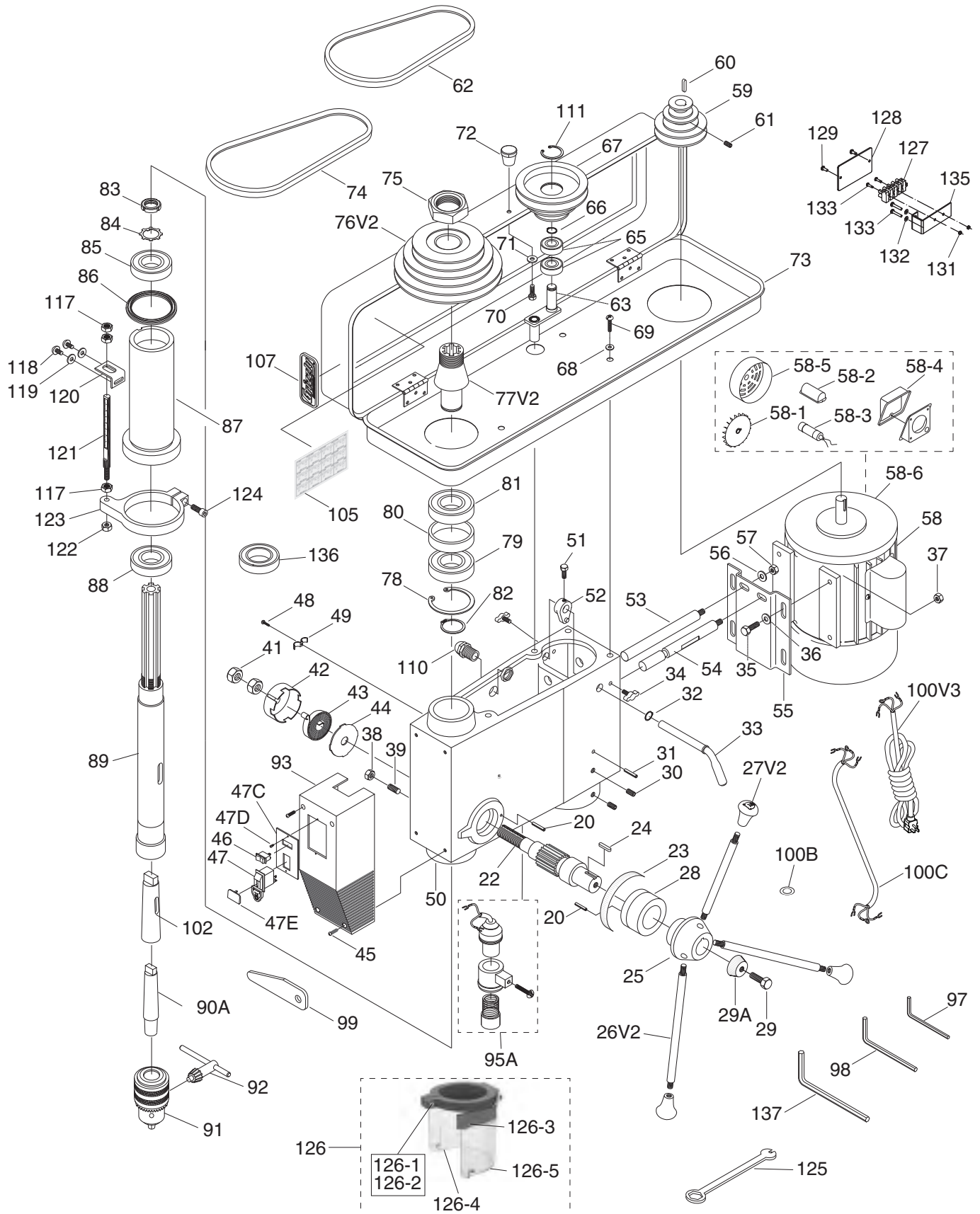

G7947 Parts List

REF	PART #	DESCRIPTION
1	P7947001	BASE
2	P7947002	HEX BOLT M12-1.75 X 40
3	P7947003	RACK
4V2	P7947004V2	COLUMN 7-1/4 IN V2.09.05
5	P7947005	TABLE BRACKET
6	P7947006	HANDLE ARM
6-1	P7947006-1	HANDLE
7	P7947007	SET SCREW M8-1.25 X 10
8	P7947008	SHAFT
9	P7947009	HEX NUT M6-1
10	P7947010	TABLE PIN
11	P7947011	FLAT WASHER 20MM
12	P7947012	HEX BOLT M20-2.5 x 45
13	P7947013	LOCK KNOB M10-1.5 X 30
14	P7947014	TABLE ARM BRACKET
15	P7947015	TABLE
16	P7947016	LOCK KNOB
17	P7947017	GEAR 14T
18	P7947018	WORM GEAR
19	P7947019	RACK RING
20	P7947020	ROLL PIN 4 X 20
21	P7947021	SET SCREW M6-1.0 X 10
22	P7947022	FEED SHAFT
23	P7947023	SCALE RING
24	P7947024	KEY 6 X 6 X 20
25	P7947025	HANDLE BODY
26V2	P7947026V2	HANDLE V2.02.99
27V2	P7947027V2	KNOB M12-1.75 V2.02.99
28	P7947028	FEED SHAFT CONNECTOR
29	P7947029	HEX BOLT M10-1.5 X 30
29A	P7947029A	PLASTIC LOCK CAP
30	P7947030	SET SCREW M10-1.5 X 10
31	P7947031	ROLL PIN 8 X 25
32	P7947032	EXT RETAINING RING 16MM
33	P7947033	SHIFTER BAR
34	P7947034	SLIDE BAR BOLT M10-1.5 X 35
35	P7947035	HEX BOLT M8-1.25 X 30
36	P7947036	FLAT WASHER 8MM
37	P7947037	HEX NUT M8-1.25
38	P7947038	HEX NUT M10-1.5
39	P7947039	SET SCREW M10-1.5 X 30
41	P7947041	HEX NUT M16-1.5 THIN
42	P7947042	SPRING CAP
43	P7947043	TORSION SPRING
44	P7947044	SPRING COVER
45	P7947045	PHLP HD SCR M5-.8 X 14
46	P7947046	LIGHT SWITCH
47	P7947047	GRIZZLY SAFETY PADDLE SWITCH
47C	P7947047C	SWITCH PLATE
47D	P7947047D	TAP SCREW M4 X 12

REF	PART #	DESCRIPTION
47E	P7947047E	YELLOW SWITCH KEY
48	P7947048	PHLP HD SCR M5-.8 X 10
49	P7947049	CORD CLAMP
50	P7947050	HEAD CASTING
51	P7947051	HEX BOLT M8-1.25 X 16
52	P7947052	SHIFTER
53	P7947053	LEFT SLIDE BAR
54	P7947054	RIGHT SLIDE BAR
55	P7947055	MOTOR BASE
56	P7947056	FLAT WASHER 12MM
57	P7947057	HEX NUT M12-1.75
58	P7947058	MOTOR 1-1/2HP 120/240V 1PH
58-1	P7947058-1	MOTOR FAN
58-2	P7947058-2	CAPACITOR COVER
58-3	P7947058-3	S CAPACITOR 400M 250V
58-4	P7947058-4	MOTOR JUNCTION BOX
58-5	P7947058-5	MOTOR FAN COVER
58-6	P7947058-6	CAST IRON END BELL FOR MOTOR
59	P7947059	MOTOR PULLEY
60	P7947060	KEY 5 X 5 X 25
61	P7947061	SET SCREW M6-1 X 10
62	P7947062	V-BELT A-27 4L290
63	P7947063	CENTER SHAFT
65	P7947065	BALL BEARING 6202 ZZ
66	P7947066	EXT RETAINING RING 15MM
67	P7947067	CENTER PULLEY
68	P7947068	FLAT WASHER 8MM
69	P7947069	PHLP HD SCR M8-1.25 X 12
70	P7947070	PHLP HD SCR M5-.8 X 10
71	P7947071	FLAT WASHER 5MM
72	P7947072	PULLEY COVER KNOB
73	P7947073	PULLEY HOUSING 8-1/4 X 28-1/2"
74	P7947074	V-BELT A31
75	P7947075	PULLEY NUT
76V2	P7947076V2	SPINDLE PULLEY V2.02.99
77V2	P7947077V2	INSERT PULLEY V2.02.99
78	P7947078	INT RETAINING RING 72MM
79	P7947079	BALL BEARING 6207ZZ
80	P7947080	SPACER
81	P7947081	BALL BEARING 6207ZZ
82	P7947082	EXT RETAINING RING 35MM
83	P7947083	SPANNER NUT
84	P7947084	TAB WASHER 8107
85	P7947085	BALL BEARING 6206ZZ
86	P7947086	RUBBER WASHER
87	P7947087	QUILL
88	P7947088	BALL BEARING 6207ZZ
89	P7947089	SPINDLE
90A	P7947090A	DRILL CHUCK ARBOR MT3 X JT3
91	P7947091	DRILL CHUCK JT3 X 3/64-5/8"



G7947 Parts List (Cont.)

REF	PART #	DESCRIPTION
92	P7947092	CHUCK KEY
93	P7947093	SWITCH BOX
95A	P7947095A	LIGHT SOCKET ASSY.
97	P7947097	HEX WRENCH 3MM
98	P7947098	HEX WRENCH 4MM
99	P7947099	DRIFT KEY
100V3	P7947100V3	POWER CORD 14G 3W 72" 5-20P V3.01.21
100B	P7947100B	WIRE GASKET
100C	P7947100C	MOTOR CORD
102	P7947102	SLEEVE MT#2/3
105	P7947105	SPEED CHART
107	P7947107	GRIZZLY BLACK/AL LABEL
110	P7947110	STRAIN RELIEF
111	P7947111	INT RETAINING RING 35MM
112	P7947112	DEGREE SCALE
113	P7947113	INDICATOR
114	P7947114	SET SCREW M10-1.5 X 28
115	P7947115	HEX NUT M10-1.5
116	P7947116	LOCK WASHER 20MM
117	P7947117	HEX NUT M12-1.5
118	P7947118	PHLP HD SCR M5-.8 X 10
119	P7947119	FLAT WASHER 5MM

REF	PART #	DESCRIPTION
120	P7947120	DEPTH STOP BRACKET
121	P7947121	DEPTH STOP SCALE STUD
122	P7947122	HEX NUT M8-1.25
123	P7947123	QUILL CLAMP
124	P7947124	CAP SCREW M8-1.25 X 20
125	P7947125	FLAT LOCK WRENCH 12/30MM
126	P7947126	CHUCK GUARD ASSEMBLY
126-1	P7947126-1	PHLP HD SCR M4-.7 X 30
126-2	P7947126-2	HEX NUT M4-.7
126-3	P7947126-3	TAP SCREW M2.2 X 4.5
126-4	P7947126-4	HEX BOLT M5-.8 X 12
126-5	P7947126-5	WING NUT M5-.8
127	P7947127	TERMINAL BAR
128	P7947128	METAL COVER
129	P7947129	PHLP HD SCR M4-.7 X 10
131	P7947131	HEX NUT M4-.7
132	P7947132	FLAT WASHER 4MM
133	P7947133	PHLP HD SCR M4-.7 X 20
135	P7947135	SUPPORT PLATE
136	P7947136	THRUST BEARING 51107
137	P7947137	HEX WRENCH 5MM

WARNING

Safety labels help reduce the risk of serious injury caused by machine hazards. If any label comes off or becomes unreadable, the owner of this machine **MUST** replace it in the original location before resuming operations. For replacements, contact (800) 523-4777 or www.grizzly.com.



G7948 Stand & Table Breakdown

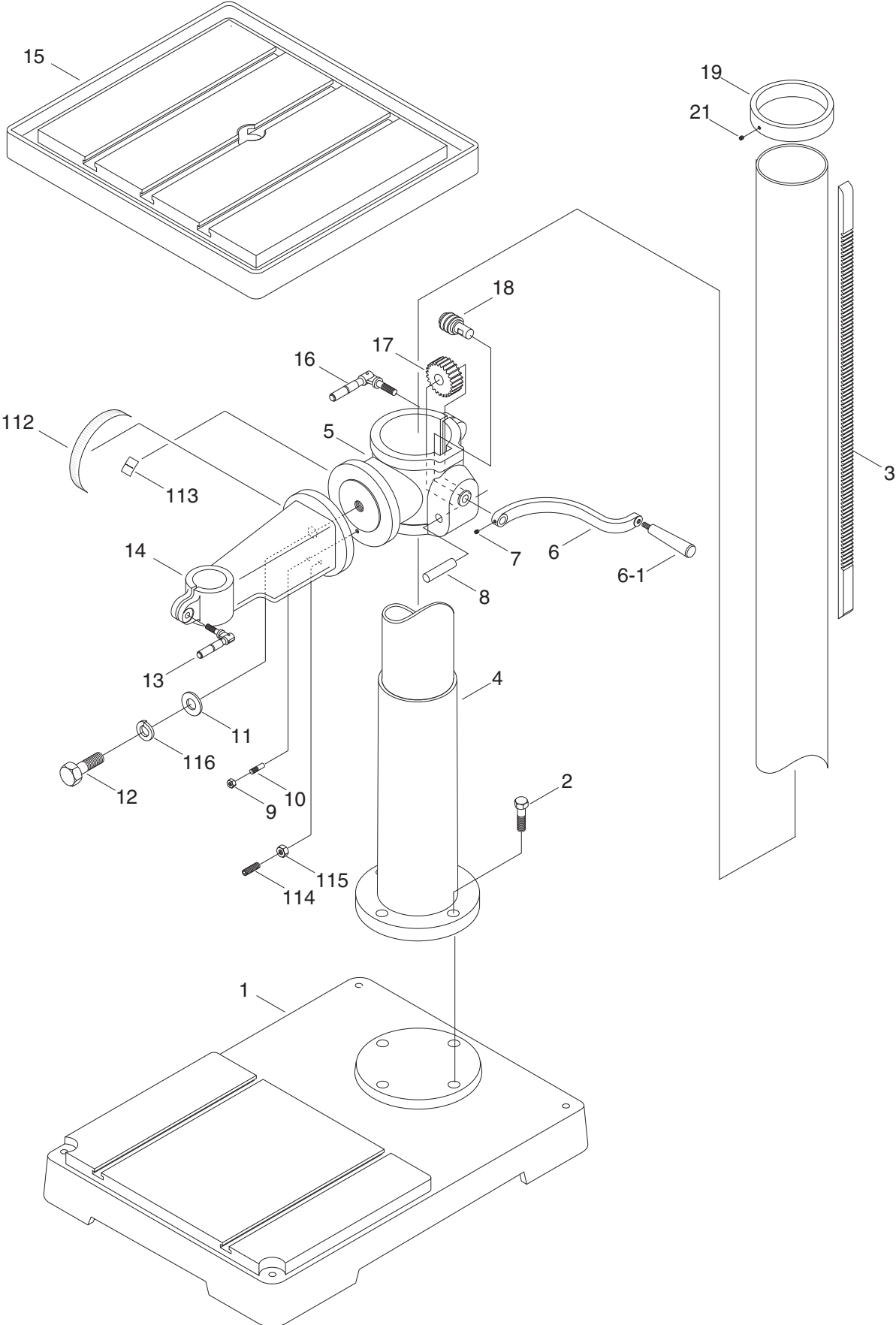

G7948 Headstock Breakdown

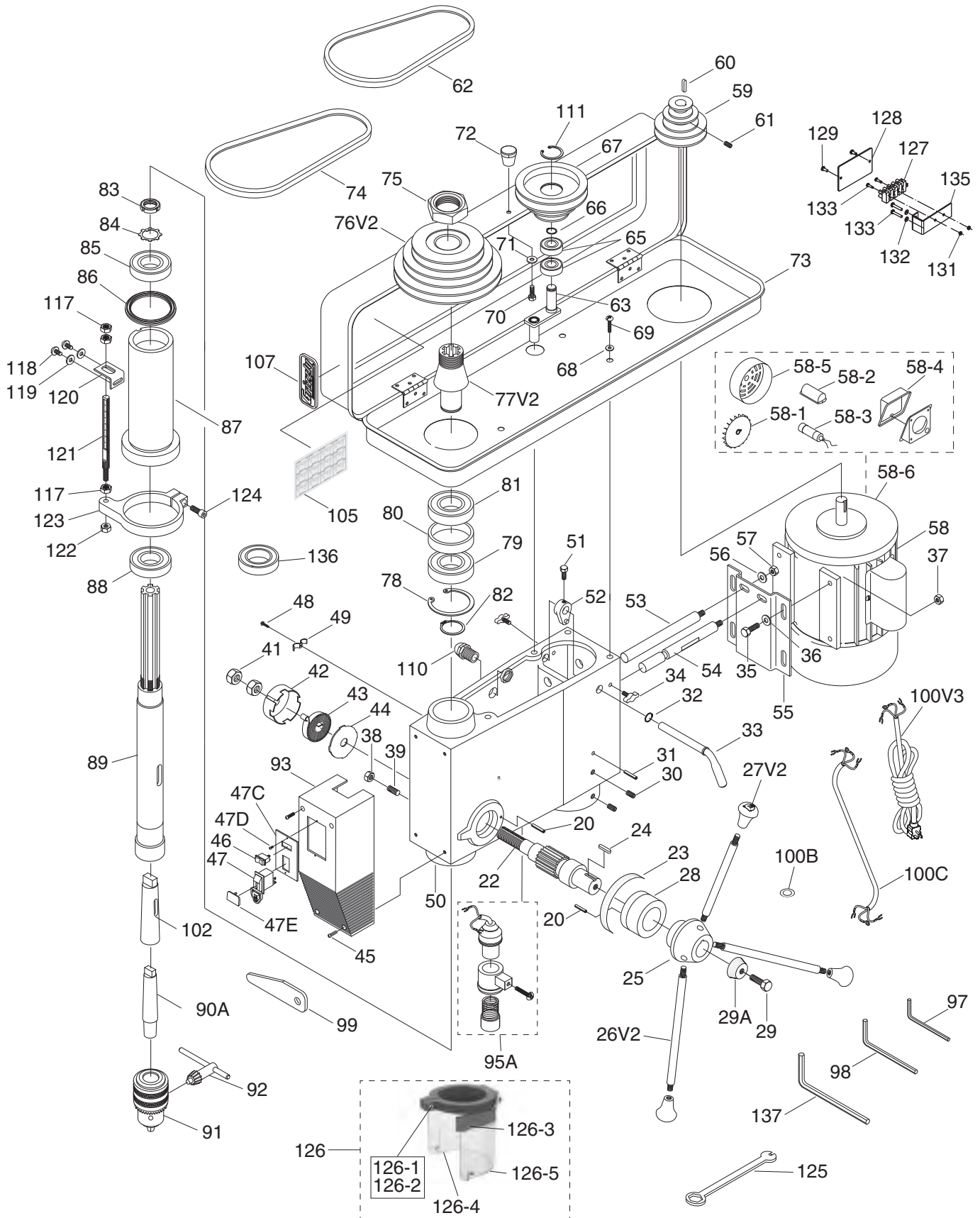

G7948 Parts List

REF	PART #	DESCRIPTION
1	P7948001	BASE
2	P7948002	HEX BOLT M12-1.75 X 40
3	P7948003	RACK
4	P7948004	COLUMN
5	P7948005	TABLE BRACKET
6	P7948006	HANDLE ARM
6-1	P7948006-1	HANDLE
7	P7948007	SET SCREW M8-1.25 X 10
8	P7948008	SHAFT
9	P7948009	HEX NUT M6-1 X 30
10	P7948010	TABLE PIN
11	P7948011	FLAT WASHER 20MM
12	P7948012	HEX BOLT M20-2.5 X 45
13	P7948013	LOCK KNOB M10-1.5 X 30
14	P7948014	TABLE ARM BRACKET
15	P7948015	TABLE
16	P7948016	LOCK KNOB
17	P7948017	GEAR 14T
18	P7948018	WORM GEAR
19	P7948019	RACK RING
20	P7948020	ROLL PIN 4 X 20
21	P7948021	SET SCREW M6-1 X 10
22	P7948022	FEED SHAFT
23	P7948023	SCALE RING
24	P7948024	KEY 6 X 6 X 20
25	P7948025	HANDLE BODY
26V2	P7948026V2	HANDLE V2.02.99
27V2	P7948027V2	KNOB M12-1.75 V2.02.99
28	P7948028	FEED SHAFT CONNECTOR
29	P7948029	HEX BOLT M10-1.5 X 30
29A	P7948029A	PLASTIC LOCK CAP
30	P7948030	SET SCREW M10-1.5 X 10
31	P7948031	ROLL PIN 8MM
32	P7948032	EXT RETAINING RING 16MM
33	P7948033	SHIFTER BAR
34	P7948034	SLIDE BAR BOLT M10-1.5 X 35
35	P7948035	HEX BOLT M8-1.25 X 30
36	P7948036	FLAT WASHER M8
37	P7948037	HEX NUT M8-1.25
38	P7948038	HEX NUT M10-1.5
39	P7948039	SET SCREW M10-1.5 X 30
41	P7948041	HEX NUT M16-1.5 THIN
42	P7948042	SPRING CAP
43	P7948043	TORSION SPRING
44	P7948044	SPRING COVER
45	P7948045	PHLP HD SCR M5-.8 X 14
46	P7948046	LIGHT SWITCH
47	P7948047	GRIZZLY SAFETY PADDLE SWITCH
47C	P7948047C	SWITCH PLATE
47D	P7948047D	TAP SCREW M4 X 12

REF	PART #	DESCRIPTION
47E	P7948047E	YELLOW SWITCH KEY
48	P7948048	PHLP HD SCR M5-.8 X 10
49	P7948049	CORD CLAMP
50	P7948050	HEAD CASTING
51	P7948051	HEX BOLT M8-1.25 X 16
52	P7948052	SHIFTER
53	P7948053	LEFT SLIDE BAR
54	P7948054	RIGHT SLIDE BAR
55	P7948055	MOTOR BASE
56	P7948056	FLAT WASHER 12MM
57	P7948057	HEX NUT M12-1.75
58	P7948058	MOTOR 1-1/2HP 120/240V 1PH
58-1	P7948058-1	MOTOR FAN
58-2	P7948058-2	CAPACITOR COVER
58-3	P7948058-3	S CAPACITOR 400M 250V
58-4	P7948058-4	MOTOR JUNCTION BOX
58-5	P7948058-5	MOTOR FAN COVER
58-6	P7948058-6	CAST IRON END BELL FOR MOTOR
59	P7948059	MOTOR PULLEY
60	P7948060	KEY 5 X 5 X 25
61	P7948061	SET SCREW M6-1 X 10
62	P7948062	V-BELT A-27 4L290
63	P7948063	CENTER SHAFT
65	P7948065	BALL BEARING 6202ZZ
66	P7948066	EXT RETAINING RING 15MM
67	P7948067	CENTER PULLEY
68	P7948068	FLAT WASHER 8MM
69	P7948069	PHLP HD SCR M8-1.25 X 12
70	P7948070	PHLP HD SCR M5-.8 X 10
71	P7948071	FLAT WASHER 5MM
72	P7948072	PULLEY COVER KNOB
73	P7948073	PULLEY HOUSING 8-3/4 X 30-1/4"
74	P7948074	V-BELT A-33
75	P7948075	PULLEY NUT
76V2	P7947076V2	SPINDLE PULLEY V2.02.99
77V2	P7947077V2	INSERT PULLEY V2.02.99
78	P7948078	INT RETAINING RING 72MM
79	P7948079	BALL BEARING 6207ZZ
80	P7948080	SPACER
81	P7948081	BALL BEARING 6207ZZ
82	P7948082	EXT RETAINING RING 35MM
83	P7948083	SPANNER NUT
84	P7948084	TAB WASHER
85	P7948085	BALL BEARING 6206ZZ
86	P7948086	RUBBER WASHER
87	P7948087	QUILL
88	P7948088	BALL BEARING 6207ZZ
89	P7948089	SPINDLE
90A	P7948090A	ARBOR MT4/JT3
91	P7948091	DRILL CHUCK JT3 X 3/64-5/8"



G7948 Parts List (Cont.)

REF	PART #	DESCRIPTION
92	P7948092	CHUCK KEY
93	P7948093	SWITCH BOX
95A	P7947095A	LIGHT SOCKET ASSY.
97	P7948097	HEX WRENCH 3MM
98	P7948098	HEX WRENCH 4MM
99	P7948099	DRIFT KEY
100B	P7948100B	WIRE GASKET
100C	P7948100C	MOTOR CORD
100V3	P7948100V3	POWER CORD 14G 3W 72" 5-20P V3.01.21
102	P7948102	SLEEVE MT#4/#3
105	P7948105	SPEED CHART
107	P7948107	GRIZZLY BLACK/AL LABEL
110	P7948110	STRAIN RELIEF
111	P7948111	INT RETAINING RING 35MM
112	P79480112	DEGREE SCALE
113	P79480113	INDICATOR
114	P79480114	SET SCREW M10-1.5 X 28
115	P79480115	HEX NUT M10-1.5
116	P79480116	LOCK WASHER 3/4
117	P7948117	HEX NUT M12-1.5
118	P7948118	PHLP HD SCR M5-.8 X 10
119	P7948119	FLAT WASHER 5MM

REF	PART #	DESCRIPTION
120	P7948120	DEPTH STOP BRACKET
121	P7948121	DEPTH STOP SCALE STUD
122	P7948122	HEX NUT M8-1.25
123	P7948123	QUILL CLAMP
124	P7948124	CAP SCREW M8-1.25 X 20
125	P7948125	FLAT LOCK WRENCH 12/30MM
126	P7948126	CHUCK GUARD ASSEMBLY
126-1	P7948126-1	PHLP HD SCR M4-.7 X 30
126-2	P7948126-2	HEX NUT M4-.7
126-3	P7948126-3	TAP SCREW M2.2 X 4.5
126-4	P7948126-4	HEX BOLT M5-.8 X 12
126-5	P7948126-5	WING NUT M5-.8
127	P7948127	TERMINAL BAR
128	P7948128	METAL COVER
129	P7948129	PHLP HD SCR M4-.7 X 10
131	P7948131	HEX NUT M4-.7
132	P7948132	FLAT WASHER 4MM
133	P7948133	PHLP HD SCR M4-.7 X 20
135	P7948135	SUPPORT PLATE
136	P7948136	THRUST BEARING 51107
137	P7948137	HEX WRENCH 5MM



G7947/48 Labels & Cosmetics

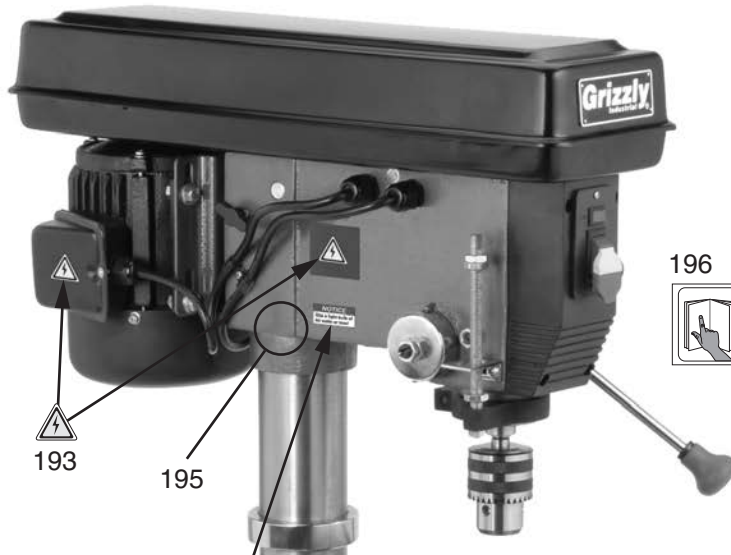

196



193

195

194

NOTICE
Use a light bulb of 60 watts or less!

191



103V2

Grizzly Industrial		MODEL G7947 12-SPEED FLOOR DRILL PRESS	
Specifications		WARNING!	
Motor: 1-1/2 HP, 120V/240V, 1-Ph, 60 Hz Full Load: 15.8A at 120V, 7.9A at 240V Spindle to Column Distance: 8-1/2" Max Spindle to Table Distance: 29" Spindle to Base Distance: 50-1/4" Number of Spindle Speeds: 12 Floor to Table Height: 24"-45-1/2" Spindle Speeds: 180-3240 RPM Spindle Travel: 4-3/4" Spindle Taper: MT#3 Weight: 245 lbs.		To reduce the risk of serious injury when using this machine: 1. Read and understand owner's manual before operating. 2. Always wear approved safety glasses. 3. Only plug power cord into a grounded outlet. 4. Disconnect power before setting up or servicing. 5. Avoid entanglement with spindle—tie back long hair, roll up long sleeves, and DO NOT wear loose clothing, gloves, or jewelry. 6. Properly set up machine before starting. 7. Keep all guards and covers in place during operation. 8. Clamp workpiece to table to prevent rotation. 9. Avoid positioning hands where they could slip into rotating bits. 10. Always remove chuck keys and other tools before starting. 11. Never attempt to slow or stop spindle with hands or tools. 12. Use correct speeds for drilling accessories and workpiece. 13. Do not operate when tired or under influence of drugs or alcohol. 14. Do not expose to rain or use in wet locations. 15. Prevent unauthorized use by children or untrained users; restrict access or disable machine when unattended.	
Date: _____ S/N: _____ Mfd. for Grizzly in China		MANUAL 	



193

REF	PART #	DESCRIPTION
103V2	P7947103V2	MACHINE ID LABEL CSA V2.09.17 (G7947)
103V2	P7948103V2	MACHINE ID LABEL CSA V2.09.17 (G7948)
191	P7947191	SHOCK-PINCH LABEL
193	P7947193	ELECTRICITY WARNING LABEL

REF	PART #	DESCRIPTION
194	P7947194	60W LIGHT BULB NOTICE
195	P7947195	TOUCH-UP PAINT, GRIZZLY GREEN
196	P7947196	READ-ENTANGLE-EYE LABEL

⚠ WARNING

Safety labels help reduce the risk of serious injury caused by machine hazards. If any label comes off or becomes unreadable, the owner of this machine **MUST** replace it in the original location before resuming operations. For replacements, contact (800) 523-4777 or www.grizzly.com.



WARRANTY & RETURNS

Grizzly Industrial, Inc. warrants every product it sells for a period of **1 year** to the original purchaser from the date of purchase. This warranty does not apply to defects due directly or indirectly to misuse, abuse, negligence, accidents, repairs or alterations or lack of maintenance. This is Grizzly's sole written warranty and any and all warranties that may be implied by law, including any merchantability or fitness, for any particular purpose, are hereby limited to the duration of this written warranty. We do not warrant or represent that the merchandise complies with the provisions of any law or acts unless the manufacturer so warrants. In no event shall Grizzly's liability under this warranty exceed the purchase price paid for the product and any legal actions brought against Grizzly shall be tried in the State of Washington, County of Whatcom.

We shall in no event be liable for death, injuries to persons or property or for incidental, contingent, special, or consequential damages arising from the use of our products.

The manufacturers reserve the right to change specifications at any time because they constantly strive to achieve better quality equipment. We make every effort to ensure that our products meet high quality and durability standards and we hope you never need to use this warranty.

In the event you need to use this warranty, contact us by mail or phone and give us all the details. We will then issue you a "Return Number," which must be clearly posted on the outside as well as the inside of the carton. We will not accept any item back without this number. Proof of purchase must accompany the merchandise.

Please feel free to write or call us if you have any questions about the machine or the manual.

Thank you again for your business and continued support. We hope to serve you again soon.

To take advantage of this warranty, you must register it at <https://www.grizzly.com/forms/warranty>, or you can scan the QR code below to be automatically directed to our warranty registration page. Enter all applicable information for the product.



grizzly.com[®]

TOOL WEBSITE

Buy Direct and Save with Grizzly[®] – Trusted, Proven and a Great Value!
~Since 1983~

*Visit Our Website Today For
Current Specials!*

**ORDER
24 HOURS A DAY!
1-800-523-4777**

