

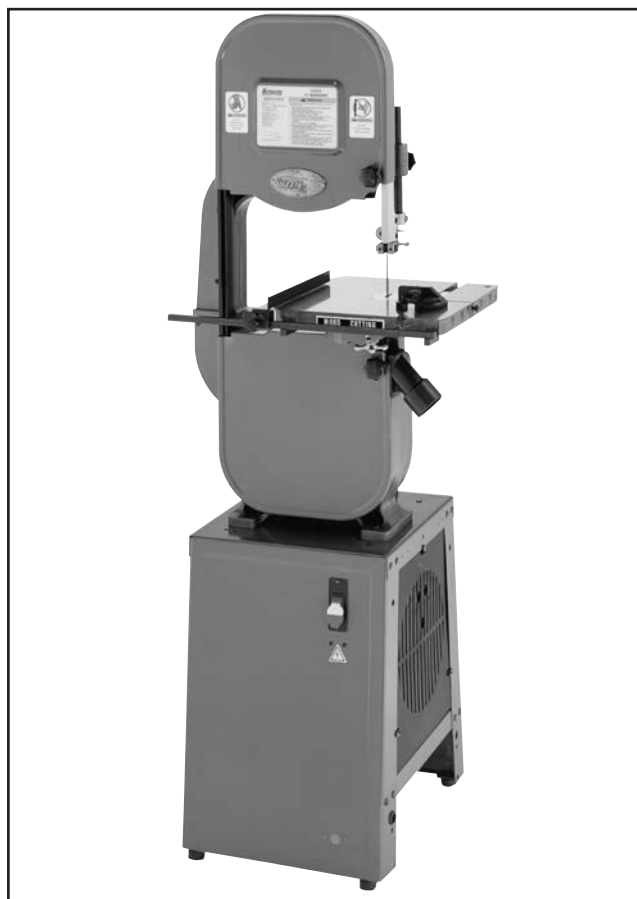

14" BANDSAW

MODEL G1019

INSTRUCTION MANUAL



COPYRIGHT © 1991 BY GRIZZLY INDUSTRIAL, INC.. REG.# TX 3 360 514
WARNING: NO PORTION OF THIS MANUAL MAY BE REPRODUCED IN ANY SHAPE
OR FORM WITHOUT THE WRITTEN APPROVAL OF GRIZZLY INDUSTRIAL, INC.
REVISED JULY, 2001. PRINTED IN TAIWAN

WARNING

Some dust created by power sanding, sawing, grinding, drilling, and other construction activities contains chemicals known to the State of California to cause cancer, birth defects or other reproductive harm. Some examples of these chemicals are:

- Lead from lead-based paints.
- Crystalline silica from bricks, cement, and other masonry products.
- Arsenic and chromium from chemically treated lumber.

Your risk from these exposures varies, depending on how often you do this type of work. To reduce your exposure to these chemicals: work in a well ventilated area, and work with approved safety equipment, such as those dust masks that are specially designed to filter out microscopic particles.

Table Of Contents

	PAGE
1. SAFETY	
SAFETY RULES FOR ALL TOOLS	2-3
ADDITIONAL SAFETY INSTRUCTIONS FOR BANDSAWS	4
2. CIRCUIT REQUIREMENTS	5
110V OPERATION	5
220V OPERATION	5
EXTENSION CORDS	6
GROUNDING.....	6
3. GENERAL INFORMATION	7
UNPACKING.....	8
PIECE INVENTORY	8
CLEAN UP	9
SITE CONSIDERATIONS	9
4. ASSEMBLY	10
STAND.....	10-12
SWITCH.....	13
BANDSAW TO STAND	14
V-BELT	14
STAND GUARDS	15
TABLE.....	16
DUST PORT	17
FENCE.....	17-18
BLADES.....	18
5. ADJUSTMENTS	19
LOCATION OF CONTROLS	19-20
BLADE TENSION	20
BLADE TRACKING	21
BLADE GUIDES	21-22
TABLE ADJUSTMENTS.....	22-24
FENCE ADJUSTMENTS	24
BLADE LEAD.....	25
TEST RUN.....	25
6. OPERATIONS	26
BLADE INFORMATION.....	27
CHANGING BLADES	27-28
RIPPING	28
STACKED CUTS.....	29
CUTTING CURVES.....	29
CIRCLE CUTTING ATTACHMENT	30
RESAWING	31
7. MAINTENANCE	32
GENERAL.....	32
TABLE.....	32
BEARINGS	32
V-BELT	32
8. CLOSURE	33
WIRING DIAGRAM.....	34
MACHINE DATA.....	35
TROUBLESHOOTING.....	36
PART BREAKDOWN.....	37-39
PART LISTS	40-41
WARRANTY AND RETURNS	42

SECTION 1: SAFETY

WARNING

For Your Own Safety Read Instruction Manual Before Operating This Equipment

The purpose of safety symbols is to attract your attention to possible hazardous conditions. This manual uses a series of symbols and signal words which are intended to convey the level of importance of the safety messages. The progression of symbols is described below. Remember that safety messages by themselves do not eliminate danger and are not a substitute for proper accident prevention measures.



Indicates an imminently hazardous situation which, if not avoided, WILL result in death or serious injury.



Indicates a potentially hazardous situation which, if not avoided, COULD result in death or serious injury.



Indicates a potentially hazardous situation which, if not avoided, MAY result in minor or moderate injury. It may also be used to alert against unsafe practices.

NOTICE

This symbol is used to alert the user to useful information about proper operation of the equipment.

WARNING

Safety Instructions For Power Tools

- KEEP GUARDS IN PLACE** and in working order.
- REMOVE ADJUSTING KEYS AND WRENCHES.** Form habit of checking to see that keys and adjusting wrenches are removed from tool before turning on.
- KEEP WORK AREA CLEAN.** Cluttered areas and benches invite accidents.
- NEVER USE IN DANGEROUS ENVIRONMENT.** Don't use power tools in damp or wet locations, or where any flammable or noxious fumes may exist. Keep work area well lighted.
- KEEP CHILDREN AND VISITORS AWAY.** All children and visitors should be kept a safe distance from work area.
- MAKE WORKSHOP CHILD PROOF** with padlocks, master switches, or by removing starter keys.
- NEVER FORCE TOOL.** It will do the job better and safer at the rate for which it was designed.
- USE RIGHT TOOL.** Don't force tool or attachment to do a job for which it was not designed.

WARNING

Safety Instructions For Power Tools

- 9. USE PROPER EXTENSION CORD.** Make sure your extension cord is in good condition. Conductor size should be in accordance with the chart below. The amperage rating should be listed on the motor or tool nameplate. An undersized cord will cause a drop in line voltage resulting in loss of power and overheating. Your extension cord must also contain a ground wire and plug pin. Always repair or replace extension cords if they become damaged.

Minimum Gauge for Extension Cords

AMP RATING	LENGTH		
	25ft	50ft	100ft
0-6	18	16	16
7-10	18	16	14
11-12	16	16	14
13-16	14	12	12
17-20	12	12	10
21-30	10	10	No

- 10. WEAR PROPER APPAREL.** Do not wear loose clothing, gloves, neckties, rings, bracelets, or other jewelry which may get caught in moving parts. Non-slip footwear is recommended. Wear protective hair covering to contain long hair.
- 11. ALWAYS USE SAFETY GLASSES.** Also use face or dust mask if cutting operation is dusty. Everyday eyeglasses only have impact resistant lenses, they are NOT safety glasses.
- 12. SECURE WORK.** Use clamps or a vise to hold work when practical. It's safer than using your hand and frees both hands to operate tool.
- 13. NEVER OVERREACH.** Keep proper footing and balance at all times.
- 14. MAINTAIN TOOLS WITH CARE.** Keep tools sharp and clean for best and safest performance. Follow instructions for lubricating and changing accessories.
- 15. DISCONNECT TOOLS** before servicing and changing accessories, such as blades, bits, cutters, and the like.
- 16. REDUCE THE RISK OF UNINTENTIONAL STARTING.** Make sure switch is in off position before plugging in.
- 17. USE RECOMMENDED ACCESSORIES.** Consult the owner's manual for recommended accessories. The use of improper accessories may cause risk of injury.
- 18. CHECK DAMAGED PARTS.** Before further use of the tool, a guard or other part that is damaged should be carefully checked to determine that it will operate properly and perform its intended function. Check for alignment of moving parts, binding of moving parts, breakage of parts, mounting, and any other conditions that may affect its operation. A guard or other part that is damaged should be properly repaired or replaced.
- 19. NEVER LEAVE TOOL RUNNING UNATTENDED. TURN POWER OFF.** Don't leave tool until it comes to a complete stop.
- 20. DO NOT OPERATE WHILE UNDER THE INFLUENCE** of drugs or alcohol, or while

WARNING

Additional Safety Instructions For Bandsaws

- 1. DO NOT OPERATE WITH DULL OR BADLY WORN BLADES.** Dull blades require more effort to use and are difficult to control. Inspect blades before each use.
- 2. NEVER POSITION FINGERS OR THUMBS IN LINE WITH THE CUT.** Serious personal injury could occur.
- 3. DO NOT OPERATE THIS BANDSAW WITHOUT WHEEL, PULLEY, AND BLADE GUARDS IN PLACE.**
- 4. WHEN REPLACING BLADES,** make sure teeth face down toward the table. The force of the cut is always down. Make sure the blade is properly tensioned.
- 5. CUTS SHOULD ALWAYS BE FULLY SUPPORTED** by the table or some type of support fixture. Always support round stock in a V-block.
- 6. DO NOT BACK WORKPIECE AWAY** from the blade while the saw is running. Plan your cuts so you always cut out of the wood. If you need to back the work out, turn the bandsaw off and wait for the blade to come to a complete stop. Do not twist or put excessive stress on the blade while backing work away.
- 8. ALWAYS FEED STOCK EVENLY AND SMOOTHLY.** Do not force or twist blade while cutting, especially when sawing small radii.
- 9. THIS MACHINE IS NOT DESIGNED TO CUT METAL** or other material except wood.
- 10. DO NOT MANUALLY STOP OR SLOW BLADE** after turning off the saw. Allow it to come to a complete stop before you leave it unattended.
- 11. ALL INSPECTIONS, ADJUSTMENTS, AND MAINTENANCE ARE TO BE DONE WITH THE POWER OFF** and the plug pulled from the outlet. Wait for all moving parts to come to a complete stop.
- 12. HABITS – GOOD AND BAD – ARE HARD TO BREAK.** Develop good habits in your shop and safety will become second-nature to you.
- 13. IF AT ANY TIME YOU ARE EXPERIENCING DIFFICULTIES PERFORMING THE INTENDED OPERATION, STOP USING THE MACHINE!** Then contact our service department or ask a qualified expert how the operation should be performed.

WARNING

Like all power tools, there is danger associated with bandsaws. Accidents are frequently caused by lack of familiarity or failure to pay attention. Use this tool with respect and caution to lessen the possibility of operator injury. If normal safety precautions are overlooked or ignored, serious personal injury may occur.

CAUTION

No list of safety guidelines can be complete. Every shop environment is different. Always consider safety first, as it applies to your individual working conditions. Use this and other machinery with caution and respect. Failure to do so could result in serious personal injury, damage to equipment or poor work results.

SECTION 2: CIRCUIT REQUIREMENTS

110V Operation

The motor supplied with the Model G1019 is a dual-voltage 110V or 220V motor prewired for 110V. Under 110V use, the motor draws approximately 12 amps. We recommend a 15 amp circuit breaker for 110V. This should be satisfactory for normal use, while providing enough protection against circuit damage caused by power surges. Grizzly recommends that the circuit you use should be dedicated, (i.e., the Model G1019 should provide the only draw from that circuit). If frequent circuit failures occur when using the bandsaw, contact our service department or your local electrical contractor.

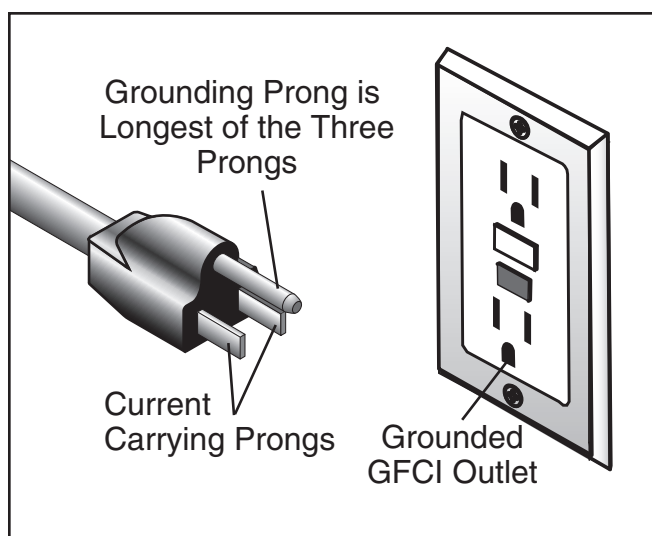

Figure 1. Typical 110V 3-prong plug and outlet.



220V Operation

The motor supplied with the Model G1019 can be rewired to operate at 220V. See enclosed wiring diagram for details.

If converting to operate at 220V, a suitable 220V plug must be wired in. When operating at 220V, we recommend using a NEMA-style 6L-15 plug and outlet. **See Figure 2.** You may also “hard-wire” the machine directly to your panel, provided you place a disconnect switch near the machine. Check the electrical codes in your area for specifics on wiring requirements.

Under normal use, the motor draws approximately 6 amps at 220V. We recommend a 15 amp circuit breaker. This should be satisfactory for normal use while providing enough protection against circuit damage caused by power surges.

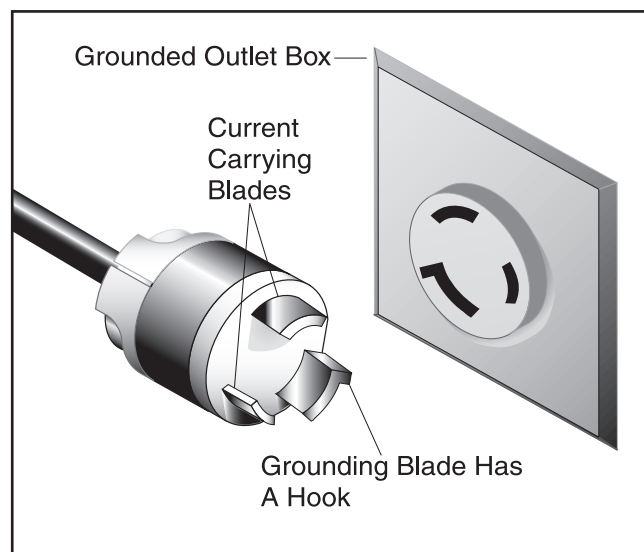

Figure 2. Recommended 220V receptacle.



Extension Cords

Should it be necessary to use an extension cord, make sure the cord is rated Hard Service (grade S) or better. Refer to the chart on page 3 to determine the minimum gauge for the extension cord. The extension cord must also contain a ground wire and plug pin. Always repair or replace extension cords when they become worn or damaged.

We do not recommend the use of extension cords on 220V equipment. It is much better to arrange the placement of your equipment and the installed wiring to eliminate the need for extension cords.

CAUTION

We have covered some basic electrical requirements for the safe operation of your Bandsaw. These requirements are not necessarily comprehensive. You must be sure that your particular electrical configuration complies with local and state codes. Ensure compliance by checking with your local municipality or a licensed electrician.



Grounding

In the event of an electrical short, grounding provides electric current a path of least resistance to reduce the risk of electric shock. This tool is equipped with an electric cord having an equipment-grounding conductor. The plug must be plugged into a matching outlet that is properly installed and grounded in accordance with all local codes and ordinances.

Improper connections of the electrical-grounding conductor can result in risk of electric shock. The conductor with green or green and yellow striped insulation is the electrical grounding conductor. If repair or replacement of the electric cord or plug is necessary, do not connect the equipment grounding conductor to a live terminal.

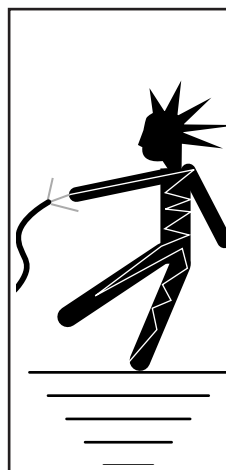

WARNING

This equipment must be grounded. Verify that any existing electrical outlet and circuit you intend to plug into is actually grounded. Under no circumstances should the grounding pin from any three-pronged plug be removed. Serious injury may occur.



SECTION 3: GENERAL INFORMATION

Commentary

Grizzly Industrial, Inc. is proud to offer the Model G1019 14" Bandsaw. The Model G1019 is part of Grizzly's growing family of fine woodworking and metalworking machinery. When used according to the guidelines stated in this manual, you can expect years of trouble-free, enjoyable operation.

The Model G1019 features cast iron construction for rigidity and strength, a solid cast iron table, a steel stand, fence and miter gauge and a $\frac{3}{8}$ " blade. The electrical package consists of a 3450 R.P.M., $\frac{3}{4}$ H.P. capacitor start motor, locking toggle switch and cord set. Also included is a circle cutting guide to produce circular cuts up to 12" in diameter. Many accessories are also available for the Model G1019. Consult the current Grizzly catalog for prices and ordering information.

All running parts utilize shielded ball bearings that require no lubrication.

We are also pleased to provide this manual with the Model G1019. It was written to guide you through assembly, review safety considerations, and cover general operating procedures. It represents our effort to produce the best documentation possible. If you have any comments regarding this manual, please write to us at the address below:

Grizzly Industrial, Inc.
% Technical Documentation
P.O. Box 2069
Bellingham, WA 98227-2069

Above all else, we stand behind our machines. We have an excellent service department at your disposal should the need arise. If you have any service questions or parts requests, please call or write to us at the location listed below.

Grizzly Industrial, Inc.
2406 Reach Road
Williamsport, PA 17701
Phone: (570) 546-9663
Fax: (800) 438-5901
E-Mail: techsupport@grizzly.com
Web Site: www.grizzly.com

Address after fall 2001:

Grizzly Industrial, Inc.
1203 Lycoming Circle
Pennsdale, PA 17756

The specifications, drawings, and photographs illustrated in this manual represent the Model G1019 as supplied when the manual was prepared. However, owing to Grizzly's policy of continuous improvement, changes may be made at any time with no obligation on the part of Grizzly. Whenever possible, though, we send manual updates to all owners of a particular tool or machine. Should you receive one, we urge you to insert the new information with the old and keep it for reference.

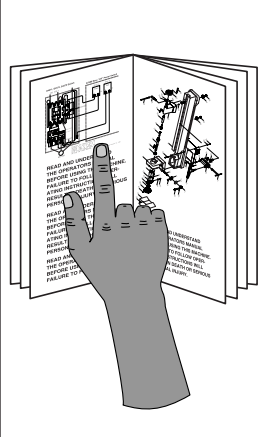
	<p>!WARNING</p> <p>Read the manual before assembly and operation. Become familiar with the machine and its operation before beginning any work. Serious personal injury may result if safety or operational information is not understood or followed.</p>
--	--



Unpacking

The Model G1019 Bandsaw is shipped from the manufacturer in a carefully packed carton. If you discover the machine is damaged after you've signed for delivery, please call Customer Service immediately for advice.

Save the containers and all packing materials for possible inspection by the carrier or its agent. Otherwise, filing a freight claim can be difficult.

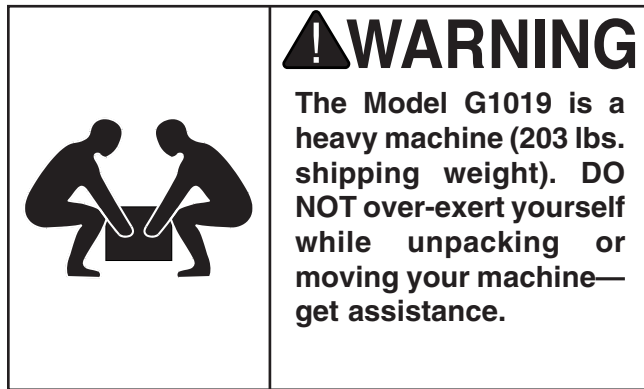

When you are completely satisfied with the condition of your shipment, you should inventory its parts.



Piece Inventory

After all the parts have been removed from the container, you should have:

- 11 Stand Components
- 1 Working Table Assembly
- 1 Trunnion Support Bracket
- 1 Motor
- 1 Miter Gauge
- 2 Hardware Bags
- 1 Bandsaw Unit
- 1 Pulley Cover
- 2 Fence Assemblies
- 1 Circle Cutting Attachment
- 1 V-Belt
- 1 6" Pulley

Contents of first Bolt bag:

- 1 $\frac{5}{16}$ "-18 x 3" Hex Bolt
- 1 $\frac{5}{16}$ "-18 Hex Nut
- 2 $\frac{1}{4}$ "-20 x $\frac{1}{2}$ " Cap Screws
- 1 5 x 5 x 23 mm Key
- 1 Knob
- 2 Table Lock Handles
- 1 Table Pin
- 1 2 $\frac{3}{4}$ " Motor Pulley

Contents of second Bolt bag:

- 20 $\frac{5}{16}$ "-18 x $\frac{1}{2}$ " Carriage Bolts
- 56 $\frac{5}{16}$ " Flat Washers
- 36 $\frac{5}{16}$ "-18 Hex Nuts
- 8 $\frac{5}{16}$ "-18 x $\frac{3}{4}$ " Hex Bolts
- 4 $\frac{5}{16}$ "-18 x 1 Hex Bolts
- 4 $\frac{5}{16}$ "-18 x 2" Hex Bolts
- 4 $\frac{1}{4}$ "-20 x $\frac{3}{4}$ " Phlp. Hd. Screws
- 4 $\frac{1}{4}$ "-20 Hex Nut
- 4 $\frac{1}{4}$ " Flat Washers
- 4 10-24 x $\frac{1}{2}$ " Phlp. Hd. Screws
- 4 #10 Lock Washers
- 4 #10 Wing Nuts

In the event that any nonproprietary parts are missing (e.g. a nut or a washer...), we would be glad to replace them, or, for the sake of expediency, replacements can be obtained at your local hardware store.



Clean up

The unpainted surfaces are coated with a waxy oil to protect them from corrosion during shipment. Remove this protective coating with a solvent cleaner or citrus-based degreaser such as Grizzly's G7895 Degreaser. Avoid chlorine-based solvents because they may damage painted surfaces should they come in contact. Always follow the usage instructions on the product you choose to clean.

	<p>⚠ WARNING Do not use gasoline or other petroleum-based solvents to clean with. They have low flash points which makes them extremely flammable. A risk of explosion and burning exists if these products are used. Serious personal injury may occur.</p>
---	---

	<p>⚠ WARNING Do not smoke while using solvents. A risk of explosion or fire exists and may result in serious personal injury.</p>
---	--

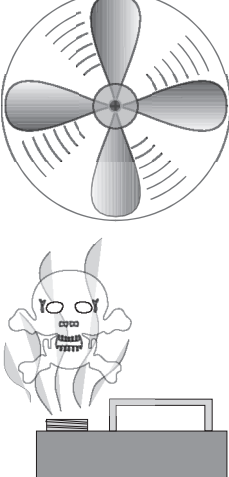
	<p>⚠ CAUTION Many of the solvents commonly used to clean machinery can be toxic when inhaled or ingested. Always work in well-ventilated areas far from potential ignition sources when dealing with solvents. Use care when disposing of waste rags and towels to be sure they do not create fire or environmental hazards.</p>
---	---



Site Considerations

FLOOR LOAD

Your Model G1019 Bandsaw represents a moderately large weight load in a small footprint. Most commercial or home shop floors should be sufficient to carry the weight of the Model G1019. If you question the strength of your floor, you can opt to reinforce it.

WORKING CLEARANCES

Working clearances can be thought of as the distances between machines and obstacles that allow safe operation of every machine without limitation. Consider existing and anticipated machine needs, size of material to be processed through each machine, and space for auxiliary stands and/or work tables. Also consider the relative position of each machine to one another for efficient material handling. Be sure to allow yourself sufficient room to safely run your machines in any foreseeable operation.

LIGHTING AND OUTLETS

Lighting should be bright enough to eliminate shadow and prevent eye strain. Electrical circuits should be dedicated or large enough to handle combined motor amp loads. Outlets should be located near each machine so power or extension cords are not obstructing high-traffic areas. Be sure to observe local electrical codes for proper installation of new lighting, outlets, or circuits.

	<p>⚠ CAUTION Make your shop "child safe." Ensure that your workplace is inaccessible to children by closing and locking all entrances when you are away. Never allow visitors in your shop when assembling, adjusting or operating equipment.</p>
--	--



SECTION 4: ASSEMBLY

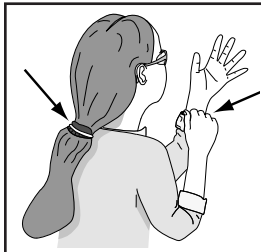

! WARNING

Keep clothing rolled up and out of the way of machinery and keep hair pulled back.

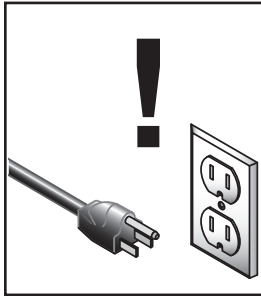

! WARNING

Disconnect power to the machine when performing any maintenance or assembly. Failure to do this may result in serious personal injury.



! WARNING

Wear safety glasses during the entire assembly process. Failure to comply may result in serious personal injury.



! CAUTION

Some metal parts may have sharp edges on them after they are formed. Please examine the edges of all metal parts before handling them. Failure to do so could result in injury.

Stand

The Model G1019 Bandsaw stand is an A-frame, panel-style stand. The front and rear panels are connected with one panel at the top and two cross braces near the bottom.

Sometimes sheet metal parts have a tendency to "spring" after they are formed. For this reason, you may need to use a little extra force to align holes to insert bolts.

1. Start with the stand panel with the switch mounted in it. Turn the panel upside down and attach the rubber feet using (2) $\frac{1}{4}$ "-20 x 1" Phillips® head screws, (2) flat washers and (2) hex nuts provided. Tighten down. **See Figure 3.** Repeat this step with the second stand panel.

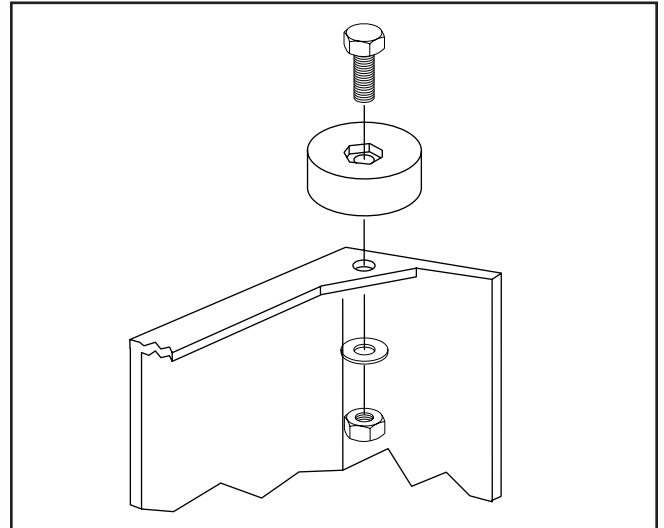

Figure 3. Attach rubber feet first.

- Stand the panels up so the rubber feet are on the floor. Attach two cross braces to one of the side panels using (4) $\frac{1}{4}$ "-20 x $\frac{1}{2}$ " carriage bolts, flat washers and hex nuts provided. Next, attach the other side panel to the cross braces already mounted. **See Figure 4.** Note: Do not tighten any fasteners at this time.

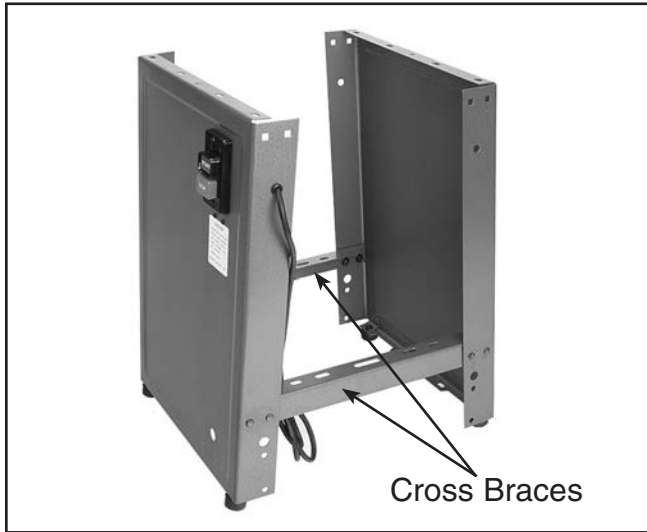

Figure 4. Attach cross braces.

- Now, turn the stand over and attach the motor support plate using (4) $\frac{5}{16}$ "-18 x $\frac{3}{4}$ " hex bolts, (8) washers and (4) hex nuts. **See Figure 5.**

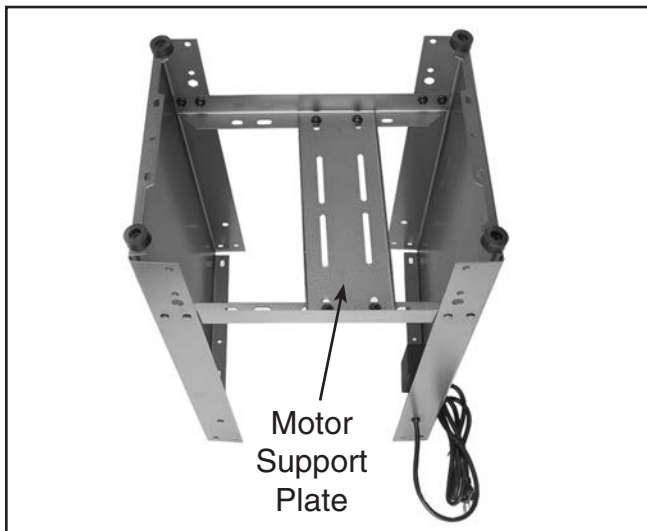

Figure 5. Install motor support plate.

- Turn the stand right side up and attach the motor mount plate to the motor mount support plate using (4) $\frac{5}{16}$ "-18 x $\frac{3}{4}$ " hex bolts, (8) flat washers and (4) hex nuts. **See Figure 6.**

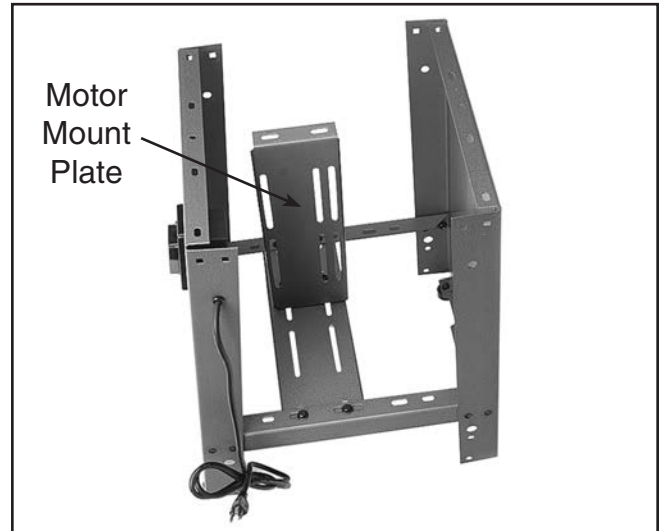

Figure 6. Add motor mount plate.

- Mount the double bend brace to the motor mount plate. Use (2) $\frac{5}{16}$ "-18 x $\frac{3}{4}$ " hex bolts, (8) flat washers and (2) hex nuts. **See Figure 7.**

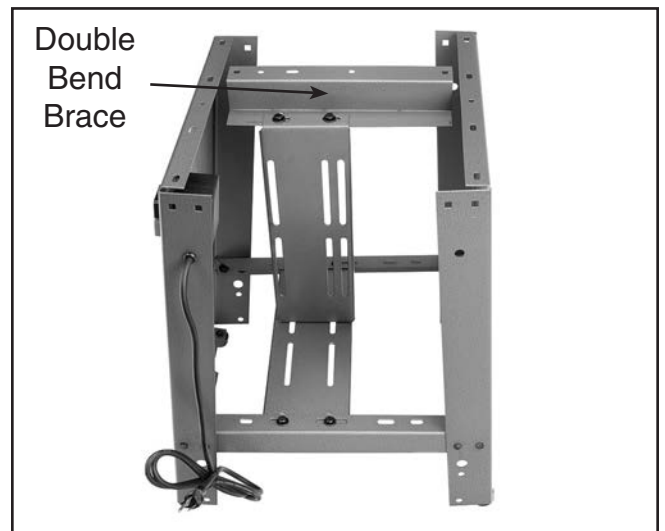

Figure 7. Mount double bend brace.

6. Attach the right angle brace to the bottom of the top panel using (2) $\frac{5}{16}$ "-18 x $\frac{1}{2}$ " carriage bolts, (2) flat washers and (2) hex nuts. Finger tighten only. **See Figure 8.**

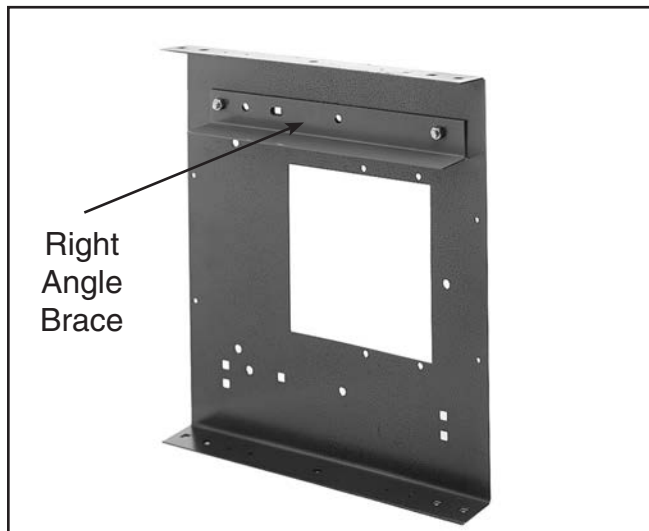

Figure 8. Attach right angle brace.

7. Install the top panel using (10) $\frac{5}{16}$ "-18 x $\frac{1}{2}$ " carriage bolts, (10) flat washers and (10) hex nuts. It may be necessary to wiggle the panels a bit to line up the bolt holes. Finger tighten only. **See Figure 9.**

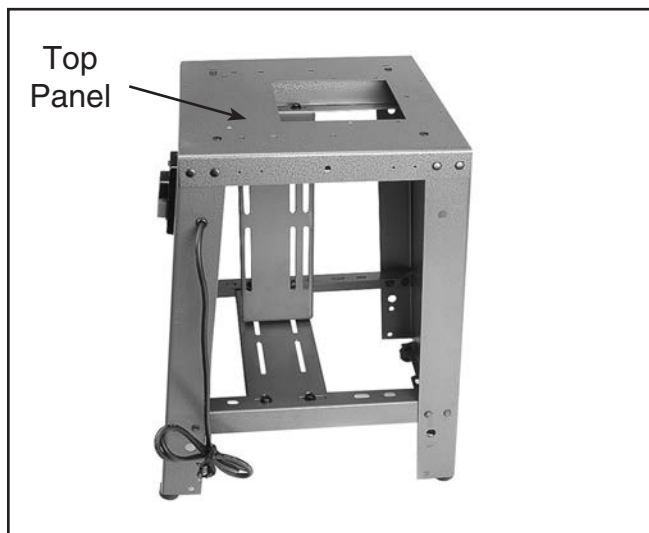

Figure 9. Install top panel.

8. Place the drive pulley on the motor shaft and line up the keyways. Insert the key and tighten down the pulley setscrew. **See Figure 10.**

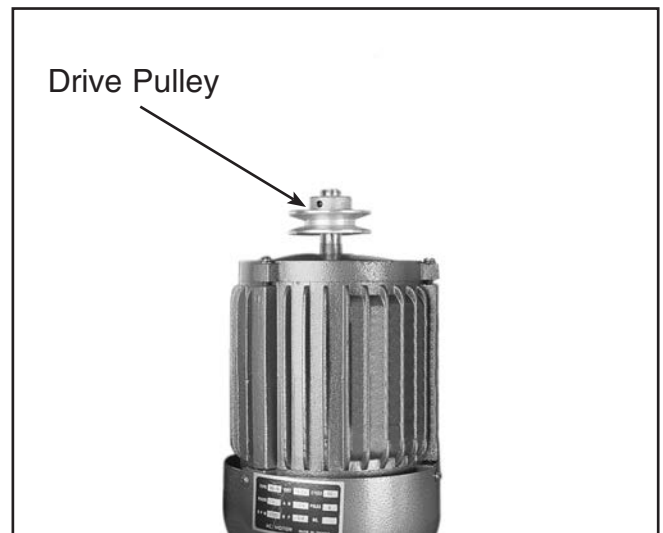

Figure 10. Drive pulley placed on shaft.

9. Lay the stand on its side. Carefully set the motor on the motor bracket (see **Figure 11**) and line up the holes. Secure the motor using (4) $\frac{5}{16}$ "-18 x 1" hex bolts, (4) hex nuts and (8) flat washers, finger tight only. Slide the motor to the top of the stand as far as it will go. Tighten the top two motor bolts down leaving the bottom two finger tight. Set the stand upright at this time.

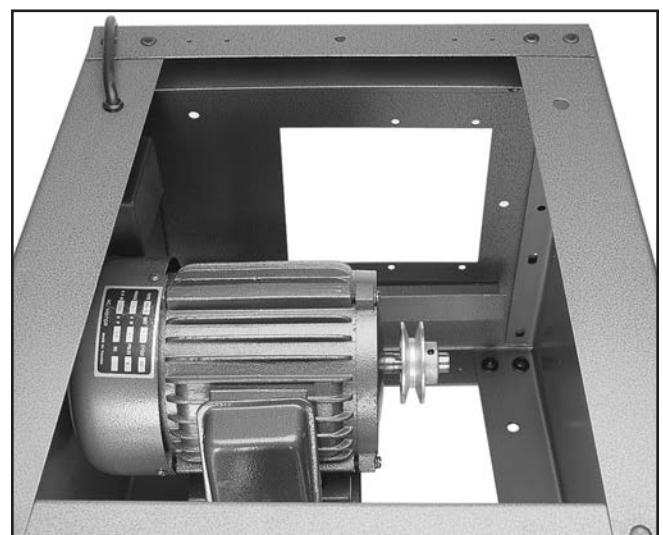

Figure 11. Place drive pulley.



Switch

The switch is pre-mounted on the bandsaw unit. To lock-out the switch, you must unplug the safety key from the top of the paddle as shown in **Figure 12**. Never substitute unplugging the machine from the power source with removing the lock-out key from the switch.



Figure 12. Removing lock-out key from switch.

To connect the switch power to the motor, plug the male end into the female end as shown in **Figure 13**.



Figure 13. Connecting switch to motor.



Bandsaw To Stand

1. Place the bandsaw unit on the stand and align the 4 holes in the base over the 4 mounting holes in the stand. Get help with this step as the bandsaw unit is very heavy and awkward for one person to handle.
2. Loosely secure the bandsaw base to the stand with the four (4) $\frac{5}{16}$ "-18 x $1\frac{1}{2}$ " hex bolts, nuts, and washers provided. **See Figure 14.**

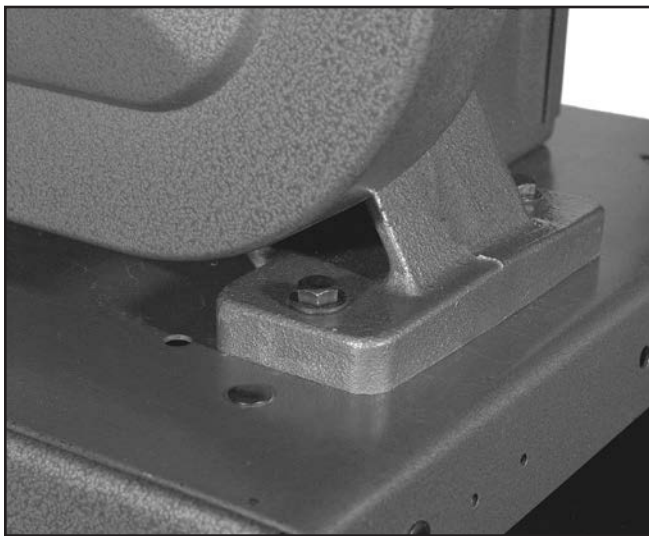

Figure 14. Loosely fasten to base.

3. The large drive pulley is installed from the factory.
4. Loosen the motor mount bolts. Lift the motor up high enough to slip the V-belt over both pulleys. Set the motor back down to the end of its travel. V-belt alignment and tensioning will be covered in the next section.
5. Move the bandsaw back and forth on the stand to ensure that the bandsaw stand is seated properly. Ensure that the stand is symmetrical when viewed from the front and the side. Tighten all fasteners except for the motor mount bolts.



V-Belt

1. The weight of the motor against the V-belt should offer adequate belt tension. Adjust the motor parallel to the axis of the upper drive shaft/pulley and tighten the motor mount bolts.
2. The upper and lower pulleys must be aligned with each other to prevent premature V-belt wear. Set a straight edge (or a plumb bob if saw is level) against the upper pulley. If the straightedge touches both pulleys evenly, the pulleys are aligned. If the straightedge does not touch both pulleys evenly, the pulleys are not aligned. **See Figure 15.**
3. Three options are available when aligning pulleys depending upon the amount and nature of the misalignment:
 - A. Loosen one or both of the pulley setscrews on their shafts and slide the pulleys in or out along their shafts.
 - B. Rock the motor clockwise or counter-clockwise in relation to the upper drive shaft/pulley.
 - C. Moving the lower portion of the motor mount bracket in or out.

Remember to retighten the setscrews and bolts when finished.

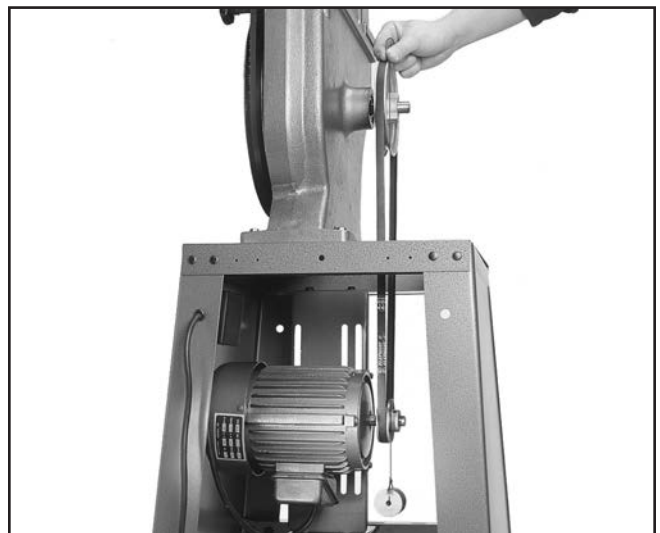

Figure 15. Aligning pulleys with plumb bob.



Stand Guards

1. Place the pulley and belt guard case over the drive pulley and secure using the #10-24 x 1/2" pan head screws, lock washers, flat washers and wing nuts supplied. **See Figure 16.**
2. Insert the black plastic stand panels/covers in place. **See Figure 17.**

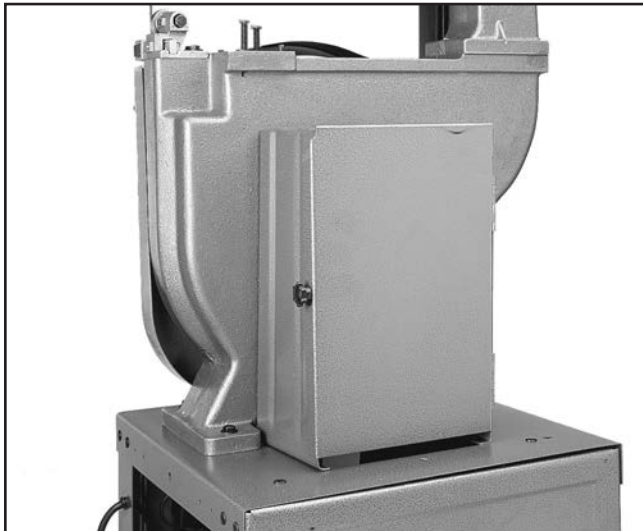

Figure 16. Guard case in place.



Figure 17. Panel cover insertion.

CAUTION

Never operate machine without the guard case and panel cover in Figures 16 and 17 in place. Ignoring this caution creates a potentially hazardous situation in which clothing, hair, hands or other body parts may be pulled into the moving belt(s), causing moderate to severe personal injury.



Table

To mount the bandsaw table:

1. Remove the two table support mounting bolts from the bandsaw unit.
2. Line up the pin location on the mounting bracket with the pin on the bandsaw unit. Insert the two mounting bolts and securely tighten. **See Figure 18.**

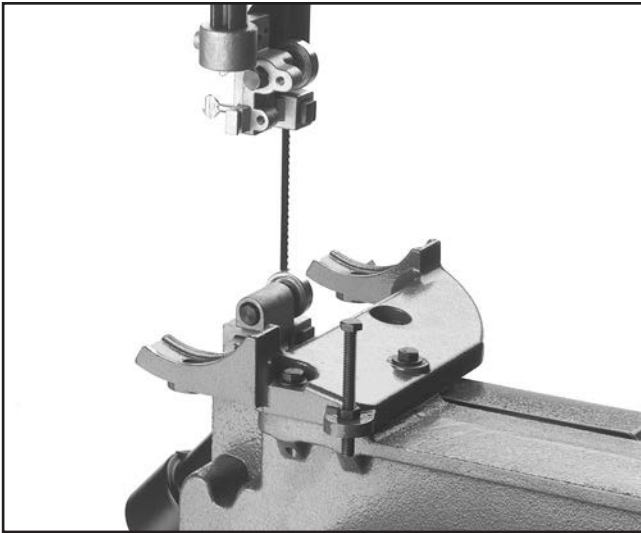

Figure 18. Table mounting bracket.

3. Insert the $\frac{5}{16}$ "-18 x 3" table indexing bolt with lock nut in the threaded hole in the support bracket.
4. Slip the table past the blade through the table slot and set the table trunnions onto the support bracket. Make sure the bolts drop through the support bracket.

5. Secure the table to the support bracket by tightening the two star knobs. **See Figure 19.** Remember to position the table so that the miter slot is to the right of the blade as you face the front of the bandsaw.

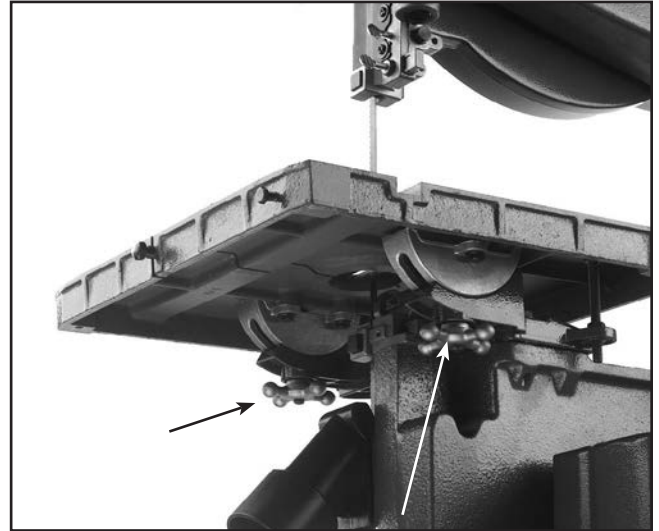

Figure 19. Star knobs

6. Place the table insert in the table top and slide the tapered pin so it fits snug in the hole on the side of the table.

NOTICE

The tapered table pin must be in position when operating the bandsaw.



Dust Port

The dust port mounts underneath the table on the lower wheel cover. To install the dust port:

1. Fit the dust port over the two holes on the lower wheel cover.
2. Use the two 1/4"-20 x 1/2" hex bolts and 1/4" washers to secure the dust port to the cover. **See Figure 20.**



Figure 20. Dust port in place.



Fence

To mount the fence to the bandsaw table:

1. Loosen the two mounting brackets secured to the square fence rail and swing the brackets so they are perpendicular to the fence rail.
2. Position the mounting brackets under the front of the bandsaw table and attach with the two socket head cap screws provided. **See Figure 21.**



Figure 21. Fence rail bracket attachment.

3. Square the assembly and tighten each cap screw.
4. Slip the fence onto the fence rail. To lock the fence in position, tighten the fence knob. **See Figure 22.**

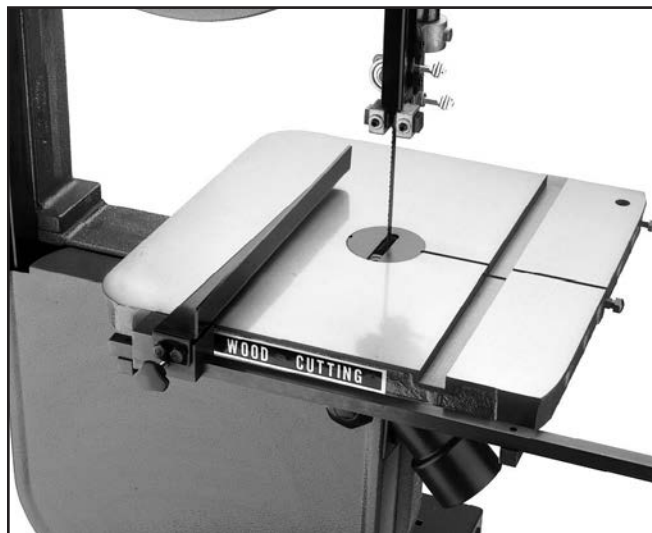

Figure 22. Fence in position.



Blades

A $\frac{3}{8}$ " blade is included with the bandsaw and is already installed on the machine. Refer to **Section 5: Adjustments** for detail on blade tensioning and blade tracking before starting the machine. Refer to **Section 6: Operations** for instructions on selecting and changing blades.

This concludes the assembly process. Please **DO NOT** operate this saw until you have reviewed the Safety Information and have read the **Adjustment** and **Operation** sections.

CAUTION

Do not operate this bandsaw until you have completed the adjustments noted in the next section and have reviewed all safety information. Serious personal injury may result.



SECTION 5: ADJUSTMENTS

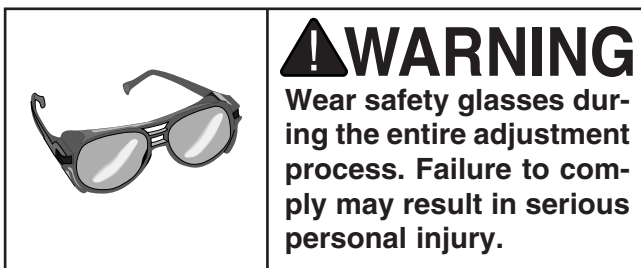
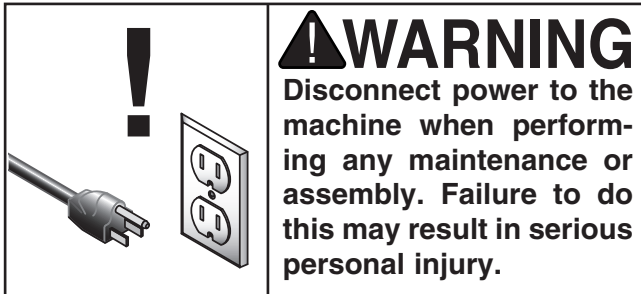

Location Of Controls

General control and adjustment locations are shown in **Figure 23** and are described below.

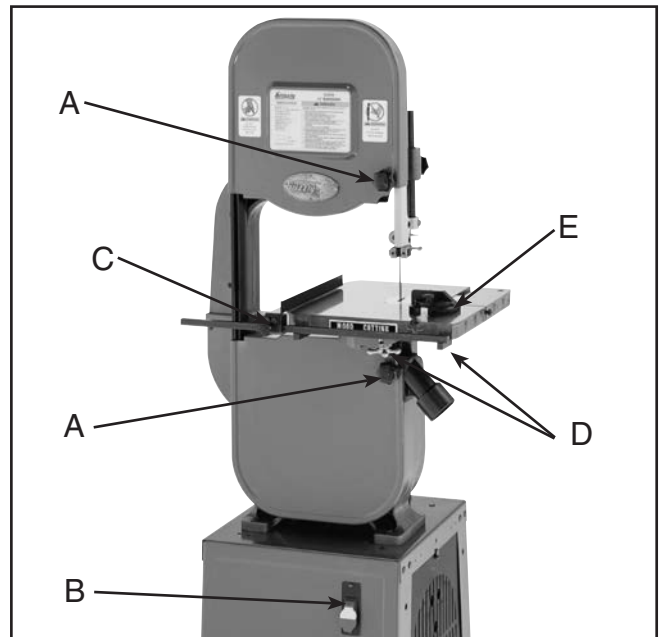

Figure 23. Location of controls.

- A.** These two knobs secure the upper and lower wheel covers. The covers are only opened to change a blade or make an adjustment to blade tracking.
- B.** This is the push button switch that controls the power to the motor.
- C.** This knob locks the rip fence in position.
- D.** These trunnion knobs are used to lock the table in position.
- E.** The miter gauge slides in the milled groove in the table and can be set at any angle between 45° left and 45° right. Use the miter gauge for crosscutting and miter-cutting.

Now, direct your attention to the controls located around the backside of the upper cover of the saw. **See Figure 24.**

- F.** This knob is used to control blade tension. Turning clockwise increases tension; counterclockwise decreases tension.
- G.** This knob controls blade tracking. Note that the knob has a locknut to lock tracking in place.
- H.** This handle locks the upper blade guide assembly in position. The upper guide should be adjusted to within $\frac{1}{4}$ " of the workpiece for optimum blade support. Do not operate bandsaw without locking the guide post handle.

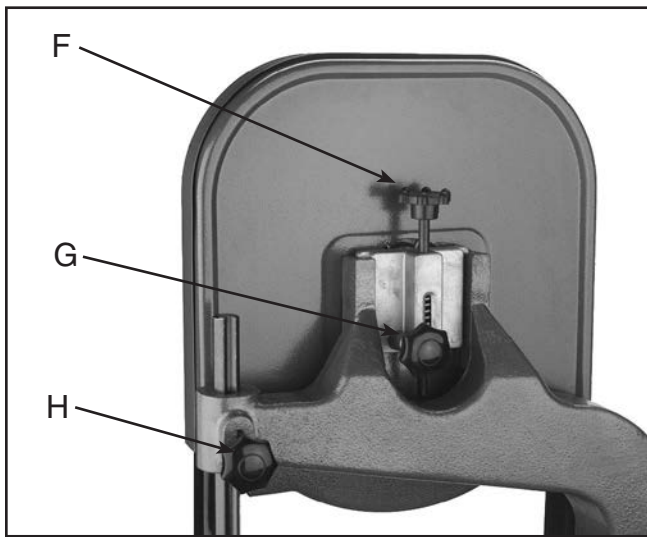

Figure 24. Location of blade controls.

! WARNING

Do not make adjustments while the bandsaw is running. Ensure that the switch is off, power is disconnected, and moving parts have stopped before making adjustments. Check adjustments while power is still disconnected by manually turning the bandsaw wheel by hand.



Blade Tension

Proper blade tension is important for optimum bandsaw performance. **See Figure 24** for bandsaw tension controls. To increase blade tension, turn the blade tension knob clockwise. To reduce blade tension, turn the blade tension knob counterclockwise.

Since a variety of blades will work well with this saw, final blade tension ultimately depends on the type and size of blade you use. Thinner blades require less tension than wide blades. Too much tension will result in blade breakage. A properly tensioned blade will track the cutting line accurately and the cut will be smoother.

Proper blade tension can best be achieved by determining the amount of blade deflection:

1. Ensure that the power is off and the saw is unplugged. Raise the upper guide assembly all the way and lock in place.
2. Press, with moderate pressure, on the face of the blade with your thumb.
3. Turn the tensioning knob to adjust the amount of tension. The blade should deflect about $\frac{1}{4}$ ".

If the tension seems correct, make all of the other adjustments to the saw and test run. If the blade is not cutting properly, the tension may be incorrect and readjustment may be needed.

Remember to reduce the blade tension when the bandsaw is not in use, this will help to prevent premature breakage of the blade and/or the rubber tires.



Blade Tracking

The blade should track so the body of the blade is centered on the upper wheel and tire. The rubber tire is slightly crowned in the middle which helps to keep the blade centered and avoids having the teeth of the blade come in contact with the tire material. **See Figure 24** for bandsaw tracking controls.

To adjust blade tracking:

1. Disconnect the bandsaw from the power source.
2. Adjust the upper and lower guide blocks and support bearings away from the blade.
3. Loosen the locknut on the tracking control knob and turn the knob clockwise or counter-clockwise while turning the upper wheel by hand. When turning the wheel by hand, ensure that you don't cut your hand on the teeth of the blade.
4. Turn the upper wheel and tracking knob until the blade is centered on the upper wheel and tire. Turn the wheel at least three more full turns to ensure that the blade will remain tracking in this position.
5. Retighten the locknut and double check blade tracking.
6. Install the upper wheel cover.

CAUTION

The bandsaw blade is dangerously sharp. Use extreme caution when working near the saw blade. Failure to exercise care could result in severe injury.



Blade Guides

Whenever changing a blade or adjusting tension and tracking, the upper and lower blade support bearings and guide blocks must be readjusted. Always adjust the assemblies away from the blade before installing a new blade or making blade tracking adjustments. After blade tension and tracking are set correctly, readjust the upper and lower support bearings and guide block assemblies into position. **See Figure 25** for upper blade guide location and **Figure 26** for lower blade guide location.

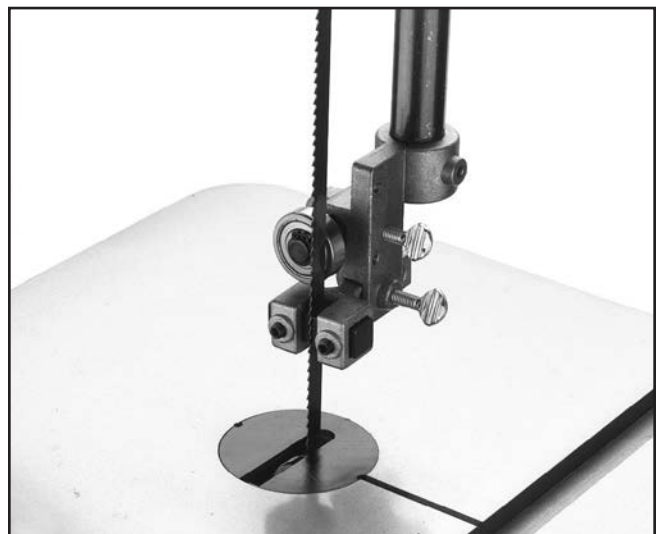

Figure 25. Upper blade guide assembly.



Figure 26. Lower blade guide assembly.

Support Bearings

The support bearings back-up the blade during the sawing operation. To adjust the support bearings, loosen the thumbscrews on the upper assembly or the setscrews on the lower assembly which secure the support bearing shafts. **See Figure 27.** Adjust the shafts in or out so that the upper and lower support bearings are within $\frac{1}{64}$ " of the back edge of the blade. Tighten the screws.

Guide Blocks

The guide blocks ensure that the blade stays aligned laterally. For optimum support, the guide block assemblies should be adjusted so they are just behind the gullet line (the hollow points) of the blade. To adjust the guide block assemblies, loosen the thumbscrews securing the guide block yoke assemblies and move in or out in relation to the blade gullets. Once adjusted, retighten the thumbscrews.

To adjust the guide blocks laterally, loosen the guide block lateral adjustment thumbscrews and adjust each block so it is about 0.004" from the blade. This is about the same thickness as a dollar bill. Retighten the thumbscrews and turn the upper wheel by hand through a complete revolution of the blade length to ensure that the blade weld passes through the guide blocks unhin-

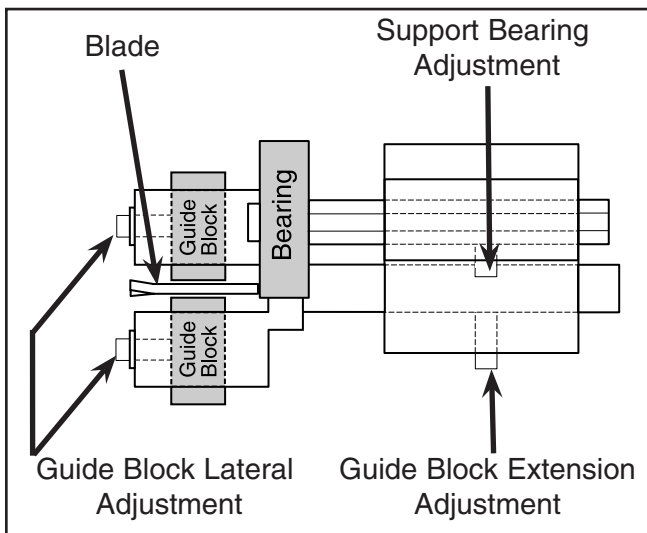

Figure 27. Blade guide adjustments.

Table Adjustments

The bandsaw table will tilt left 10° and right 45° from horizontal. When tilting the table to the right, the positive stop adjusting bolt automatically indexes the table back to perpendicular to the blade.

To tilt the table to the right:

1. Loosen the two trunnion knobs below the table trunnions. **See Figure 28** for location.
2. Position the table to the desired angle. Refer to the angle gauge on the front table support trunnion.
3. Tighten the trunnion knobs.

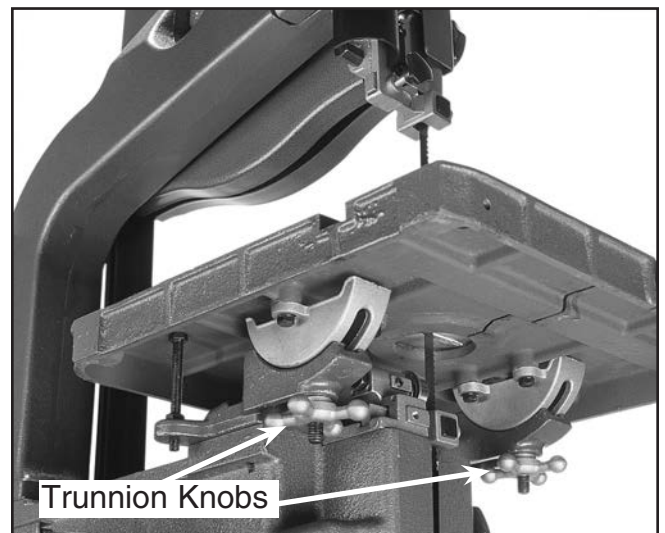

Figure 28. Table tilt trunnion knobs.



To tilt the table to the left:

1. Loosen the two trunnion knobs below the table trunnions.
2. Tilt the table to the right enough to gain clearance to the positive stop bolt. Loosen the lock nut, then remove the positive stop bolt.
3. The table will now tilt left to approximately 10°.
4. When the left tilt operation is complete, reinstall the positive stop bolt.

To adjust the positive stop so the table will be perpendicular (90°) to the blade:

1. Loosen two trunnion knobs and the locknut securing the positive stop adjusting bolt.
2. Raise the upper blade guide assembly and place a 6" adjustable square or try-square on the table against the blade. **See Figure 29.** Adjust the positive stop adjusting bolt so that the table is positioned at a 90° angle to the blade.
3. Secure the trunnion knobs and lock the positive adjusting bolt by tightening the locknut. Ensure that the bolt does not turn while tightening the locknut. Set the angle pointer to zero for future reference.

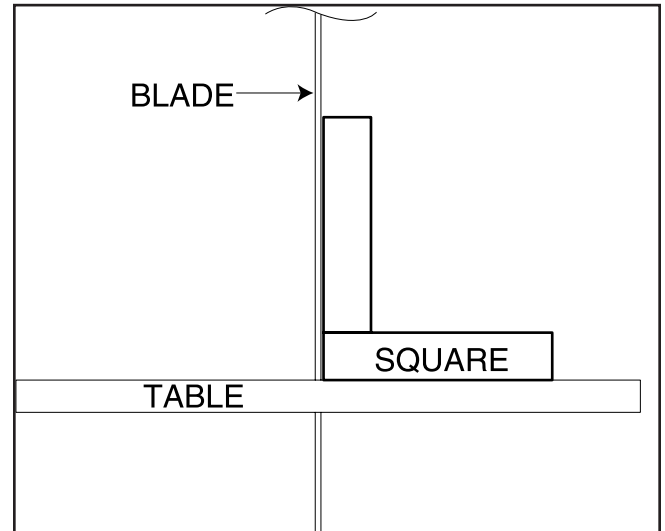

Figure 29. Squaring table to blade.

The table can be shifted side to side to properly align the miter slot and the blade:

1. Loosen the 6 trunnion bolts underneath the table.
2. Install the largest width blade available in the machine. Lay a straightedge along side the blade and inspect it closely to make sure it is parallel to the blade.

Make sure the straightedge doesn't deflect the blade. Measure the distance between the edge of the miter gauge slot and the straightedge at points **A** and **B**.

Distance **A** should be approximately equal to distance **B**. See **Figure 30**. Adjust the table slightly until these distances are equal.

3. Secure the table by retightening the trunnion bolts. Recheck table position to ensure that unwanted shifting did not occur during retightening.

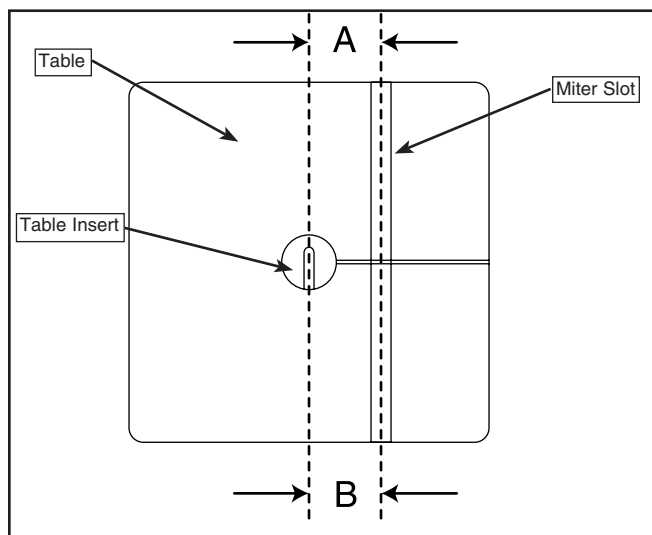

Figure 30. Squaring miter slot to blade.

The table should also be 90° to the back edge of the blade. If the table is not perpendicular to this edge, it may be necessary to shim the table in the desired direction with washers. Remove the trunnion bolts and add washers between the table and trunnion so the table tilts in the desired direction. Electrical washers are very thin and will allow fine adjustment.



Fence Adjustment

The fence can be adjusted slightly by applying pressure on the fence and skewing it in the desired direction. If the natural line of cut is too extreme, you may choose to slide the fence out of the way and clamp a pivot block to the table in place of the fence. When cutting irregular shapes, slide the fence completely out of the way. To adjust the fence:

1. Find a $\frac{3}{4}$ " scrap piece of wood roughly the same length as the saw fence and 2" or 3" wide.
2. Draw a line along the wide face and parallel with the edge.
3. Slide the fence out of the way and cut free-hand along the line, stopping at the halfway point. Turn the bandsaw off and wait for the blade to stop.
4. Without moving the scrap piece, temporarily clamp it to the bandsaw table.
5. Slide the fence against the scrap piece and adjust the fence so it is parallel with the scrap piece.



Blade Lead

Blade lead occurs when you are attempting a straight cut and the blade wanders to one side or the other. It is an inherent situation with all bandsaws and often occurs when using the fence. The reason this usually happens is (1) the blade tension isn't correct, (2) the teeth are dull on one side, or (3) the teeth are heavier on one side of the blade than the other.

If you don't have time to switch blades or readjust your bandsaw, you can temporarily compensate for blade lead by slightly rotating your table. To do this, rotate the table to match the angle that your blade is leading. Your purpose in doing this is to "trick" your bandsaw into cutting straight.



Test Run

Once assembly is complete, adjustments are done to your satisfaction and tools are safely put away, you are ready to test run the machine.

Turn on the power supply at the main panel. Press the START button on the switch. Make sure that your finger is poised on the switch to press the STOP button in case there's a problem. The bandsaw should run smoothly, with little or no vibration or rubbing noises. Strange or unnatural noises should be investigated and corrected before operating the machine further.

If you cannot easily locate the source of an unusual noise or vibration, contact our Service Department for help.



SECTION 6: OPERATIONS

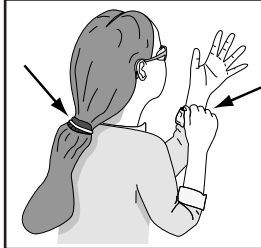

! WARNING

Keep clothing rolled up and out of the way of machinery and keep hair pulled back.

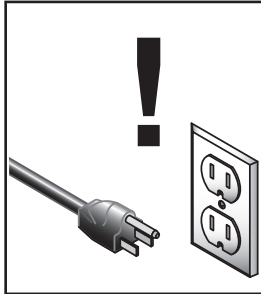

! WARNING

Disconnect power to the machine when performing any maintenance or assembly. Failure to do this may result in serious personal injury.



! WARNING

Wear safety glasses during all operations on the shaper. Failure to comply may result in serious personal injury.

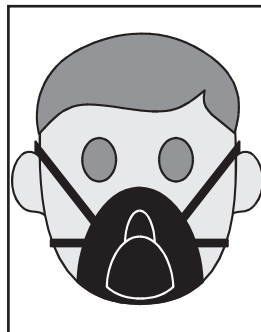

! CAUTION

Always wear a dust mask when operating the bandsaw. Using this machine produces sawdust which may cause allergic reactions or respiratory problems.

NOTICE

The following section was designed to give instructions on the basic operations of this bandsaw. However, it is in no way comprehensive of every bandsaw application. WE STRONGLY RECOMMEND that you read books, trade magazines, or get formal training to maximize the potential of your shaper. There are many different jigs that can be built to increase safety, accuracy, and types of cuts.

General

There are many interrelated adjustment points to consider when operating this type of saw. Therefore, cutting results can be somewhat unpredictable if some or all of the crucial adjustments are neglected. Here are a few simple things you can do to increase the performance predictability of your bandsaw:

1. Always use a sharp, high-quality blade.
2. Use the right blade for the job. Resawing with a $1/8$ " blade or doing scrollwork with a $3/4$ " blade are extreme examples of using the wrong blade for the job.
3. Allow the saw to cut. Don't force the workpiece into the blade. When cutting curves or irregular shapes, remember that the blade should still be cutting the wood. Simply turning the workpiece will only bind the blade and could cause it to break.
4. Maintain your bandsaw in top condition. See **Section 7** of this manual for maintenance procedures.

! WARNING

Do not force the wood into the blade during cutting. This will distort the blade, cause excessive heat and can often result in blade breakage which can cause laceration injuries. Feed the wood smoothly and slowly into the blade. Failure to exercise care can result in serious injury.



Blade Information

A bandsaw blade is a delicate piece of steel that is subjected to tremendous strain. Be sure you use quality blades of the proper width for the various types of cutting operations.

Always use the widest blade possible for the workpiece you are cutting. Use narrow blades only for sawing small, abrupt curves and for fine, delicate work. Bandsaw blades can be purchased welded, set and sharpened ready-for-use from most saw shops. We also supply bandsaw blades in widths of $\frac{1}{16}$ ", $\frac{1}{8}$ ", $\frac{3}{16}$ ", $\frac{1}{4}$ ", $\frac{3}{8}$ ", $\frac{1}{2}$ ", and $\frac{3}{4}$ ", for this saw. Please refer to our current catalog for prices and ordering information.

Always select and use good quality saw blades and choose the right blade for the job. Using a dull blade or selecting a poor quality blade or one not designed for the job at hand is often the cause of premature blade failure or unsatisfactory cutting results.

Many conditions may cause blade breakage. Breakage is, in some cases, unavoidable, since it is the natural result of the peculiar stresses that bandsaw blades are subjected to. Blade breakage is also due to avoidable causes. Avoidable breakage is most often the result of poor care or judgement on the part of the operator. The most common causes of blade breakage are: (1) faulty alignment and adjustment of the guides; (2) forcing or twisting a wide blade around a tight curve or short radius; (3) feeding too fast; (4) tooth dullness or absence of sufficient set; (5) excessive blade tension; (6) upper blade guide assembly set too high above the workpiece; (7) using a blade with a lumpy or improperly finished weld; and (8), continuously running the bandsaw when not in use.

The Grizzly G1019 14" Bandsaw uses 93 $\frac{1}{2}$ " blades.



Changing Blades

When removing or installing blades, make sure the power is disconnected and moving parts have come to a complete stop.

To remove the blade:

1. Back guide block assemblies and support bearings away from the blade and raise the guide post up and away from the table.
2. Release blade tension by turning the blade tension knob counterclockwise.
3. Remove table insert and tapered table pin.
4. Open top and bottom wheel covers.
5. Loosen the two blade guard mounting bolts and slide the guard off of the mounting studs.
6. Pull blade straight off the wheels, rotate 90° and feed along the table through the table slot.

To install the blade:

1. Hold the blade in both hands so the teeth of the blade in your right hand are pointing down.
2. Feed the blade into the slot in the table. Turn the blade 90° and position over the top and bottom wheels. The teeth of the blade must be pointing down toward the table.
3. Apply tension to the blade by turning the tension control knob. Rotate the upper wheel slowly by hand as tension is applied to allow the blade to center itself on the wheel. Adjust tracking if needed. See "Blade Tension" and "Blade Tracking" instructions for details.
4. Readjust upper and lower blade guides and support bearings.

5. Install the table taper pin and table insert.
6. Install the blade guard.
7. Close the top and bottom covers.

Ripping

Ripping is the process of cutting a board into two or more thinner boards, generally in a direction along its length. The maximum board width that can be ripped is limited by the distance between the blade and the support column. Maximum cutting width for this bandsaw is 13½".

Blade selection is an important consideration when ripping. Generally, the wider the blade, the better. In most applications, a hook or skip tooth style will be sufficient. Also, since most ripped lumber will be planed or sanded smooth, you can choose blades with fewer teeth-per-inch. While blades with fewer teeth-per-inch produce rougher cuts, these types of blades offer larger gullet capacities for clearing sawdust, less heat buildup, and more horsepower per tooth.

Be aware that blade lead is an inherent situation with all bandsaws during ripping operations that involve using the fence. Consult with the "Blade Lead" instructions on why this happens and what you can do about it.

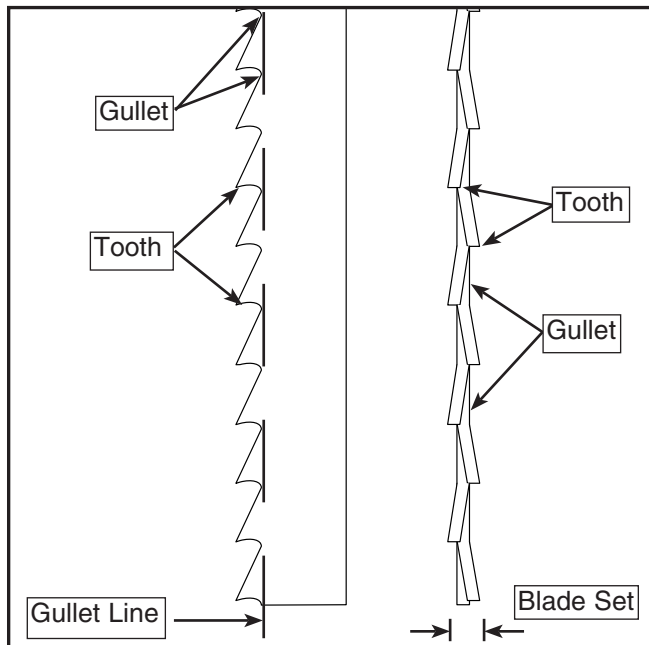

Figure 31. Side and front views of a standard bandsaw blade.

CAUTION

The bandsaw blade is dangerously sharp. Use extreme caution when working near the saw blade. Failure to exercise care could result in severe injury.



To perform ripping operations:

1. The bandsaw must be adjusted correctly. See "Blade Tension/Tracking" instructions.
2. The table must be square to the blade. See "Table Adjustment" instructions.
3. Use the widest blade available. The blade must also be in good condition.
4. Use a fence to guide work.
5. Draw a reference line on the edge of the board.
6. Support ends of the board if necessary.
7. Feed work slowly and evenly.



Stacked Cuts

One of the benefits of a bandsaw is its ability to cut multiple copies of a particular shape by stacking a number of workpieces together.

Before making stacked cuts, it is essential to ensure that both the table and the blade are properly adjusted to 90°. Otherwise, any error will be compounded with each piece cut from the top to the bottom of the stack.

To complete a stacked cut:

1. Align your pieces from top to bottom to ensure that each piece has adequate scrap to provide a clean, unhampered cut.
2. Using brads in the waste portion of each piece, secure all the pieces together.
3. Lay out the shape you intend to cut on the face of the top piece.
4. Make relief cuts perpendicular to the outline of your intended shape in areas where changes in blade direction could strain the woodgrain or cause the blade kerf to bind.
5. Cut the stack of pieces as though you were cutting a single piece. Follow your layout line with the blade kerf on the waste side of your line.



Cutting Curves

When cutting curves, simultaneously feed and turn the stock carefully so that the blade follows the layout line without being twisted. If a curve is so abrupt that it is necessary to repeatedly back up and cut a new kerf, use either a narrower blade or a blade with more set.

Always make short cuts first, then proceed to the longer cuts. Relief cuts will also reduce the chance that the blade will be pinched or twisted. Relief cuts are made through the waste portion of the workpiece and are stopped at the layout line. As you cut along the layout line, waste wood is released from the workpiece, alleviating any pressure on the back of the blade. Relief cuts also make backing the workpiece out easier, if needed. **Figure 32** lists blade widths and the corresponding minimum radii each blade will cut.

BLADE WIDTH	MINIMUM RADII
1/16"	1/8"
1/8"	3/16"
3/16"	5/16"
1/4"	5/8"
3/8"	1 1/2"
1/2"	2 1/2"
5/8"	4"
3/4"	5 1/2"

Figure 32. Minimum circle radius vs. blade size.



Circle Cut Attachment

The circle cutting attachment is standard equipment with the Model G1019 Bandsaw. The attachment is fully adjustable and is capable of producing circles up to 12" in diameter in 3" thick stock. To mount the circle cutting attachment:

Insert the circle cutting attachment into the hole in the bandsaw table. Loosely thread the locking bolt into position. **Figure 33.**

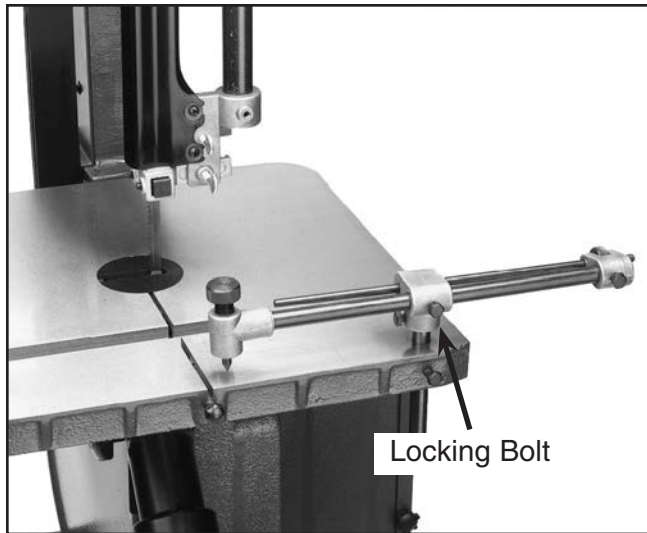

Figure 33. Circle cutting locking bolt.

To adjust the circle cutting attachment (See **Figure 34**):

1. Set the height of the whole attachment so your stock will fit just under the pivot point. Secure the locking bolt #1.
2. Determine the radius of the circle you wish to cut and measure from the front of the band saw blade along the blade groove in the table.

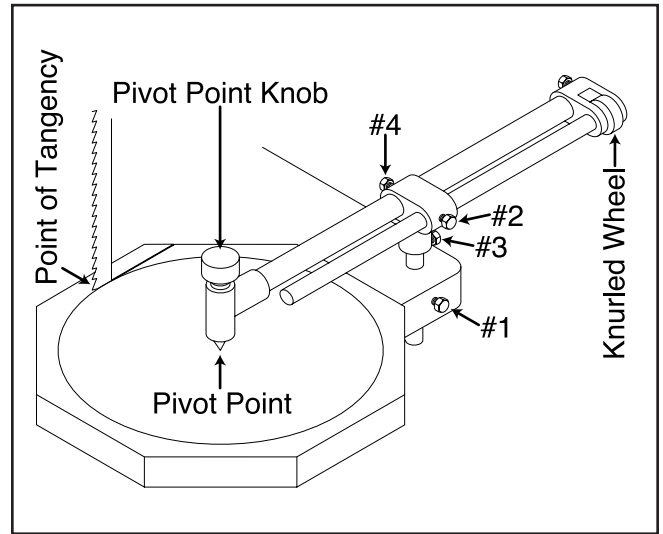

Figure 34. Circle cutting jig at work.

4. Tighten locking bolt #2. Fine tune by turning the knurled wheel.
5. After all positioning adjustments have been made, tighten locking bolts #3 and #4.

To cut a circle:

1. Ensure that the bandsaw is adjusted correctly and all safety precautions are observed.
2. Determine a point of tangency on your stock and cut to that point. NOTE: On larger circles, it may be necessary to trim off the corners of your stock as shown in **Figure 34**.
3. Turn the pivot point knob so the pivot point sets into the stock.
4. Finish cutting the circle. Let the circle-cutting attachment guide the stock.



Resawing

Resawing is the process of cutting a board along its thickness into two or more thinner boards. Each new board is the same width and length as the original board, but the thickness is less. The maximum board width that can be resawn on this bandsaw is 6¹/₄".

Although the Model G1019 Bandsaw was not specifically designed for resawing, it is capable of resawing when the saw is set up properly. Use common sense – attempting to resaw a board that is too wide or too dense may put excessive strain on the blade and be unsafe.

Similar to ripping, blade selection is an important consideration when resawing. When selecting a blade, keep in mind that a wider blade is easier to control. The blade should be of high quality in order to handle the increased stress. In most applications a hook or skip tooth style will work fine.

WARNING

Do not force the wood into the blade during cutting. This will distort the blade, cause excessive heat and can often result in blade breakage which can cause laceration injuries. Feed the wood smoothly and slowly into the blade. Failure to exercise care can result in serious injury.

Also, since most resawn lumber will be planed smooth, you can choose blades with fewer teeth per inch (3 to 6). These types of blades offer larger gullet capacities for clearing sawdust. They also produce less heat build up and yield more horsepower per tooth.

To resaw lumber, follow the procedure below:

1. The blade must be adjusted correctly and the table must be square to the blade. See Adjustment section.
2. Use the widest blade that will fit this saw (³/₄"). The blade must also be in good condition.
3. Use the fence or a pivot block to guide the work. If using a pivot block, clamp the block to the table next to the fence at the desired distance from the blade and mark the line of cut on the workpiece. Follow the mark during cutting while using the pivot block as a guide.
4. Feed work slowly and evenly.

If the blade wanders off the line of cut when using the fence, you may be experiencing blade lead. Read the "Blade Lead" section for ideas on why this happens and what you can do about it.



SECTION 7: MAINTENANCE

General

Regular periodic maintenance on your Model G1019 Bandsaw will ensure its optimum performance. Make a habit of inspecting your bandsaw each time you use it. Check for the following conditions and repair or replace when necessary.

1. Loose mounting bolts.
2. Worn switch.
3. Worn or damaged cords and plugs.
4. Damaged V-belt.
5. Any other condition that could hamper the safe operation of this machine.

Always perform any maintenance with the power off and the machine unplugged.



Table

The table and other non-painted surfaces on the Model G1019 should be protected against rust and pitting. Wiping the saw clean after every use ensures that moisture from wood dust isn't allowed to trap moisture against bare metal surfaces.

Some woodworkers recommend using automotive paste wax on exposed steel and cast iron surfaces. The wax provides a layer of protection, as well as reducing friction between lumber and the table, making cuts faster and smoother. Avoid waxes that contain silicone or other synthetic ingredients. These materials can find their way into lumber that's being worked, and can make staining and finishing difficult. If you use paste wax, make sure that it's 100% Carnauba wax.



Bearings

Since all bearings are shielded and permanently lubricated, no maintenance is required on them. If after a period of time you notice a distinct noise or rumble coming from a shielded bearing, or the bearing journal is hot to the touch after use, it will be time to replace the shielded bearing assembly(s). Please contact our Customer Service number to order replacement bearings or to make arrangements to send your bandsaw back for service.



V-Belt

Inspect V-belt regularly for tension and wear. Replace when necessary. Check pulleys to ensure that they are properly aligned and securely tightened. See "Motor Assembly" instructions for proper tension and pulley alignment procedures.

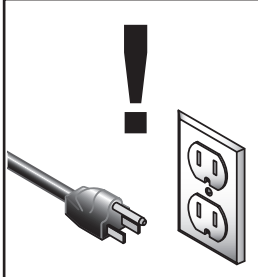
	<p>⚠ WARNING Disconnect power to the machine when performing any maintenance or assembly. Failure to do this may result in serious personal injury.</p>
--	--



SECTION 8: CLOSURE

The following pages contain general machine data, parts diagrams/lists, troubleshooting guide and Warranty/Return information for your Model G1019 Bandsaw.

If you need parts or help in assembling your machine, or if you need operational information, we encourage you to call our Service Department. Our trained service technicians will be glad to help you. If you have comments dealing specifically with this manual, please write to our Bellingham, Washington location using the address in the **General Information** section.

The specifications, drawings, and photographs illustrated in this manual represent the Model G1019 Bandsaw as supplied when this manual was prepared. However, due to Grizzly's policy of continuous improvement, changes may be made at any time with no obligation on the part of Grizzly to prior customers. Whenever possible, though, we send manual updates to all owners of a particular tool or machine. Should you receive one, add the new information to this manual and keep it for future reference.

We have included some important safety measures that are essential to this machine's operation. While most safety measures are generally universal, Grizzly reminds you that each workshop is different and safety rules should be considered *as they apply to your specific situation*.

WARNING

As with all power tools, there is danger associated with the Model G1019 Bandsaw. Use the tool with respect and caution to lessen the possibility of mechanical damage or operator injury. If normal safety precautions are overlooked or ignored, injury to the operator or others in the area is likely.



We recommend you keep a copy of our current catalog for complete information regarding Grizzly's warranty and return policy. If you need additional technical information relating to this machine, or if you need general assistance or replacement parts, please contact our Service Department.

We recommend reviewing additional information sources to realize the full potential of this machine. Trade journals, woodworking magazines, and your local library are good places to start.

WARNING

The Model G1019 was specifically designed for wood cutting operations. **DO NOT MODIFY AND/OR USE THIS BANDSAW FOR ANY OTHER PURPOSE.** Modifications or improper use of this tool will void the warranty. If you are confused about any aspect of this machine, **DO NOT** use it until all your questions have been answered. Serious personal injury may occur.

WARNING

Operating this equipment has the potential for flying debris to cause eye injury. Always wear safety glasses or goggles when operating equipment. Everyday glasses or reading glasses only have impact resistant lenses, they are not safety glasses. Be certain the safety glasses you wear meet the appropriate standards of the American National Standards Institute (ANSI).

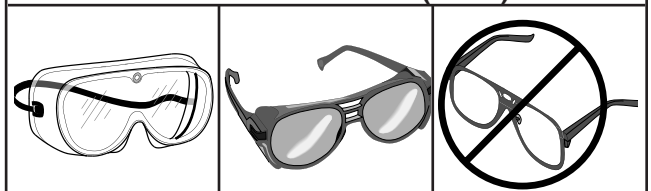

Wiring Diagram

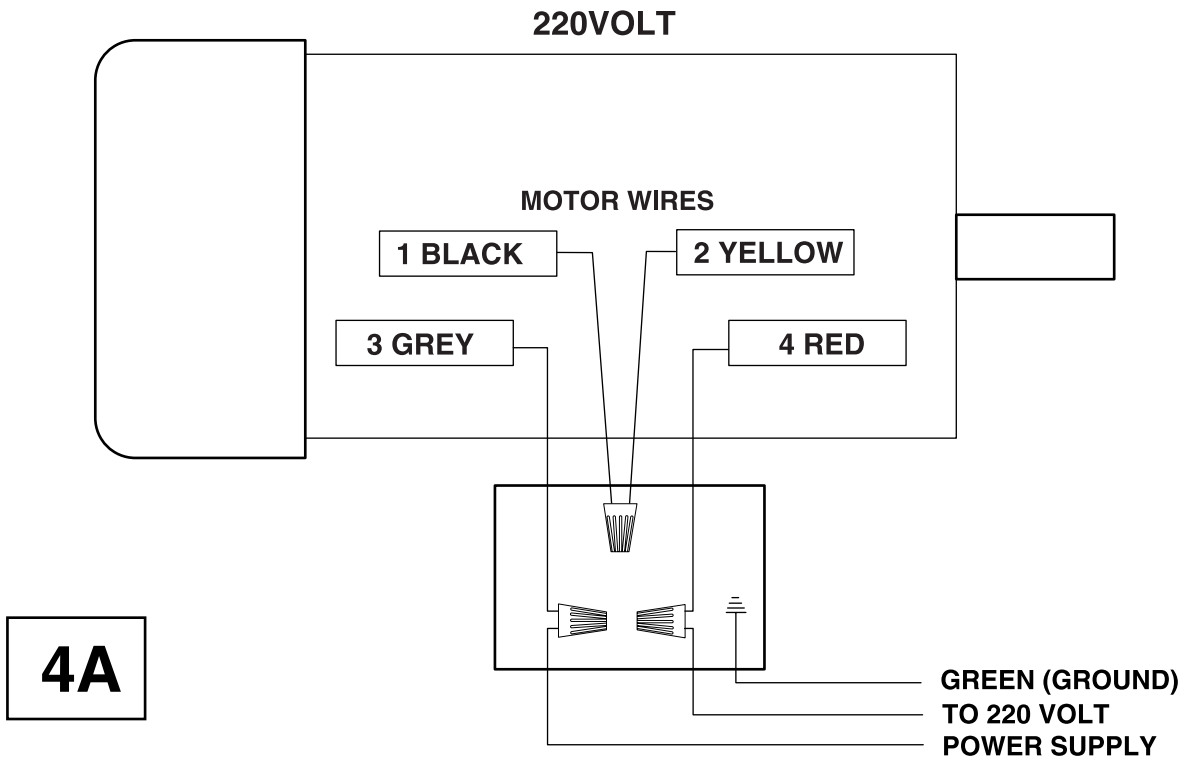
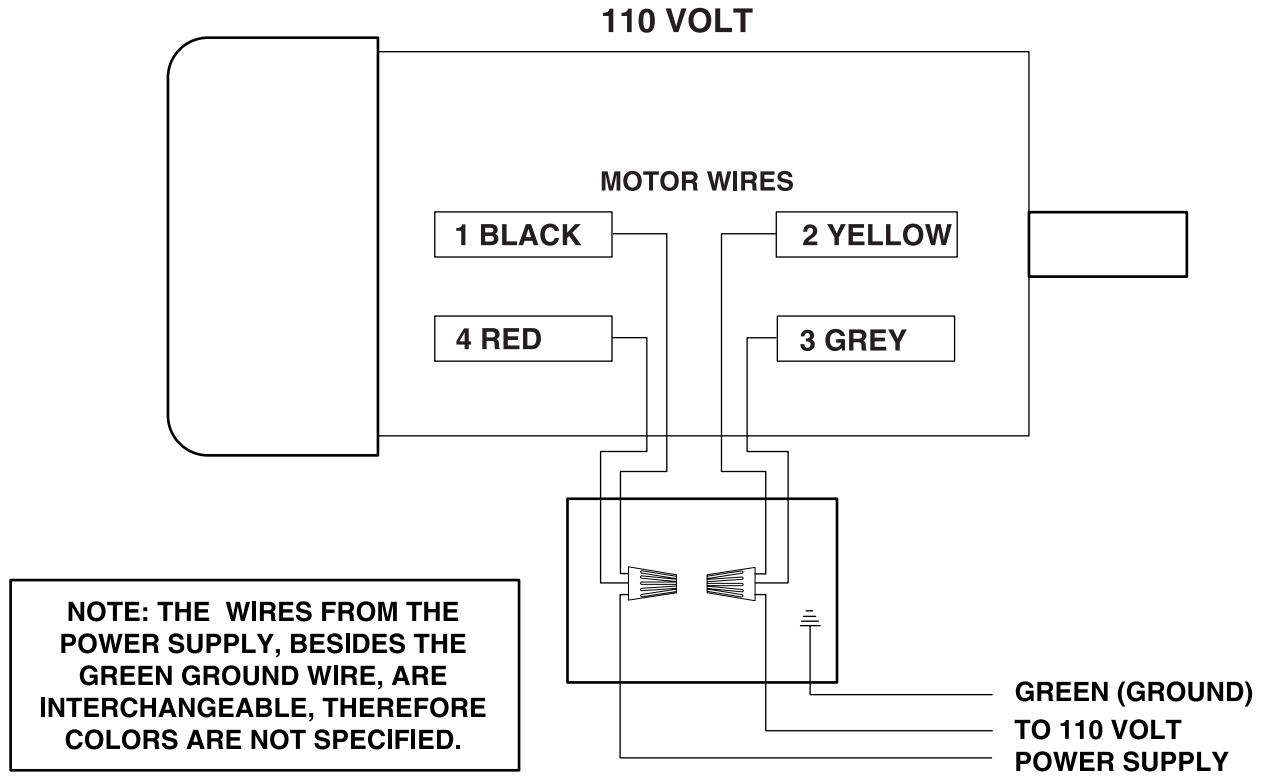



MACHINE DATA SHEET

Customer Service #: (570) 546-9663 • To Order Call: (800) 523-4777 • Fax #: (800) 438-5901

GRIZZLY MODEL G1019 14" BANDSAW

Overall Dimensions:

Table	14" x 14" x 1 1/4" Thick
Height	65"
Height From Floor to Table	43"
Width of Unit	24 1/4"
Depth of Unit	20 1/2"
Shipping Weight	203 lbs.
Weight in Place	195 lbs.
Box Size	44 3/4" L x 22" W x 13" H
Foot Print	17 1/2" x 19 1/2"

Cutting Capacity:

Left of Blade	13 1/2"
Height	6 1/4"
Table Tilt	10° Left; 45° Right

Construction:

Table	Precision Ground Cast Iron
Wheels	Balanced Cast Aluminum with Rubber Tires
Rip Fence	Formed Steel and Bar Stock
Wheel Covers	Pre-Formed Steel
Guides	Steel Guide Blocks with Ball Bearing Rear Blade Support
Stand	Pre-Formed Steel

Motor:

Type	TEFC Capacitor Start Induction
Horsepower	3/4 H.P.
Phase / Cycle	Single-Phase / 60 Hz
Voltage	110V / 220V
Prewired	110V
Amps	11 / 5.5
R.P.M.	1720
Bearings	Shielded & Lubricated Ball Bearing
Switch	On/Off Mechanical Push Button
Power Transfer	V-Belt

Blades:

Sizes Available	From 1/16" to 3/4"
Standard Blade Length	93 1/2"
Blade Speed	3300 F.P.M.

Accessories:

..... Includes Fence, Miter Gauge, Circle-Cutting Attachment & 3/8" Blade

Optional Equipment:

Model G1127 Extension Block Kit. This adds six more inches to the maximum cutting height. Included in the Kit is a 3/8" x 105" blade and instructions for installation. See the current Grizzly catalog for more details.

Specifications, while deemed accurate, are not guaranteed.

TROUBLESHOOTING

SYMPTOM	POSSIBLE CAUSE	CORRECTIVE ACTION
Motor will not start.	<ol style="list-style-type: none"> 1. Low voltage. 2. Open circuit in motor or loose connections. 	<ol style="list-style-type: none"> 1. Check power line for proper voltage. 2. Inspect all lead connections on motor for loose or open connections.
Motor will not start; fuses or circuit breakers blow.	<ol style="list-style-type: none"> 1. Short circuit in line cord or plug. 2. Short circuit in motor or loose connections. 3. Incorrect fuses or circuit breakers in power line. 	<ol style="list-style-type: none"> 1. Inspect cord or plug for damaged insulation and shorted wires. 2. Inspect all connections on motor for loose or shorted terminals or worn insulation. 3. Install correct fuses or circuit breakers.
Motor overheats.	<ol style="list-style-type: none"> 1. Motor overloaded. 2. Air circulation through the motor restricted. 	<ol style="list-style-type: none"> 1. Reduce load on motor. 2. Clean out motor to provide normal air circulation.
Motor stalls (resulting in blown fuses or tripped circuit).	<ol style="list-style-type: none"> 1. Short circuit in motor or loose connections. 2. Low voltage. 3. Incorrect fuses or circuit breakers in power line. 4. Motor overloaded. 	<ol style="list-style-type: none"> 1. Inspect connections on motor for loose or shorted terminals or worn insulation. 2. Correct the low voltage conditions. 3. Install correct fuses or circuit breakers. 4. Reduce load on motor.
Machine slows when operating.	<ol style="list-style-type: none"> 1. Applying too much pressure to workpiece. 2. Blade is dull. 	<ol style="list-style-type: none"> 1. Feed workpiece slower. 2. Replace blade.
Blade does not run evenly on wheels or runs off.	<ol style="list-style-type: none"> 1. Tracking is not adjusted properly. 2. Rubber tire on wheel is damaged or worn. 3. Wheels are not coplanar. 	<ol style="list-style-type: none"> 1. Adjust tracking. 2. Replace rubber tires. 3. Adjust wheel coplanarity.
Blade does not cut evenly.	<ol style="list-style-type: none"> 1. Blade tension is incorrect. 2. Tooth set is uneven. 3. Teeth are sharper on one side than the other. 	<ol style="list-style-type: none"> 1. Adjust tension. 2. Replace blade, or have it professionally sharpened. 3. Replace blade, or have it professionally sharpened.
Ticking sound when the saw is running.	<ol style="list-style-type: none"> 1. Blade weld contacting support bearing. 2. Blade weld may be failing. 	<ol style="list-style-type: none"> 1. Use file or stone to smooth and round the back of the blade. 2. Inspect and replace blade if necessary.
Blade contacting table insert.	<ol style="list-style-type: none"> 1. Excessive side pressure when cutting. 2. Table improperly adjusted. 	<ol style="list-style-type: none"> 1. Reduce side pressure. 2. Adjust table.
Excessive vibration.	<ol style="list-style-type: none"> 1. Wheels not coplanar. 2. Tires incorrectly installed. 3. Bent or worn out blade. 4. Wheels out of balance. 	<ol style="list-style-type: none"> 1. Adjust wheels coplanar. 2. Re-install tires. 3. Replace blade. 4. Replace wheels.
Burn marks on the edge of the cut.	<ol style="list-style-type: none"> 1. Too much side pressure when feeding workpiece. 2. Blade too wide for size of radius being cut. 	<ol style="list-style-type: none"> 1. Feed workpiece straight into the blade. 2. Install a smaller width blade, and/or increase blade tension.

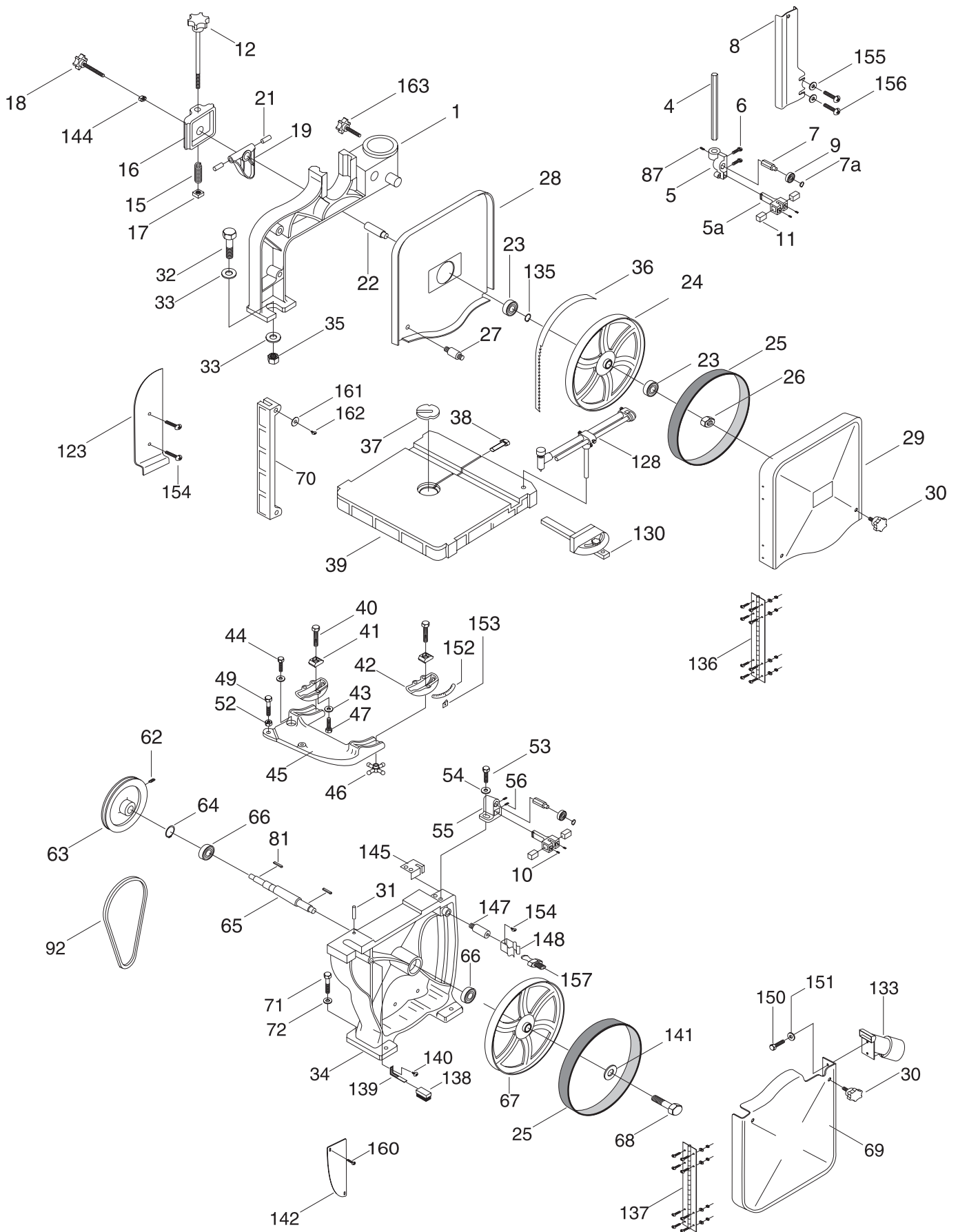

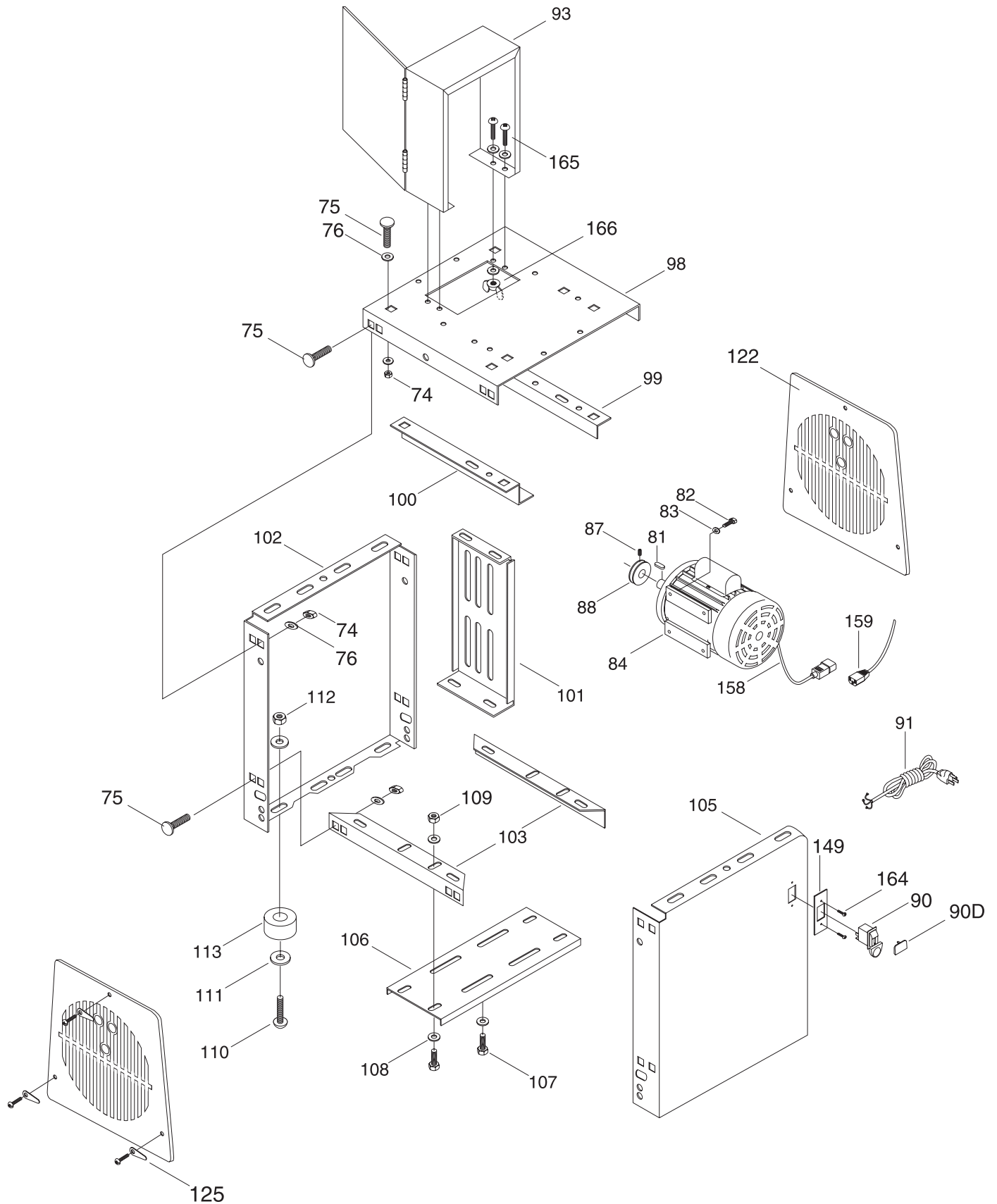

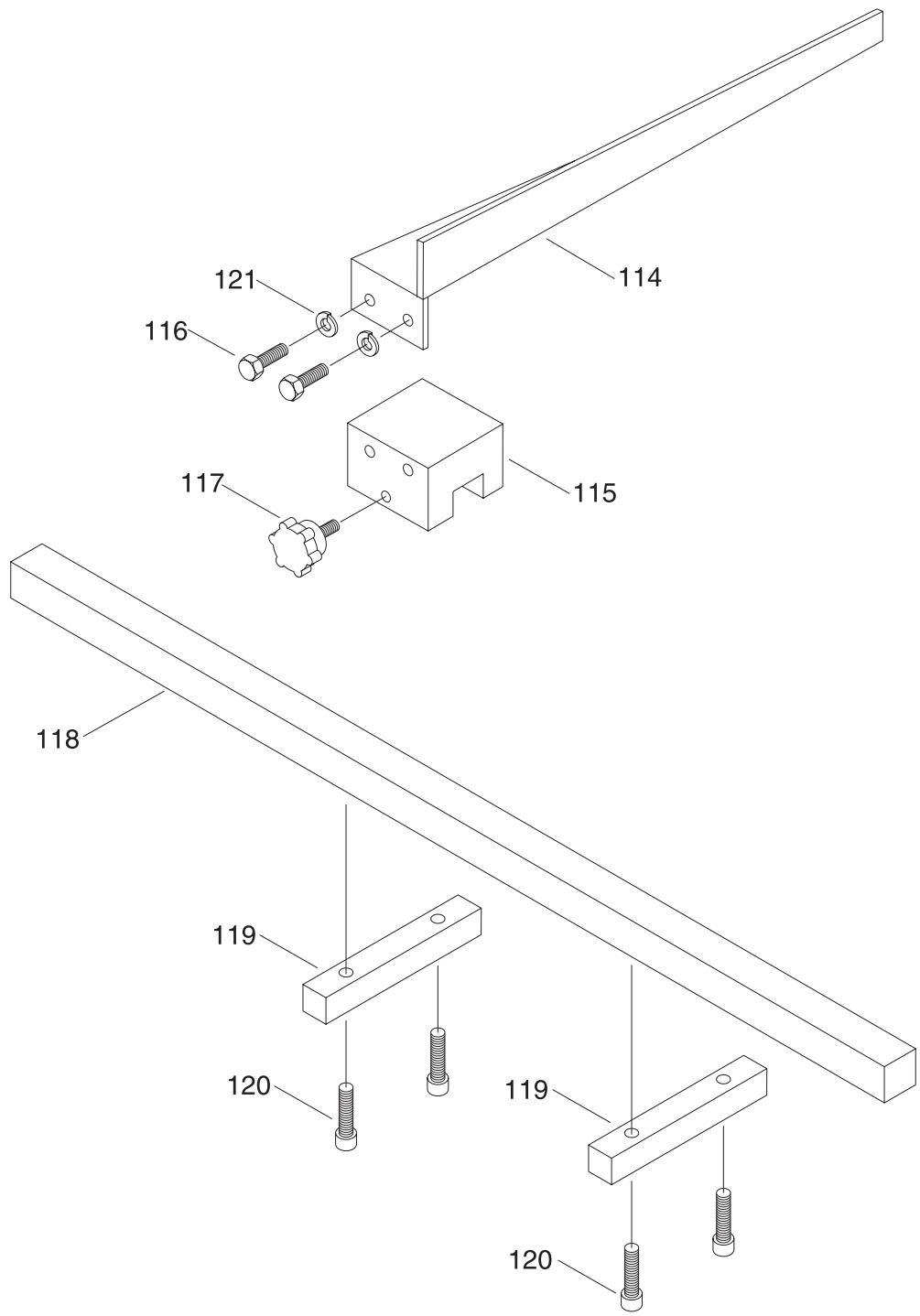

REF	PART #	DESCRIPTION
01	P1019001A	UPPER FRAME ARM
04	P1019004A	GUIDE POST
05	P1019005	GUIDE SUPPORT BRACKET
05A	P1019005A	GUIDE BLOCK HOLDER
06	P1019006	KNOB SCREW
07	P1019007	UPPER SPACING SLEEVE
07A	P101907A	SNAP RING 10mm
08	P1019008	BLADE GUARD
09	P1019009	BEARING 6200-2RS
10	P1019010	SETSCREW M6-1.0X10mm
11	P1019011	BLADE GUIDE BLOCK
12	P1019012	TENSION KNOB
15	P1019015	SPRING
16	P1019016	SLIDING BRACKET
17	P1019017	SQUARE NUT 3/8"-16
18	P1019018	ADJUSTMENT KNOB
19	P1019019	SHAFT HINGE
21	P1019021	STEEL PIN
22	P1019022	UPPER WHEEL SHAFT
23	P1019023	BEARING 6202-2RS
24	P1019024	UPPER WHEEL
25	P1019025	TIRE
26	P1019026	HEX NUT 1/2"-20
27	P1019027	STUD
28	P1019028A	UPPER GUARD, INSIDE
29	P1019029A	UPPER GUARD, OUTER
30	P1019030A	KNOB
31	P1019031	SET PIN
32	P1019032	HEX BOLT 3/4"-10 X 2 1/2"
33	P1019033	FLAT WASHER 3/4"
34	P1019034A	BASE
35	P1019035	HEX NUT 3/4"-10
36	P1019036	BLADE
37	P1019037	TABLE INSERT
38	P1019038	TABLE PIN
39	P1019039	TABLE

REF	PART #	DESCRIPTION
40	P1019040	SPECIAL HEX BOLT
41	P1019041	TRUNNION CLAMP SHOE
42	P1019042	TRUNNION
43	P1019043	FLAT WASHER 1/4"
44	P1019044	HEX BOLT 1/4"-20 X 5/8"
45	P1019045	TRUNNION SUPPORT BRKT
46	P1019046	STAR WHEEL KNOB
47	P1019047	HEX BOLT 5/16"-18 X 1"
48	P1019048	FLAT WASHER 5/16"
49	P1019049	HEX BOLT 5/16"-18 X 3"
52	P1019052	HEX NUT 5/16"-18
53	P1019053	HEX BOLT 1/4"-20 X 3/4"
54	P1019054	FLAT WASHER 1/4"
55	P1019055	LOWER GUIDE SUPPORT
56	P1019056	SETSCREW M6-1.0X10mm
57	P1019057	WASHER
58	P1019058	SCREW
60	P1019060	SETSCREW M6-1.0X10mm
61	P1019061	KEY 5X5X23
62	P1019062	SETSCREW M6-1.0X10mm
63	P1019063	PULLEY
64	P1019064	SNAP RING 20mm
65	P1019065	SHAFT
66	P1019066	BEARING 6204-2RS
67	P1019067	LOWER WHEEL
68	P1019068	HEX NUT 3/4"-16
69	P1019069A	LOWER WHEEL GUARD
70	P1019070	GUARD
71	P1019071	HEX BOLT 5/16"-18 X 2"
72	P1019072	FLAT WASHER 5/16"
74	P1019074	HEX NUT 5/16"-18
75	P1019075	CARR BOLT 5/16"-18 X 5/16"
76	P1019076	FLAT WASHER 5/16"
79	P1019079	FLAT WASHER 5/16"
81	P1019081	KEY
82	P1019082	HEX BOLT 5/16"-18 X 3/4"

REF	PART #	DESCRIPTION
83	P1019085	FLAT WASHER 5/16"
84	P1019084	MOTOR
86	P1019086	HEX NUT 5/16"-18
87	P1019087	SETSCREW M6-1.0X10mm
88	P1019088	MOTOR PULLEY
90	P1019090A	SWITCH
90D	P1019090D	SWITCH KEY
91	P1019091	POWER CORD
92	P1019092	V-BELT A-51
93	P1019093	PULLEY COVER
96	P1019096	FLAT WASHER #10
98	P1019098	TOP PANEL
99	P1019099	RIGHT ANGLE BRACE
100	P1019100	DOUBLE BEND BRACE
101	P1019101	MOTOR MOUNT PLATE
102	P1019102	REAR PANEL
103	P1019103	STAND BRACE
105	P1019105	FRONT PANEL
106	P1019106	MOTOR SUPPORT PLATE
107	P1019107	HEX BOLT 5/16"-18 X 3/4"
108	P1019108	FLAT WASHER 5/16"
109	P1019109	HEX NUT 5/16"-18
110	P1019110	PHLP HD SCR 1/4"-20 X 3/4"
111	P1019111	FLAT WASHER 1/4"
112	P1019112	HEX NUT 1/4"-20
113	P1019113	RUBBER FOOT
114	P1019114	FENCE
115	P1019115	FENCE GUIDE BLOCK
116	P1019116	HEX BOLT M6-1.0X12mm
117	P1019117	KNOB
118	P1019118A	GUIDE RAIL
119	P1019119	MOUNT BRACKET
120	P1019120	CAP SCREW M6-1.0X16MM
121	P1019121	LOCK WASHER 5/16"
122	P1019122	STAND COVER

REF	PART #	DESCRIPTION
123	P1019123	FRAME ARM COVER
128	P1019128	CIRCLE CUTTING ATT.
130	P1019130	MITER GAUGE
133	P1019133	DUST CHUTE
134	P1019134	SCREW
135	P1019135	INT RETAINING RING 35
136	P1019136	DOOR HINGE UPPER
137	P1019137	DOOR HINGE LOWER
138	P1019138	BRUSH
139	P1019139	BRUSH BRACKET
140	P1019140	SELFTAP SCRW 10-24X 3/8"
141	P1019141	FLAT WASHER
142	P1019142	FRAME ARM COVER, LWR
144	P1019144	HEX NUT 5/16"-18
145	P1019145	BLADE GUARD LOWER
147	P1019147	STUD, DOOR
148	P1019148	CLIP HEAD
149	P1019149	SWITCH PLATE
150	P1019149	HEX SCREW 1/4"-20 X 1/4"
151	P1019151	FLAT WASHER 1/4"
152	P1019152	SCALE
153	P1019153	POINTER
154	P1019154	SCREW
155	P1019155	FLAT WASHER
156	P1019156	PHLP HD SCR 10-24 X 3/8"
157	P1019157	BALL STUD
158	P1019158	POWER CORD W/RECP
159	P1019159	POWER CORD W/PLUG
160	P1019160	HEX HEAD BOLT
161	P1019161	FLAT WASHER
162	P1019162	PHILLIPS HEAD SCREW
163	P1019163	GUIDE SHAFT KNOB
164	P1019164	PHLP HD SCR 10-24 X 3/8"
165	P1019165	PHLP HD SCR 10-24 X 1/2"
166	P1019166	WING NUT 10-24

WARRANTY AND RETURNS

Grizzly Imports, Inc. warrants every product it sells for a period of 1 year to the original purchaser from the date of purchase. This warranty does not apply to defects due directly or indirectly to misuse, abuse, negligence, accidents, repairs or alterations or lack of maintenance. This is Grizzly's sole written warranty and any and all warranties that may be implied by law, including any merchantability or fitness, for any particular purpose, are hereby limited to the duration of this written warranty. We do not warrant or represent that the merchandise complies with the provisions of any law or acts unless the manufacturer so warrants. In no event shall Grizzly's liability under this warranty exceed the purchase price paid for the product and any legal actions brought against Grizzly shall be tried in the State of Washington, County of Whatcom.

We shall in no event be liable for death, injuries to persons or property or for incidental, contingent, special, or consequential damages arising from the use of our products.

To take advantage of this warranty, contact us by mail or phone and give us all the details. We will then issue you a "Return Number," which must be clearly posted on the outside as well as the inside of the carton. We will not accept any item back without this number. Proof of purchase must accompany the merchandise.

The manufacturers reserve the right to change specifications at any time because they constantly strive to achieve better quality equipment. We make every effort to ensure that our products meet high quality and durability standards and we hope you never need to use this warranty.

Please feel free to write or call us if you have any questions about the machine or the manual.

Thank you again for your business and continued support. We hope to serve you again soon.

WARRANTY CARD

Name _____
 Street _____
 City _____ State _____ Zip _____
 Phone Number _____ E-Mail _____ FAX _____
 MODEL # G1019 14" Bandsaw Order # _____

The following information is given on a voluntary basis. It will be used for marketing purposes to help us develop better products and services. Of course, all information is strictly confidential.

CUT ALONG DOTTED LINE

1. How did you learn about us?
 Advertisement Friend
 Catalog Card Deck
 World Wide Web
 Other _____
2. Which of the following magazines do you subscribe to.
 American Woodworker Practical Homeowner
 Cabinetmaker Shop Notes
 Family Handyman Today's Homeowner
 Fine Homebuilding WOOD
 Fine Woodworking Wooden Boat
 Home Handyman Woodshop News
 Journal of Light Construction Woodsmith
 Old House Journal Woodwork
 Popular Mechanics Woodworker
 Popular Science Woodworker's Journal
 Popular Woodworking Workbench
 Other _____
3. Which of the following woodworking/remodeling shows do you watch?
 Backyard America The New Yankee Workshop
 Home Time This Old House
 The American Woodworker Woodwright's Shop
 Other _____
4. What is your annual household income?
 \$20,000-\$29,999 \$60,000-\$69,999
 \$30,000-\$39,999 \$70,000-\$79,999
 \$40,000-\$49,999 \$80,000-\$89,999
 \$50,000-\$59,999 \$90,000 +
5. What is your age group?
 20-29 50-59
 30-39 60-69
 40-49 70 +
6. How long have you been a woodworker?
 0 - 2 Years 8 - 20 Years
 2 - 8 Years 20+ Years
7. How would you rank your woodworking skills?
 Simple Advanced
 Intermediate Master Craftsman
8. What stationary woodworking tools do you own? Check all that apply.
 Air Compressor Panel Saw
 Band Saw Planer
 Drill Press Power Feeder
 Drum Sander Radial Arm Saw
 Dust Collector Shaper
 Horizontal Boring Machine Spindle Sander
 Jointer Table Saw
 Lathe Vacuum Veneer Press
 Mortiser Wide Belt Sander
 Other _____
9. How many of your woodworking machines are Grizzly? _____
10. Which benchtop tools do you own? Check all that apply.
 1" x 42" Belt Sander 6" - 8" Grinder
 5" - 8" Drill Press Mini Lathe
 8" Table Saw 10" - 12" Thickness Planer
 8" - 10" Bandsaw Scroll Saw
 Disc/Belt Sander Spindle/Belt Sander
 Mini Jointer
 Other _____
11. How many of the machines checked above are Grizzly? _____
12. Which portable/hand held power tools do you own? Check all that apply.
 Belt Sander Orbital Sander
 Biscuit Joiner Palm Sander
 Circular Saw Portable Planer
 Detail Sander Saber Saw
 Drill/Driver Reciprocating Saw
 Miter Saw Router
 Other _____
13. What machines/supplies would you like Grizzly Industrial to carry?
 12" Table Saw Radial Arm Saw
 12" Jointer Panel Saw
 Combination Planer/Jointer Brass Hardware
 Paint & Finishing Supplies Lumber
 Contractor's Supplies
 Other _____
14. What new accessories would you like Grizzly Industrial to carry?
 Builders Hardware Hand Tools
 Fasteners Wood Components
 Other _____
15. What other companies do you purchase your tools and supplies from?

16. Do you think your purchase represents good value?
 Yes No
17. Would you recommend Grizzly Industrial to a friend?
 Yes No
18. Would you allow us to use your name as a reference for Grizzly customers in your area? Note: We never use names more than three times.
 Yes No
19. Comments: _____

FOLD ALONG DOTTED LINE

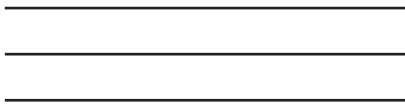

Place
Stamp
Here



GRIZZLY INDUSTRIAL, INC.
P.O. BOX 2069
BELLINGHAM, WA 98227-2069



FOLD ALONG DOTTED LINE

Send a Grizzly Catalog to a friend:

Name _____
Street _____
City _____ State _____ Zip _____

TAPE ALONG EDGES--PLEASE DO NOT STAPLE

