

READ THIS FIRST

Grizzly
Industrial, Inc.®

For questions or help with this product contact Tech Support at (570) 546-9663 or techsupport@grizzly.com

Model G0592

*****IMPORTANT UPDATE*****

For Machines Mfd. Since 09/24
and Owner's Manual Revised 12/22

The following changes were recently made since the owner's manual was printed:

- Coolant pump changed.

Aside from this information, all other content in the owner's manual applies and **MUST** be read and understood for your own safety. **IMPORTANT: Keep this update with the owner's manual for future reference.**

For questions or help, contact our Tech Support at (570) 546-9663 or techsupport@grizzly.com.

New Coolant Pump



Old Coolant Pump



COPYRIGHT © AUGUST, 2024 BY GRIZZLY INDUSTRIAL, INC.
**WARNING: NO PORTION OF THIS MANUAL MAY BE REPRODUCED IN ANY SHAPE
OR FORM WITHOUT THE WRITTEN APPROVAL OF GRIZZLY INDUSTRIAL, INC.**
#CS23321 PRINTED IN TAIWAN

Revised Specifications

Electrical:

Full-Load Current Rating..... 15.23A

Motors:

Coolant Pump

Horsepower..... 1/8 HP
 Phase..... Single-Phase
 Amps..... 0.23A
 Type..... Sealed Induction
 Power Transfer..... Direct
 Bearings..... Shielded & Permanently Lubricated

Revised Coolant Pump Wiring

COOLANT PUMP MOTOR 220V

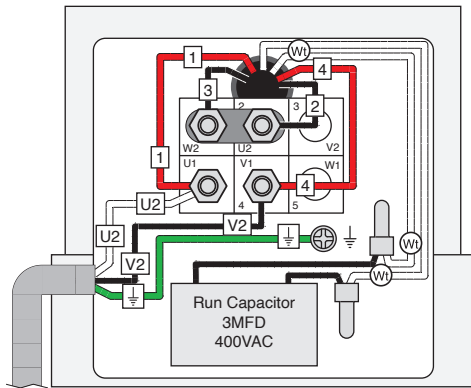

To Electrical Box



Figure 1. Pump motor wiring.

Revised Parts

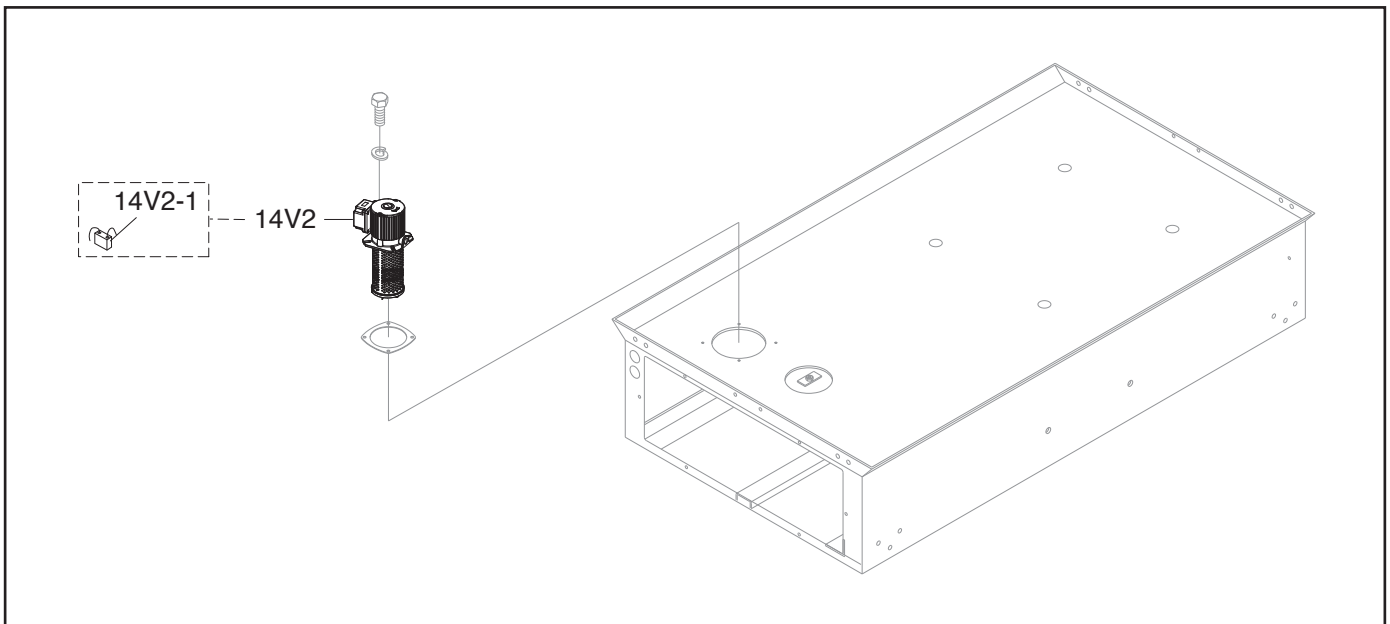

REF	PART #	DESCRIPTION
14V2	P0592014V2	COOLANT PUMP 1/8HP 220V 1PH V2.09.24

REF	PART #	DESCRIPTION
14V2-1	P0592014V2-1	R CAPACITOR 3M 400V



SECTION 2: POWER SUPPLY

Availability

Before installing the machine, consider the availability and proximity of the required power supply circuit. If an existing circuit does not meet the requirements for this machine, a new circuit must be installed. To minimize the risk of electrocution, fire, or equipment damage, installation work and electrical wiring must be done by an electrician or qualified service personnel in accordance with all applicable codes and standards.

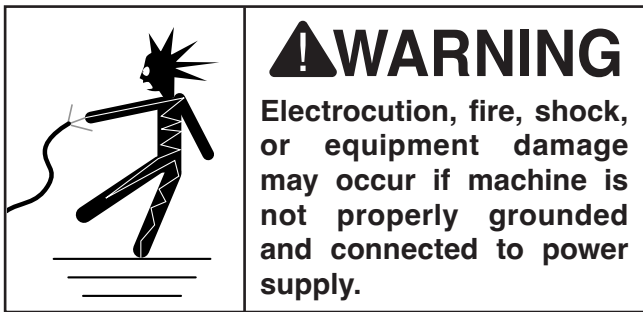

Full-Load Current Rating

The full-load current rating is the amperage a machine draws at 100% of the rated output power. On machines with multiple motors, this is the amperage drawn by the largest motor or sum of all motors and electrical devices that might operate at one time during normal operations.

Full-Load Current Rating at 220V 15.23A

The full-load current is not the maximum amount of amps that the machine will draw. If the machine is overloaded, it will draw additional amps beyond the full-load rating.

If the machine is overloaded for a sufficient length of time, damage, overheating, or fire may result—especially if connected to an undersized circuit. To reduce the risk of these hazards, avoid overloading the machine during operation and make sure it is connected to a power supply circuit that meets the specified circuit requirements.

Circuit Requirements for 220V

This machine is prewired to operate on a power supply circuit that has a verified ground and meets the following requirements:

Nominal Voltage 208V, 220V, 230V, 240V
Cycle.....60 Hz
Phase..... Single-Phase
Power Supply Circuit 20 Amps
Plug/Receptacle NEMA 6-20
Cord “S”-Type, 3-Wire, 14 AWG, 300 VAC

A power supply circuit includes all electrical equipment between the breaker box or fuse panel in the building and the machine. The power supply circuit used for this machine must be sized to safely handle the full-load current drawn from the machine for an extended period of time. (If this machine is connected to a circuit protected by fuses, use a time delay fuse marked D.)

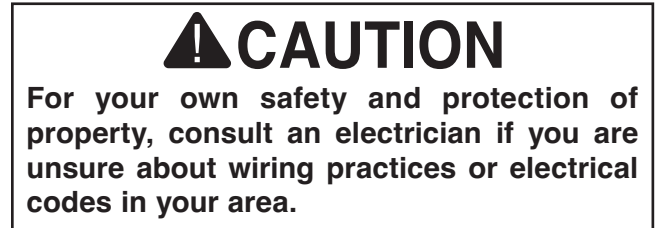

Note: *Circuit requirements in this manual apply to a dedicated circuit—where only one machine will be running on the circuit at a time. If machine will be connected to a shared circuit where multiple machines may be running at the same time, consult an electrician or qualified service personnel to ensure circuit is properly sized for safe operation.*



grizzly.com®
TOOL WEBSITE

Buy Direct and Save with Grizzly® – Trusted, Proven and a Great Value!
~Since 1983~

*Visit Our Website Today For
Current Specials!*

**ORDER
24 HOURS A DAY!
1-800-523-4777**



Grizzly **Industrial, Inc.**®

MODEL G0592 **10" X 18" METAL-CUTTING** **BANDSAW** **OWNER'S MANUAL** *(For models manufactured since 01/23)*



COPYRIGHT © MAY, 2006 BY GRIZZLY INDUSTRIAL, INC., REVISED DECEMBER, 2022 (CS)
**WARNING: NO PORTION OF THIS MANUAL MAY BE REPRODUCED IN ANY SHAPE
OR FORM WITHOUT THE WRITTEN APPROVAL OF GRIZZLY INDUSTRIAL, INC.**
#PC7789 PRINTED IN TAIWAN

V2.12.22

*****Keep for Future Reference*****

 **WARNING!**

This manual provides critical safety instructions on the proper setup, operation, maintenance, and service of this machine/tool. Save this document, refer to it often, and use it to instruct other operators.

Failure to read, understand and follow the instructions in this manual may result in fire or serious personal injury—including amputation, electrocution, or death.

The owner of this machine/tool is solely responsible for its safe use. This responsibility includes but is not limited to proper installation in a safe environment, personnel training and usage authorization, proper inspection and maintenance, manual availability and comprehension, application of safety devices, cutting/sanding/grinding tool integrity, and the usage of personal protective equipment.

The manufacturer will not be held liable for injury or property damage from negligence, improper training, machine modifications or misuse.

 **WARNING!**

Some dust created by power sanding, sawing, grinding, drilling, and other construction activities contains chemicals known to the State of California to cause cancer, birth defects or other reproductive harm. Some examples of these chemicals are:

- **Lead from lead-based paints.**
- **Crystalline silica from bricks, cement and other masonry products.**
- **Arsenic and chromium from chemically-treated lumber.**

Your risk from these exposures varies, depending on how often you do this type of work. To reduce your exposure to these chemicals: Work in a well ventilated area, and work with approved safety equipment, such as those dust masks that are specially designed to filter out microscopic particles.

Table of Contents

INTRODUCTION	2	SECTION 5: ACCESSORIES	40
Contact Info.....	2	SECTION 6: MAINTENANCE	42
Manual Accuracy	2	Schedule	42
Identification.....	3	Cleaning & Protecting	42
Controls & Components.....	4	Lubrication	42
Machine Data Sheet	7	Coolant System Maintenance.....	45
SECTION 1: SAFETY	9	Storing Machine	47
Safety Instructions for Machinery	9	SECTION 7: SERVICE	49
Additional Safety for Horizontal Metal Bandsaws	11	Troubleshooting	49
SECTION 2: POWER SUPPLY	12	Adjusting Blade Guide Bearings.....	52
SECTION 3: SETUP	14	Adjusting Blade Tracking	54
Needed for Setup.....	14	Squaring Blade to Table	55
Unpacking	14	Adjusting Blade Brush	56
Inventory	14	Adjusting Downfeed Stop Bolt	56
Site Considerations.....	16	Adjusting Angle Stops.....	57
Lifting & Placing	17	Tensioning/Replacing V-Belt.....	59
Anchoring to Floor	17	SECTION 8: WIRING	60
Assembly	18	Wiring Safety Instructions	60
Power Connection.....	19	Wiring Diagram	61
Test Run	20	Electrical Component Photos	62
Recommended Adjustments.....	21	SECTION 9: PARTS	64
SECTION 4: OPERATIONS	22	Base.....	64
Operation Overview	22	Swivel Base	66
Operation Tips	23	Vise	68
Workpiece Inspection.....	23	Headstock.....	70
Using Vise.....	24	Blade Tension & Motor	71
Selecting Blades	25	Blade Guides	73
Changing Blade	27	Electrical	75
Tensioning Blade	29	Labels & Cosmetics	76
Blade Breakage	30	WARRANTY & RETURNS	77
Blade Care & Break-In.....	31		
Changing Blade Speed.....	31		
Blade Speed Chart	32		
Chip Inspection Chart	33		
Setting Blade Feed Rate.....	34		
Adjusting Cutting Angle	34		
Adjusting Upper Blade Guide	36		
Adjusting Work Stop	36		
Using Coolant System	37		

INTRODUCTION

Contact Info

We stand behind our machines! If you have questions or need help, contact us with the information below. Before contacting, make sure you get the **serial number** and **manufacture date** from the machine ID label. This will help us help you faster.

Grizzly Technical Support
1815 W. Battlefield
Springfield, MO 65807
Phone: (570) 546-9663
Email: techsupport@grizzly.com

We want your feedback on this manual. What did you like about it? Where could it be improved? Please take a few minutes to give us feedback.

Grizzly Documentation Manager
P.O. Box 2069
Bellingham, WA 98227-2069
Email: manuals@grizzly.com

Manual Accuracy

We are proud to provide a high-quality owner's manual with your new machine!

We made every effort to be exact with the instructions, specifications, drawings, and photographs in this manual. Sometimes we make mistakes, but our policy of continuous improvement also means that **sometimes the machine you receive is slightly different than shown in the manual.**

If you find this to be the case, and the difference between the manual and machine leaves you confused or unsure about something, check our website for an updated version. We post current manuals and manual updates for free on our website at www.grizzly.com.

Alternatively, you can call our Technical Support for help. Before calling, make sure you write down the **manufacture date** and **serial number** from the machine ID label (see below). This information is required for us to provide proper tech support, and it helps us determine if updated documentation is available for your machine.

Grizzly Industrial MODEL GXXXX
MACHINE NAME

SPECIFICATIONS	WARNING!
Motor: _____	To reduce risk of serious injury when using this machine:
Specification: _____	1. Read manual before operation.
Specification: _____	2. Wear safety glasses and respirator.
Specification: _____	3. Make sure machine is properly adjusted/setup and
Weight: _____	power is connected to grounded circuit before starting.
Date: _____	4. Make sure the motor has stopped and disconnect
_____	power before adjustments, maintenance, or service.
_____	5. DO NOT expose to rain or dampness.
_____	6. DO NOT modify this machine in any way.
_____	7. _____
_____	8. _____
_____	9. _____
Manufactured for Grizzly in Taiwan	10. Maintain machine carefully to prevent accidents.



Identification

Become familiar with the names and locations of the controls and features shown below to better understand the instructions in this manual.

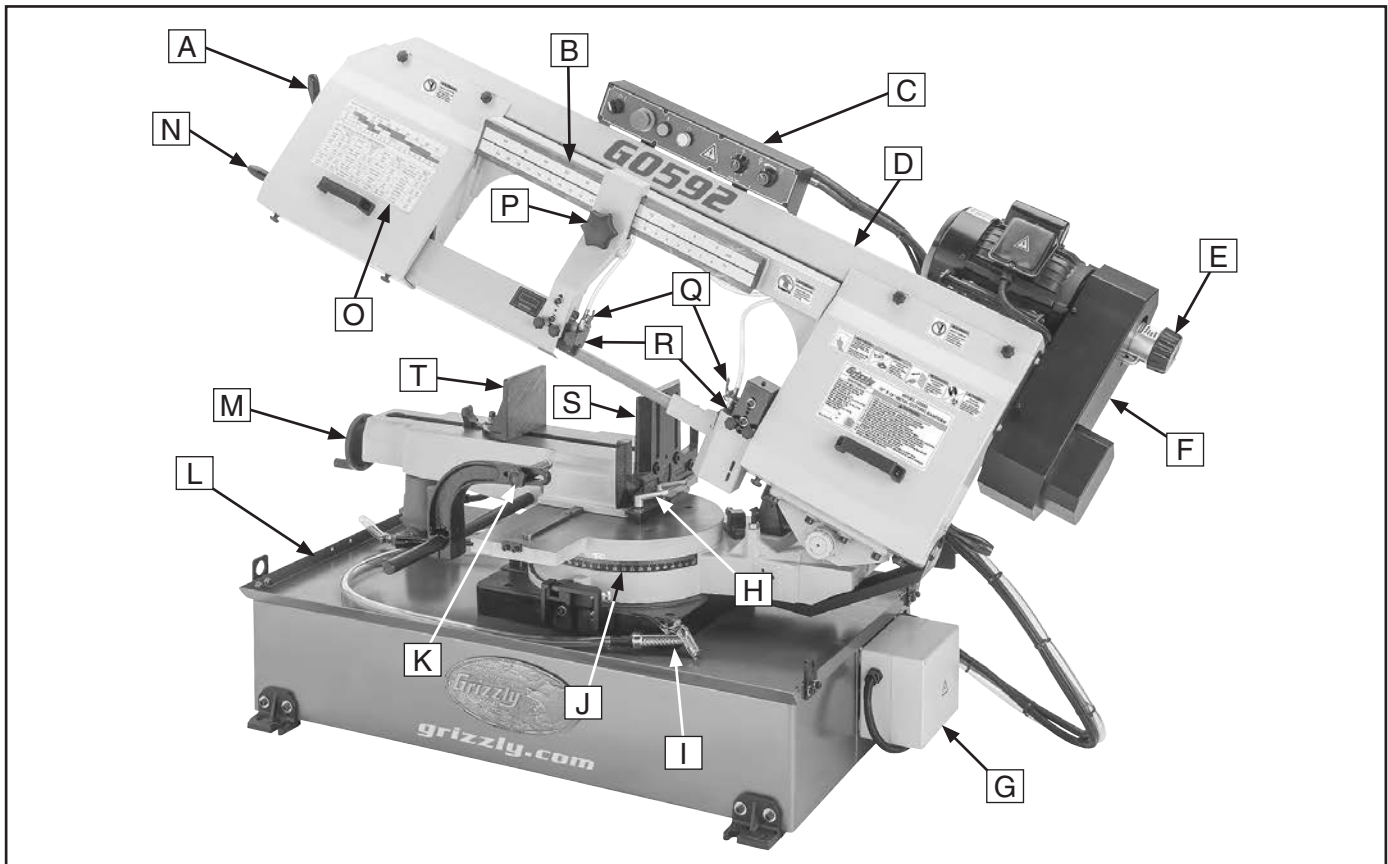

- | | |
|------------------------------|----------------------------------|
| A. Blade Tension Handle | K. Work Stop |
| B. Blade Guide Scale | L. Coolant Pan |
| C. Control Panel | M. Vise Handwheel |
| D. Headstock | N. Headstock Handle |
| E. Speed Adjustment Knob | O. Speed & Blade Selection Chart |
| F. Belt Cover | P. Blade Guide Knob |
| G. Electrical Box | Q. Coolant Valve Controls |
| H. Vise Lock Handle (1 of 2) | R. Blade Guides |
| I. Spray Gun | S. Fixed Vise Jaw |
| J. Rotational Degree Scale | T. Movable Vise Jaw |

⚠️ WARNING

For Your Own Safety Read Instruction Manual Before Operating Saw

- a) Wear eye protection and respirator.
- b) Do not remove jammed cutoff pieces until blade has stopped.
- c) Maintain proper adjustment of blade tension, blade guides, and thrust bearings.
- d) Adjust upper guide to just clear workpiece.
- e) Properly support and secure workpiece with table, vise, or some type of support fixture.
Never hold workpiece with hands during cut.



Controls & Components

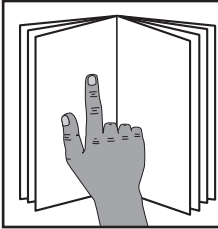

!WARNING

To reduce your risk of serious injury, read this entire manual **BEFORE** using machine.

!WARNING

Like all machinery there is potential danger when operating this machine. Accidents are frequently caused by lack of familiarity or failure to pay attention. Use this machine with respect and caution to decrease the risk of operator injury. If normal safety precautions are overlooked or ignored, serious personal injury may occur.

!CAUTION

No list of safety guidelines can be complete. Every shop environment is different. Always consider safety first, as it applies to your individual working conditions. Use this and other machinery with caution and respect. Failure to do so could result in serious personal injury, damage to equipment, or poor work results.

Refer to the following figures and descriptions to become familiar with the basic controls and components of this machine. Understanding these items and how they work will help you understand the rest of the manual and minimize your risk of injury when operating this machine.

Headstock

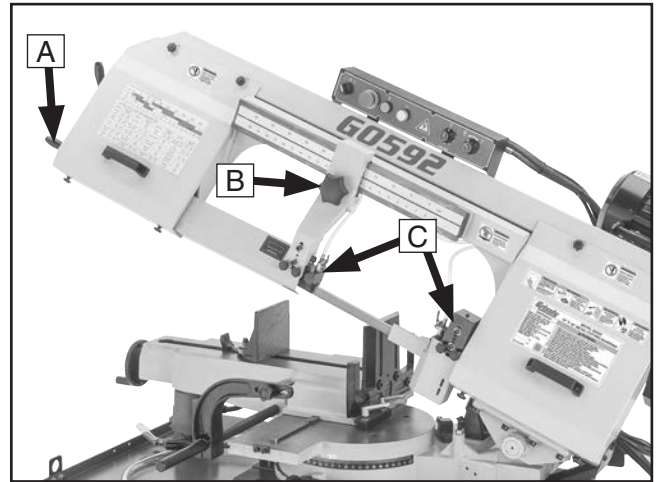

Figure 1. Front headstock components.

- A. **Headstock Handle:** Adjusts headstock angle when swivel lock components are released.
- B. **Blade Guide Knob:** Loosens to adjust upper blade guide position; tightens to secure.
- C. **Blade Guides:** Support blade. Adjust upper blade guide as close to workpiece as possible to prevent blade from twisting.

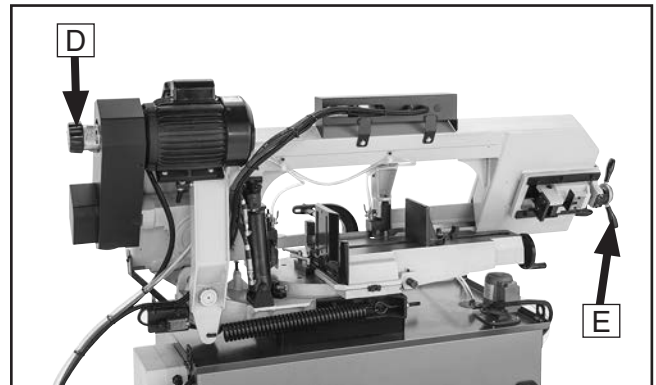

Figure 2. Rear headstock components.

- D. **Speed Adjustment Knob:** Adjusts blade speed from 98–394 FPM. Rotate knob clockwise to decrease speed or counterclockwise to increase speed.

IMPORTANT: To avoid damaging machine, **ONLY** change blade speed while main motor is running.

- E. **Blade Tension Handle:** Increases or decreases blade tension.



Swivel

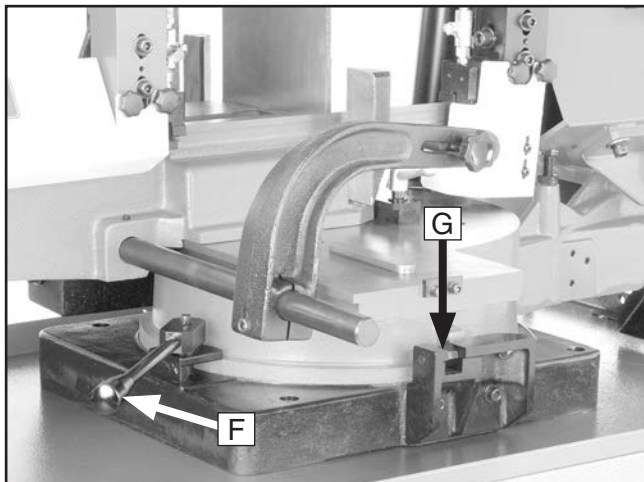

Figure 3. Swivel components.

- F. Swivel Lock Lever:** Loosens to adjust headstock angle; tightens to secure angle.
- G. Swivel Stop:** Secures headstock angle at 0°.

Coolant

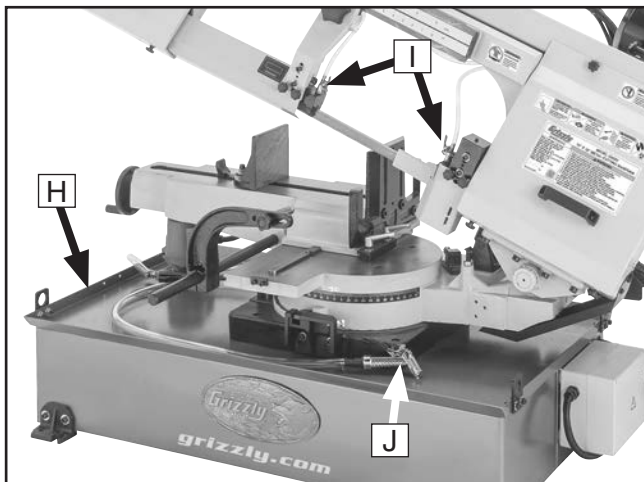

Figure 4. Coolant components.

- H. Coolant Pan:** Catches coolant and metal chips during cutting operations.
- I. Coolant Valves:** Control flow of coolant onto blade.
- J. Spray Gun:** Rinses metal chips into coolant pan or drain filter.

Vise Table

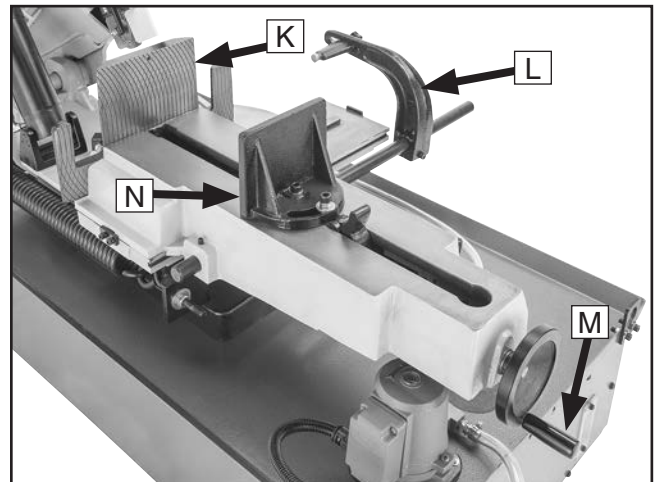

Figure 5. Vise table components.

- K. Fixed Vise Jaw:** Helps hold workpiece during cutting operations.
- L. Work Stop Assembly:** Adjusts for repetitive cutting operations.
- M. Vise Handwheel:** Closes and opens vise to clamp workpiece.
- N. Movable Vise Jaw:** Secures workpiece against fixed vise jaw. Features quick-adjustment latch that allows jaw width to be adjusted quickly.

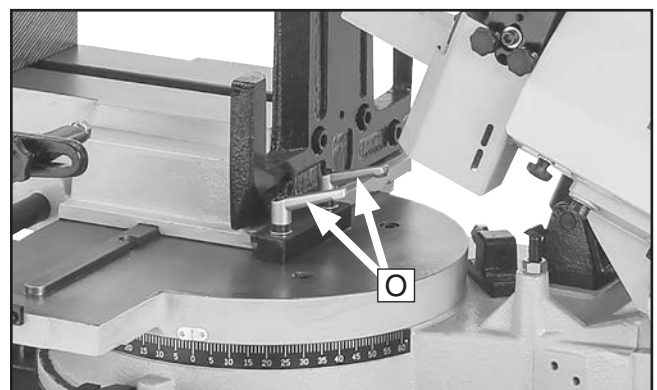

Figure 6. Location of vise lock handles.

- O. Vise Lock Handles:** Loosen to adjust vise base position in relation to blade; tighten to secure vise base position.



Control Panel

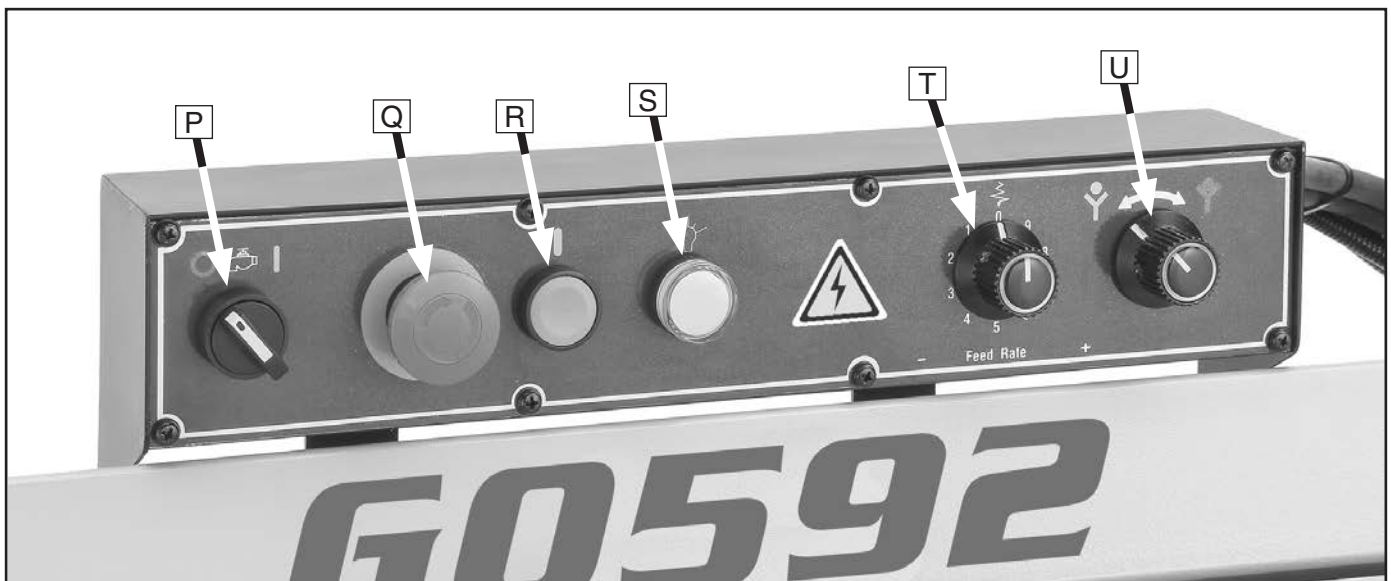

Figure 7. Control panel components.

- P. Coolant Pump Switch:** Turns coolant pump **ON**.
- Q. Emergency Stop/Off Button:** Interrupts power to system and turns motor **OFF**. Twist button until it pops out to re-energize system. Also works as standard Off button.
- Note:** Bandsaw has automatic shut-off (limit switch) that turns machine **OFF** at completion of cutting arc.
- R. Start Button:** Turns main motor **ON** and activates moving parts.
- S. Power Light:** When lit, indicates system is energized and machine is ready to operate.
- T. Feed Rate Dial:** Fine tunes rate at which blade feeds into workpiece by controlling hydraulic valve. Range is from 0 (slowest) to 9 (fastest).
- U. Feed Control Dial:** Turning dial left lowers headstock at feed rate you have set. Turning dial fully right locks headstock in position.





MACHINE DATA SHEET

Customer Service #: (570) 546-9663 · To Order Call: (800) 523-4777 · Fax #: (800) 438-5901

MODEL G0592 10" X 18" METAL-CUTTING BANDSAW

Product Dimensions:

Weight..... 858 lbs.
 Width (side-to-side) x Depth (front-to-back) x Height..... 72-1/2 x 32 x 58 in.
 Footprint (Length x Width)..... 28-1/2 x 45 in.

Shipping Dimensions:

Type..... Wood Slat Crate
 Content..... Machine
 Weight..... 967 lbs.
 Length x Width x Height..... 79 x 36 x 49 in.
 Must Ship Upright..... Yes

Electrical:

Power Requirement..... 220V, Single-Phase, 60 Hz
 Full-Load Current Rating..... 15.45A
 Minimum Circuit Size..... 20A
 Connection Type..... Cord & Plug
 Power Cord Included..... Yes
 Power Cord Length..... 72 in.
 Power Cord Gauge..... 14 AWG
 Plug Included..... No
 Recommended Plug Type..... 6-20
 Switch Type..... Control Panel w/Magnetic Switch Protection

Motors:

Main

Horsepower..... 2 HP
 Phase..... Single-Phase
 Amps..... 15A
 Speed..... 1725 RPM
 Type..... TEFC Capacitor-Start Induction
 Power Transfer Belt
 Bearings..... Shielded & Permanently Lubricated
 Centrifugal Switch/Contacts Type..... External

Coolant Pump

Horsepower..... 1/8 HP
 Phase..... Single-Phase
 Amps..... 0.45A
 Speed..... 3400
 Type..... TEFC Induction
 Power Transfer Direct
 Bearings..... Shielded & Permanently Lubricated



Main Specifications:

Operation Info

Blade Speeds.....	98 - 394 FPM
Std. Blade Length.....	132 in.
Blade Length Range.....	1 in.
Head Swivel.....	Right 45, Left 60 deg.

Cutting Capacities

Angle Cuts.....	Right 45, Left 60 deg.
Vise Jaw Depth.....	7-1/2 in.
Vise Jaw Height.....	5 in.
Max. Capacity Rectangular Height at 90 Deg.....	9-1/2 in.
Max. Capacity Rectangular Width at 90 Deg.....	18 in.
Max. Capacity Round at 90 Deg.....	10 in.
Max. Capacity Rectangular Height at 30 Deg.....	10 in.
Max. Capacity Rectangular Width at 30 Deg.....	14 in.
Max. Capacity Round at 30 Deg.....	10 in.
Max. Capacity Rectangular Height at 45 Deg.....	10 in.
Max. Capacity Rectangular Width at 45 Deg.....	11 in.
Max. Capacity Round at 45 Deg.....	10 in.
Max. Capacity Rectangular Height at 60 Deg.....	5 in.
Max. Capacity Rectangular Width at 60 Deg.....	8 in.
Max. Capacity Round at 60 Deg.....	8 in.

Construction

Table.....	Cast Iron
Upper Wheel.....	Cast Iron
Lower Wheel.....	Cast Iron
Body.....	Formed Steel
Base.....	Cast Iron
Stand.....	Formed Steel
Wheel Cover.....	Pre-formed Steel
Paint Type/Finish.....	Epoxy

Other

Blade Guides Upper.....	Ball Bearing
Blade Guides Lower.....	Ball Bearing
Coolant Capacity.....	4 gallons

Table Info

Floor To Cutting Area Height.....	20 in.
-----------------------------------	--------

Other Specifications:

Country of Origin	Taiwan
Warranty	1 Year
Approximate Assembly & Setup Time	1-1/2 Hours
Serial Number Location	ID Label

Features:

- Coolant Pump
- Blade Speed Chart
- Variable Speed
- Quick-Release Vise
- Adjustable Hydraulic Downfeed
- Automatic Shut-off



SECTION 1: SAFETY

For Your Own Safety, Read Instruction Manual Before Operating This Machine

The purpose of safety symbols is to attract your attention to possible hazardous conditions. This manual uses a series of symbols and signal words intended to convey the level of importance of the safety messages. The progression of symbols is described below. Remember that safety messages by themselves do not eliminate danger and are not a substitute for proper accident prevention measures. Always use common sense and good judgment.

⚠ DANGER Indicates an imminently hazardous situation which, if not avoided, **WILL** result in death or serious injury.

⚠ WARNING Indicates a potentially hazardous situation which, if not avoided, **COULD** result in death or serious injury.

⚠ CAUTION Indicates a potentially hazardous situation which, if not avoided, **MAY** result in minor or moderate injury. It may also be used to alert against unsafe practices.

NOTICE Alerts the user to useful information about proper operation of the machine to avoid machine damage.

Safety Instructions for Machinery

⚠ WARNING

OWNER'S MANUAL. Read and understand this owner's manual **BEFORE** using machine.

TRAINED OPERATORS ONLY. Untrained operators have a higher risk of being hurt or killed. Only allow trained/supervised people to use this machine. When machine is not being used, disconnect power, remove switch keys, or lock-out machine to prevent unauthorized use—especially around children. Make your workshop kid proof!

DANGEROUS ENVIRONMENTS. Do not use machinery in areas that are wet, cluttered, or have poor lighting. Operating machinery in these areas greatly increases the risk of accidents and injury.

MENTAL ALERTNESS REQUIRED. Full mental alertness is required for safe operation of machinery. Never operate under the influence of drugs or alcohol, when tired, or when distracted.

ELECTRICAL EQUIPMENT INJURY RISKS. You can be shocked, burned, or killed by touching live electrical components or improperly grounded machinery. To reduce this risk, only allow qualified service personnel to do electrical installation or repair work, and always disconnect power before accessing or exposing electrical equipment.

DISCONNECT POWER FIRST. Always disconnect machine from power supply **BEFORE** making adjustments, changing tooling, or servicing machine. This prevents an injury risk from unintended startup or contact with live electrical components.

EYE PROTECTION. Always wear ANSI-approved safety glasses or a face shield when operating or observing machinery to reduce the risk of eye injury or blindness from flying particles. Everyday eyeglasses are **NOT** approved safety glasses.



WARNING

WEARING PROPER APPAREL. Do not wear clothing, apparel or jewelry that can become entangled in moving parts. Always tie back or cover long hair. Wear non-slip footwear to reduce risk of slipping and losing control or accidentally contacting cutting tool or moving parts.

HAZARDOUS DUST. Dust created by machinery operations may cause cancer, birth defects, or long-term respiratory damage. Be aware of dust hazards associated with each workpiece material. Always wear a NIOSH-approved respirator to reduce your risk.

HEARING PROTECTION. Always wear hearing protection when operating or observing loud machinery. Extended exposure to this noise without hearing protection can cause permanent hearing loss.

REMOVE ADJUSTING TOOLS. Tools left on machinery can become dangerous projectiles upon startup. Never leave chuck keys, wrenches, or any other tools on machine. Always verify removal before starting!

USE CORRECT TOOL FOR THE JOB. Only use this tool for its intended purpose—do not force it or an attachment to do a job for which it was not designed. Never make unapproved modifications—modifying tool or using it differently than intended may result in malfunction or mechanical failure that can lead to personal injury or death!

AWKWARD POSITIONS. Keep proper footing and balance at all times when operating machine. Do not overreach! Avoid awkward hand positions that make workpiece control difficult or increase the risk of accidental injury.

CHILDREN & BYSTANDERS. Keep children and bystanders at a safe distance from the work area. Stop using machine if they become a distraction.

GUARDS & COVERS. Guards and covers reduce accidental contact with moving parts or flying debris. Make sure they are properly installed, undamaged, and working correctly **BEFORE** operating machine.

FORCING MACHINERY. Do not force machine. It will do the job safer and better at the rate for which it was designed.

NEVER STAND ON MACHINE. Serious injury may occur if machine is tipped or if the cutting tool is unintentionally contacted.

STABLE MACHINE. Unexpected movement during operation greatly increases risk of injury or loss of control. Before starting, verify machine is stable and mobile base (if used) is locked.

USE RECOMMENDED ACCESSORIES. Consult this owner's manual or the manufacturer for recommended accessories. Using improper accessories will increase the risk of serious injury.

UNATTENDED OPERATION. To reduce the risk of accidental injury, turn machine **OFF** and ensure all moving parts completely stop before walking away. Never leave machine running while unattended.

MAINTAIN WITH CARE. Follow all maintenance instructions and lubrication schedules to keep machine in good working condition. A machine that is improperly maintained could malfunction, leading to serious personal injury or death.

DAMAGED PARTS. Regularly inspect machine for damaged, loose, or mis-adjusted parts—or any condition that could affect safe operation. Immediately repair/replace **BEFORE** operating machine. For your own safety, **DO NOT** operate machine with damaged parts!

MAINTAIN POWER CORDS. When disconnecting cord-connected machines from power, grab and pull the plug—**NOT** the cord. Pulling the cord may damage the wires inside. Do not handle cord/plug with wet hands. Avoid cord damage by keeping it away from heated surfaces, high traffic areas, harsh chemicals, and wet/damp locations.

EXPERIENCING DIFFICULTIES. If at any time you experience difficulties performing the intended operation, stop using the machine! Contact our Technical Support at (570) 546-9663.



Additional Safety for Horizontal Metal Bandsaws

WARNING

Serious injury or death can occur from getting fingers, hair, or clothing entangled in rotating or moving parts or making direct contact with the moving blade. To minimize risk of injury, anyone operating this machine **MUST** completely heed hazards and warnings below.

BLADE CONDITION. Do not operate with dull, cracked, or badly worn blade. Inspect blades for cracks and missing teeth before each use.

HAND PLACEMENT. Never position hands or fingers in line with the cut or under bandsaw headstock while lowering or operating. Hands could be cut or crushed.

BLADE GUARD POSITION. Adjust blade guard as close to workpiece as possible before cutting to minimize operator exposure to unused portion of blade.

ENTANGLEMENT HAZARDS. Do not operate this saw without blade guard in place. Loose clothing, jewelry, long hair and work gloves can be drawn into working parts.

BLADE REPLACEMENT. When replacing blades, disconnect the machine from power, wear gloves to protect hands and safety glasses to protect eyes.

HOT SURFACES. Contact with hot surfaces from machine components, ejections of hot chips, swarf, and the workpiece itself can cause burns.

WORKPIECE HANDLING. Always properly support workpiece with table, vise, or some type of support fixture. Always secure workpiece in vise before cutting. Never hold the workpiece with your hands during a cut.

UNSTABLE WORKPIECES. Avoid cutting workpieces that cannot be properly supported or clamped in a vise or jig, because they can unexpectedly move while cutting and draw the operator's hands into the blade causing serious personal injury. Examples are chains, cables, round or oblong-shaped workpieces, and those with internal or built-in moving or rotating parts, etc.

FIRE HAZARD. Use **EXTREME CAUTION** if cutting magnesium. Using the wrong cutting fluid could lead to chip fire and possible explosion.

CUTTING FLUID SAFETY. Cutting fluids are poisonous. Always follow manufacturer's cutting-fluid safety instructions. Pay particular attention to contact, contamination, inhalation, storage and disposal warnings. Spilled cutting fluid invites slipping hazards.



SECTION 2: POWER SUPPLY

Availability

Before installing the machine, consider the availability and proximity of the required power supply circuit. If an existing circuit does not meet the requirements for this machine, a new circuit must be installed. To minimize the risk of electrocution, fire, or equipment damage, installation work and electrical wiring must be done by an electrician or qualified service personnel in accordance with all applicable codes and standards.

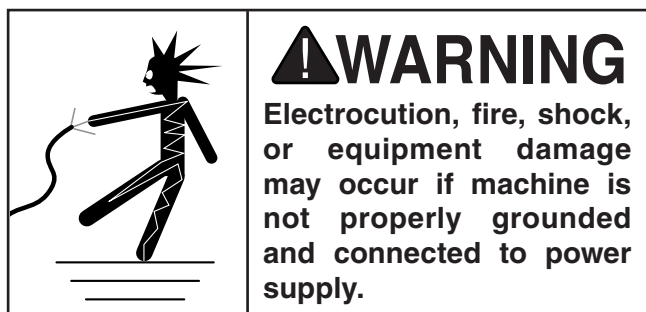

Full-Load Current Rating

The full-load current rating is the amperage a machine draws at 100% of the rated output power. On machines with multiple motors, this is the amperage drawn by the largest motor or sum of all motors and electrical devices that might operate at one time during normal operations.

Full-Load Current Rating at 220V 15 Amps

The full-load current is not the maximum amount of amps that the machine will draw. If the machine is overloaded, it will draw additional amps beyond the full-load rating.

If the machine is overloaded for a sufficient length of time, damage, overheating, or fire may result—especially if connected to an undersized circuit. To reduce the risk of these hazards, avoid overloading the machine during operation and make sure it is connected to a power supply circuit that meets the specified circuit requirements.

Circuit Requirements for 220V

This machine is prewired to operate on a power supply circuit that has a verified ground and meets the following requirements:

Nominal Voltage 208V, 220V, 230V, 240V
Cycle 60 Hz
Phase Single-Phase
Power Supply Circuit 20 Amps
Plug/Receptacle NEMA 6-20
Cord “S”-Type, 3-Wire, 14 AWG, 300 VAC

A power supply circuit includes all electrical equipment between the breaker box or fuse panel in the building and the machine. The power supply circuit used for this machine must be sized to safely handle the full-load current drawn from the machine for an extended period of time. (If this machine is connected to a circuit protected by fuses, use a time delay fuse marked D.)



Note: *Circuit requirements in this manual apply to a dedicated circuit—where only one machine will be running on the circuit at a time. If machine will be connected to a shared circuit where multiple machines may be running at the same time, consult an electrician or qualified service personnel to ensure circuit is properly sized for safe operation.*



Grounding Instructions

This machine **MUST** be grounded. In the event of certain malfunctions or breakdowns, grounding reduces the risk of electric shock by providing a path of least resistance for electric current.

The power cord and plug specified under “Circuit Requirements for 220V” on the previous page has an equipment-grounding wire and a grounding prong. The plug must only be inserted into a matching receptacle (outlet) that is properly installed and grounded in accordance with all local codes and ordinances (see figure below).

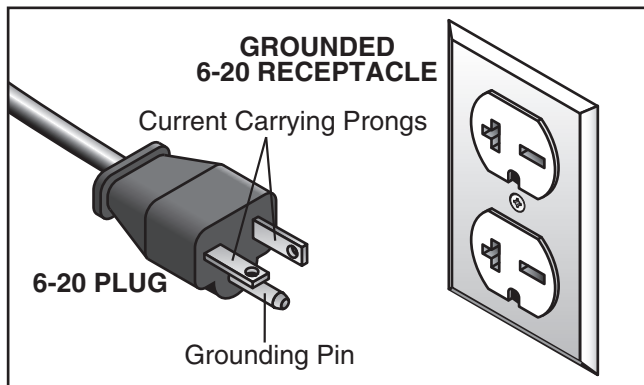

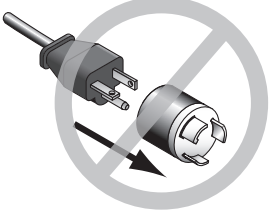

Figure 8. Typical 6-20 plug and receptacle.



CAUTION



No adapter should be used with plug. If plug does not fit available receptacle, or if machine must be reconnected for use on a different type of circuit, reconnection must be performed by an electrician or qualified service personnel, and it must comply with all local codes and ordinances.

WARNING

Serious injury could occur if you connect machine to power before completing setup process. DO NOT connect to power until instructed later in this manual.

Improper connection of the equipment-grounding wire can result in a risk of electric shock. The wire with green insulation (with or without yellow stripes) is the equipment-grounding wire. If repair or replacement of the power cord or plug is necessary, do not connect the equipment-grounding wire to a live (current carrying) terminal.

Check with a qualified electrician or service personnel if you do not understand these grounding requirements, or if you are in doubt about whether the tool is properly grounded. If you ever notice that a cord or plug is damaged or worn, disconnect it from power, and immediately replace it with a new one.

Extension Cords

We do not recommend using an extension cord with this machine. If you must use an extension cord, only use it if absolutely necessary and only on a temporary basis.

Extension cords cause voltage drop, which can damage electrical components and shorten motor life. Voltage drop increases as the extension cord size gets longer and the gauge size gets smaller (higher gauge numbers indicate smaller sizes).

Any extension cord used with this machine must be in good condition and contain a ground wire and matching plug/receptacle. Additionally, it must meet the following size requirements:

Minimum Gauge Size 14 AWG
Maximum Length (Shorter is Better).....50 ft.



SECTION 3: SETUP

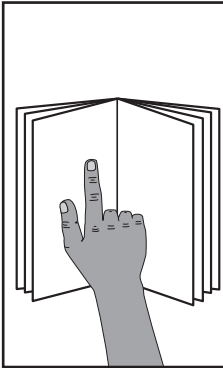

!WARNING

This machine presents serious injury hazards to untrained users. Read through this entire manual to become familiar with the controls and operations before starting the machine!

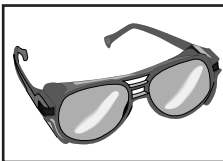

!WARNING

Wear safety glasses during the entire setup process!

Needed for Setup

The following items are needed, but not included, for the setup/assembly of this machine.

Description	Qty
• Disposable Rags	As Needed
• Cleaner/Degreaser	As Needed
• Safety Glasses (for each person).....	1 Pr.
• Disposable Gloves	As Needed
• Lifting Straps (Rated for 1100 lbs.)	4
• Lifting Equipment (Rated for 1100 lbs.)	1
• Open-End Wrenches 19mm	2
• Wrench or Socket 13mm	1
• Wrenches or Sockets 10mm	2
• Hex Wrenches 4, 6mm.....	1 Ea.
• NEMA Plug 6-20.....	1

Unpacking

This machine was carefully packaged for safe transport. When unpacking, separate all enclosed items from packaging materials and inspect them for shipping damage. ***If items are damaged, please call us immediately at (570) 546-9663.***

IMPORTANT: Save all packaging materials until you are completely satisfied with the machine and have resolved any issues between Grizzly or the shipping agent. *You MUST have the original packaging to file a freight claim. It is also extremely helpful if you need to return your machine later.*

Inventory

The following is a list of items shipped with your machine. Before beginning setup, lay these items out and inventory them.

If any non-proprietary parts are missing (e.g. a nut or a washer), we will gladly replace them; or for the sake of expediency, replacements can be obtained at your local hardware store.

Box 1 (Figure 9)	Qty
A. Splash Guard	1
B. Work Stop Rod	1
C. Work Stop Arm	1
D. Work Stop.....	1
E. Hex Bolts M12-1.75 x 50	4
F. Hex Nuts M12-1.75	4

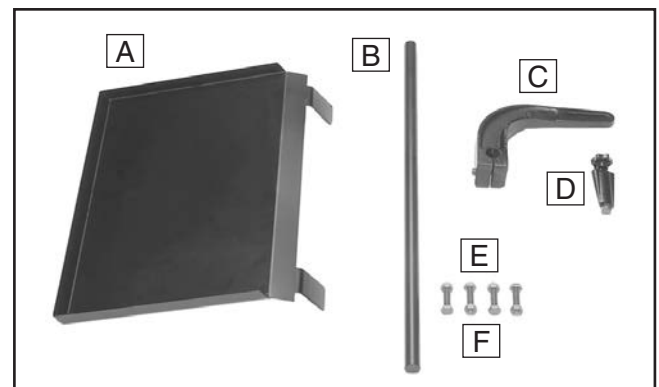

Figure 9. Loose inventory.

NOTICE

If you cannot find item on list, check around/inside machine and packaging materials. Often, these items get lost in packaging while unpacking or they are pre-installed.



Cleanup

The unpainted surfaces of your machine are coated with a heavy-duty rust preventative that prevents corrosion during shipment and storage. This rust preventative works extremely well, but it will take a little time to clean.

Be patient and do a thorough job cleaning your machine. The time you spend doing this now will give you a better appreciation for the proper care of your machine's unpainted surfaces.

There are many ways to remove this rust preventative, but the following steps work well in a wide variety of situations. Always follow the manufacturer's instructions with any cleaning product you use and make sure you work in a well-ventilated area to minimize exposure to toxic fumes.

Before cleaning, gather the following:

- Disposable rags
- Cleaner/degreaser (WD•40 works well)
- Safety glasses & disposable gloves
- Plastic paint scraper (optional)

Basic steps for removing rust preventative:

1. Put on safety glasses.
2. Coat the rust preventative with a liberal amount of cleaner/degreaser, then let it soak for 5–10 minutes.
3. Wipe off the surfaces. If your cleaner/degreaser is effective, the rust preventative will wipe off easily. If you have a plastic paint scraper, scrape off as much as you can first, then wipe off the rest with the rag.
4. Repeat **Steps 2–3** as necessary until clean, then coat all unpainted surfaces with a quality metal protectant to prevent rust.

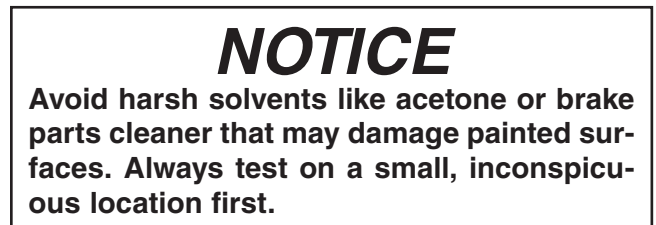
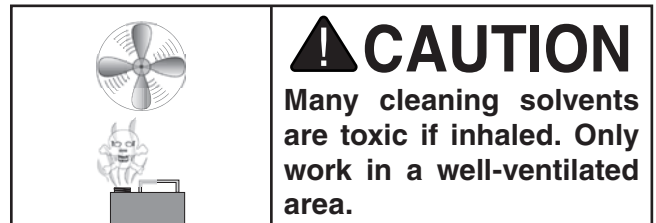
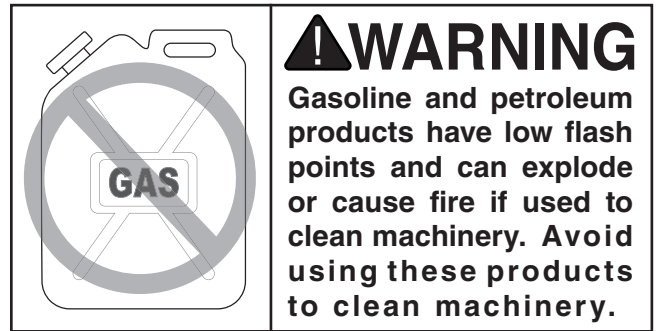

T23692—Orange Power Degreaser

A great product for removing the waxy shipping grease from the **non-painted** parts of the machine during clean up.



Figure 10. T23692 Orange Power Degreaser.



Site Considerations

Weight Load

Refer to the **Machine Data Sheet** for the weight of your machine. Make sure that the surface upon which the machine is placed will bear the weight of the machine, additional equipment that may be installed on the machine, and the heaviest workpiece that will be used. Additionally, consider the weight of the operator and any dynamic loading that may occur when operating the machine.

Space Allocation

Consider the largest size of workpiece that will be processed through this machine and provide enough space around the machine for adequate operator material handling or the installation of auxiliary equipment. With permanent installations, leave enough space around the machine to open or remove doors/covers as required by the maintenance and service described in this manual. **See below for required space allocation.**

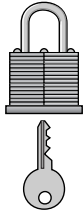
	<p>CAUTION</p> <p>Children or untrained people may be seriously injured by this machine. Only install in an access restricted location.</p>
---	--

Physical Environment

The physical environment where the machine is operated is important for safe operation and longevity of machine components. For best results, operate this machine in a dry environment that is free from excessive moisture, hazardous chemicals, airborne abrasives, or extreme conditions. Extreme conditions for this type of machinery are generally those where the ambient temperature range exceeds 41°–104°F; the relative humidity range exceeds 20%–95% (non-condensing); or the environment is subject to vibration, shocks, or bumps.

Electrical Installation

Place this machine near an existing power source. Make sure all power cords are protected from traffic, material handling, moisture, chemicals, or other hazards. Make sure to leave enough space around machine to disconnect power supply or apply a lockout/tagout device, if required.

Lighting

Lighting around the machine must be adequate enough that operations can be performed safely. Shadows, glare, or strobe effects that may distract or impede the operator must be eliminated.

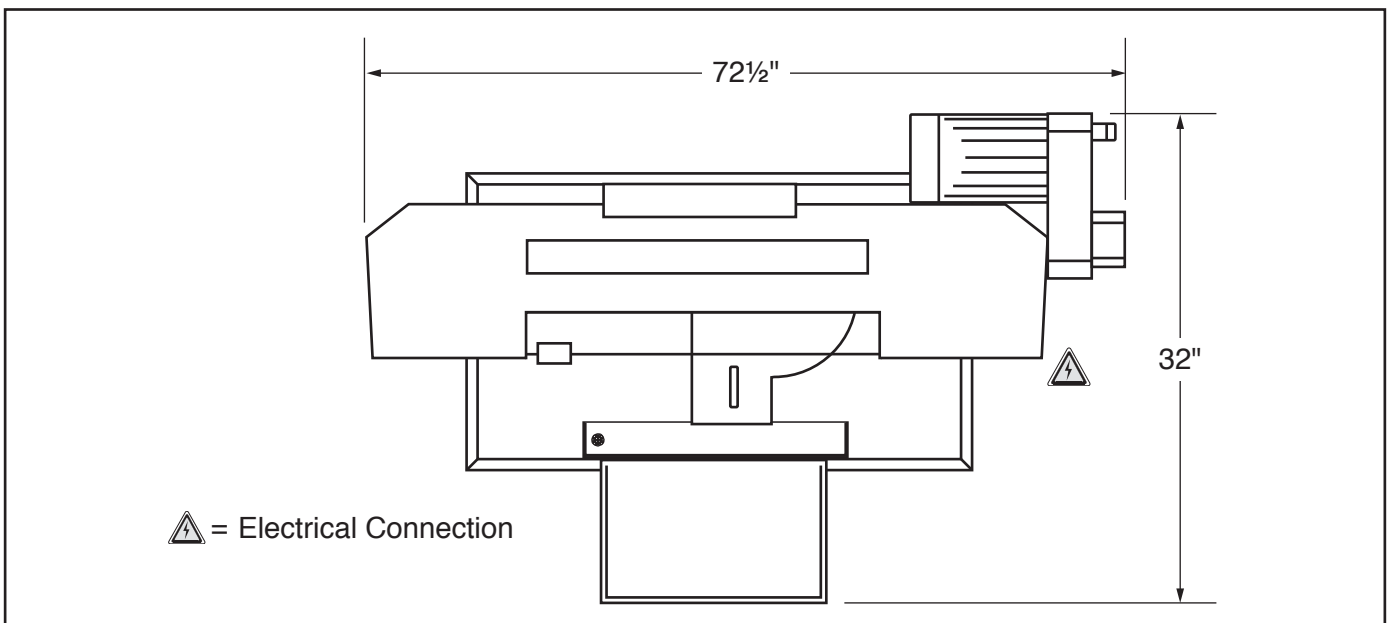
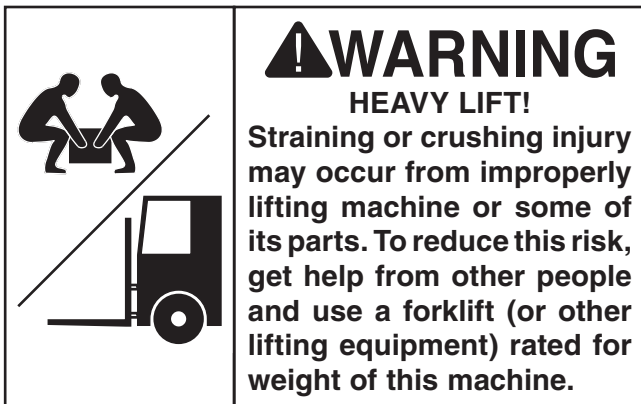

Figure 11. Minimum working clearances.



Lifting & Placing



The forklift and lifting straps must be rated for at least 1100 lbs.

To lift and place machine:

1. Remove shipping crate top and sides.
2. Attach lifting straps to lifting locations shown in **Figure 12**.

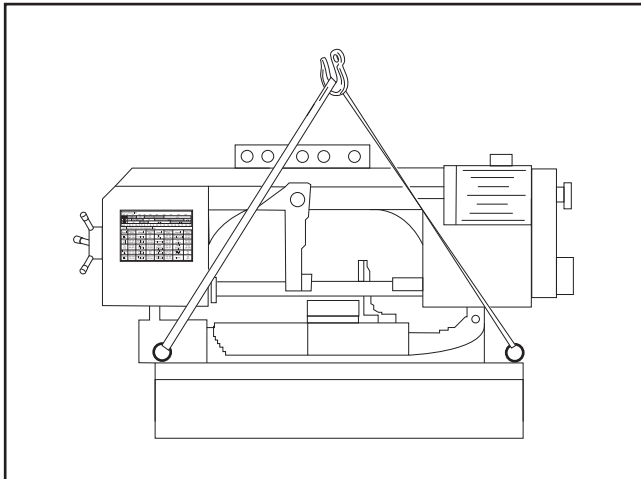

Figure 12. Example of lifting straps attached to lifting locations.

3. Lift machine off pallet and move it to suitable location.
 - If you wish to install leveling hex bolts and nuts included with machine, install these by referring to **Steps 1–2 of Assembly**.
 - If you wish to anchor machine to floor, refer to **Anchoring to Floor**.

Anchoring to Floor

Number of Mounting Holes 4
Diameter of Mounting Hardware..... 1/2"

Anchoring machinery to the floor prevents tipping or shifting and reduces vibration that may occur during operation, resulting in a machine that runs slightly quieter and feels more solid.

If the machine will be installed in a commercial or workplace setting, or if it is permanently connected (hardwired) to the power supply, local codes may require that it be anchored to the floor.

If not required by any local codes, fastening the machine to the floor is an optional step. If you choose not to do this with your machine, we recommend placing it on machine mounts, as these provide an easy method for leveling and they have vibration-absorbing pads.

Anchoring to Concrete Floors

Lag shield anchors with lag screws (see below) are a popular way to anchor machinery to a concrete floor, because the anchors sit flush with the floor surface, making it easy to unbolt and move the machine later, if needed. However, anytime local codes apply, you **MUST** follow the anchoring methodology specified by the code.

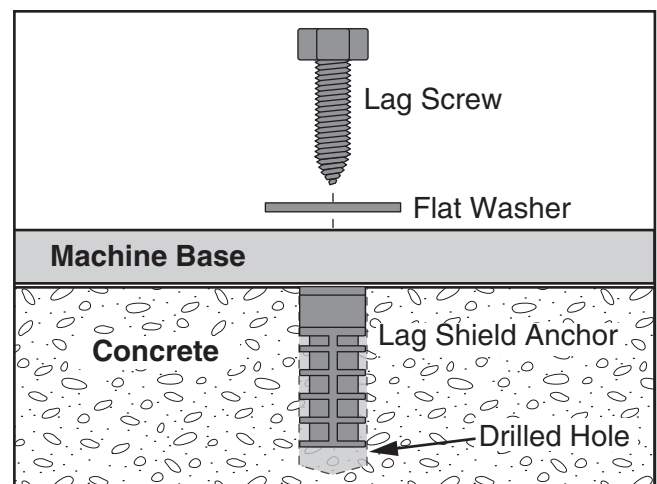

Figure 13. Popular method for anchoring machinery to a concrete floor.



Assembly

The machine must be fully assembled before it can be operated. Before beginning the assembly process, refer to **Needed for Setup** and gather all listed items. To ensure the assembly process goes smoothly, first clean any parts that are covered or coated in heavy-duty rust preventative (if applicable).

If you wish to install the leveling hex bolts and hex nuts included with the machine, begin assembly with **Step 1**. If you have anchored your machine to the floor, begin assembly with **Step 3**.

To assemble machine:

1. Thread (4) M12-1.75 hex nuts all the way onto (4) M12-1.75 x 50 hex bolts.
2. Thread each hex bolt into corner bracket of machine base (see **Figure 14**), then adjust hex bolts to level machine.

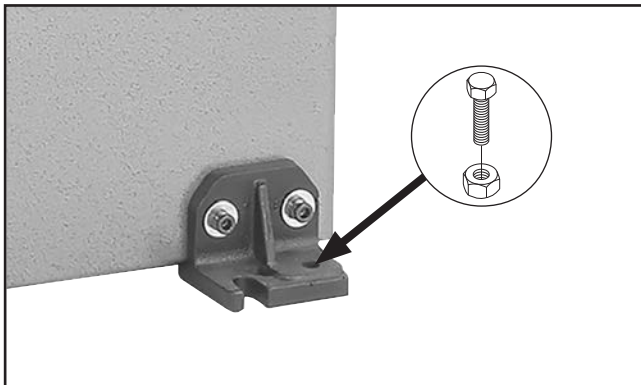

Figure 14. Location of corner bracket threaded hole.

3. Tighten hex nuts against corner brackets to secure setting.
4. Remove (2) hex nuts, (3) hex bolts, and washers shown in **Figure 15** to remove headstock shipping bracket.

Note: Keep bracket in case you need to move or ship machine. Bracket will keep headstock aligned during transit.

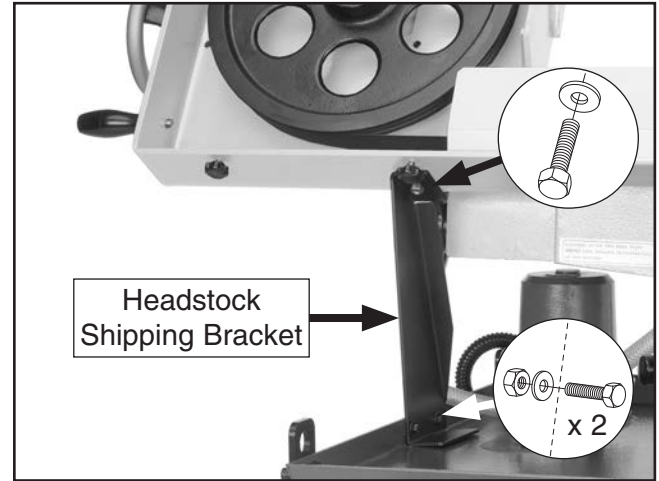

Figure 15. Location of headstock shipping bracket and fasteners (blade cover removed for clarity).

5. Slide work stop rod in hole in base of vise until it protrudes from hole on other side, then tighten (2) set screws shown in **Figure 17** to secure.

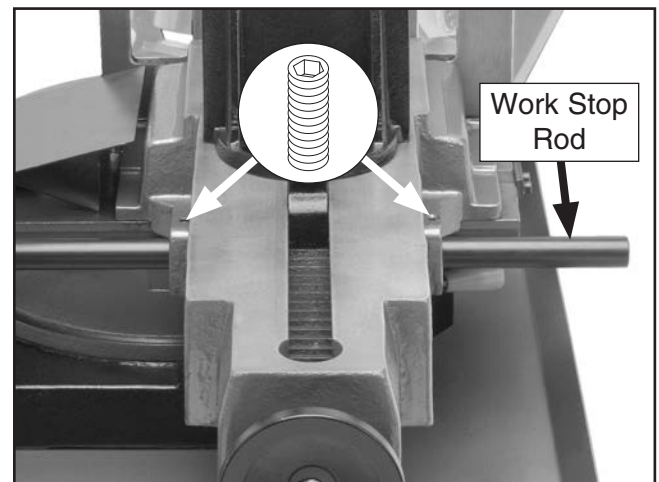

Figure 16. Work stop rod installed.

Note: Work stop rod can be installed on either side of vise base, depending upon cutting operation. It should be placed on same side where workpiece is being cut. Refer to **Adjusting Work Stop** on **Page 36** for additional details.



6. Slide work stop arm onto rod and tighten cap screw shown in **Figure 17** to secure.
7. Remove knob from work stop, insert work stop into arm, then secure with knob (see **Figure 17**).

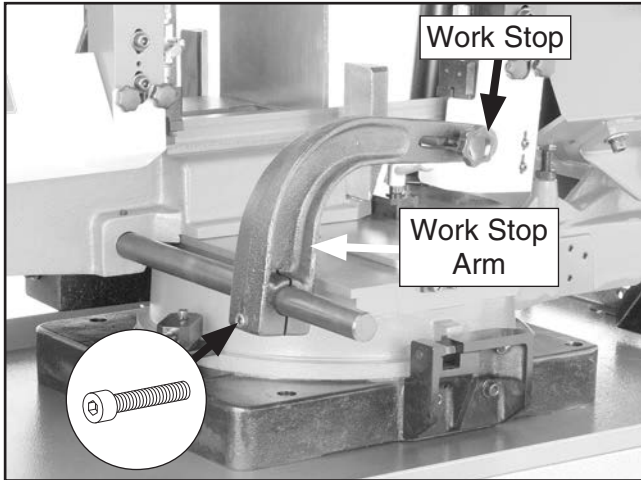

Figure 17. Work stop installed.

8. Fit splash guard over lip of base, as shown in **Figure 18**.

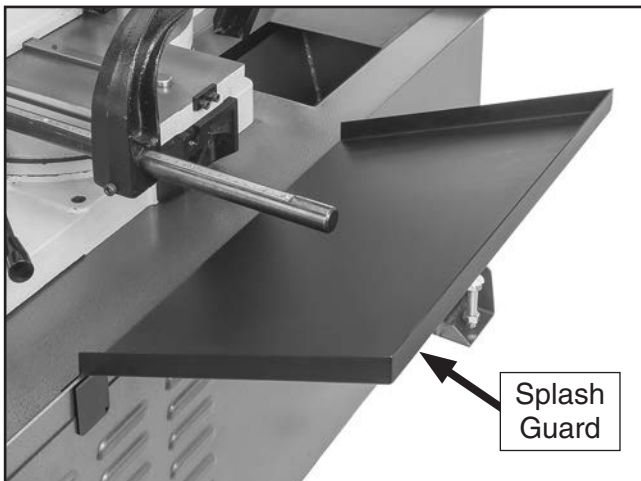
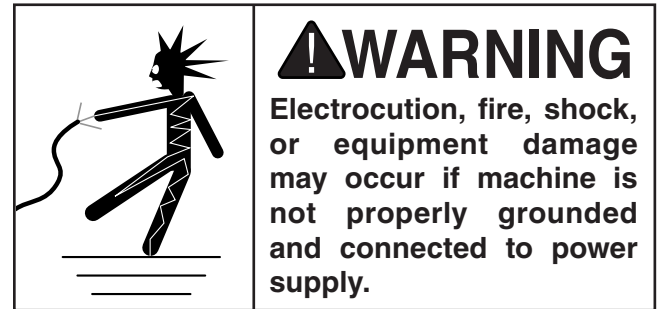

Figure 18. Example of splash guard installed on base lip.

Power Connection

Before the machine can be connected to the power source, an electrical circuit and connection device must be prepared per the **POWER SUPPLY** section in this manual, and all previous setup instructions in this manual must be complete to ensure that the machine has been assembled and installed properly.

Always make sure the Emergency Stop/Off button is pushed in before connecting power.



Connecting Plug to Power Cord

To connect a plug to the power cord, install a 6-20 plug on the end of the power cord per the plug manufacturer's instructions. If no instructions were included, use the wiring diagram on **Page 61**.



Test Run

Once assembly is complete, test run the machine to ensure it is properly connected to power and safety components are functioning correctly.

If you find an unusual problem during the test run, immediately stop the machine, disconnect it from power, and fix the problem **BEFORE** operating the machine again. The **Troubleshooting** table in the **SERVICE** section of this manual can help.

The test run consists of verifying the following: 1) the main motor runs correctly, 2) the Emergency Stop/Off button safety feature works correctly, 3) the downfeed limit switch and stop bolt work correctly, and 4) the coolant pump motor runs correctly.

⚠️ WARNING

Serious injury or death can result from using this machine BEFORE understanding its controls and related safety information. DO NOT operate, or allow others to operate, machine until the information is understood.

⚠️ WARNING

DO NOT start machine until all preceding setup instructions have been performed. Operating an improperly set up machine may result in malfunction or unexpected results that can lead to serious injury, death, or machine/property damage.

To test run machine:

1. Clear all setup tools away from machine.
2. Use headstock handle to raise headstock all the way up, then turn feed control dial all the way right (see **Figure 19**).
3. Turn feed rate dial to "1" (see **Figure 19**).
4. Press Emergency Stop/Off button (see **Figure 19**).

5. Connect machine to power by inserting power cord plug into matching receptacle; power light will illuminate (see **Figure 19**).

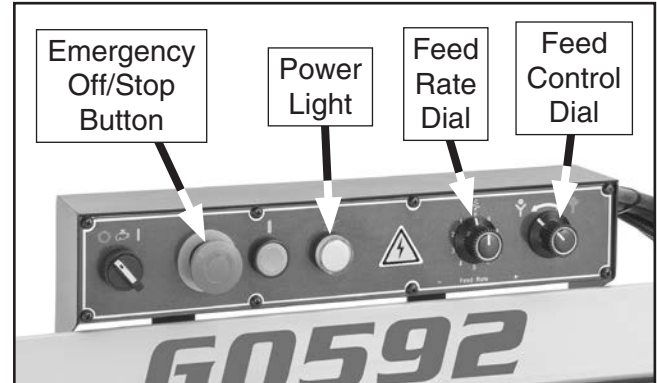

Figure 19. Initial power controls.

6. Twist Emergency Stop/Off button clockwise until it springs out. This resets switch so machine can start.
7. Press Start button to turn machine **ON** (see **Figure 20**).

Motor should run smoothly and without unusual problems or noises.

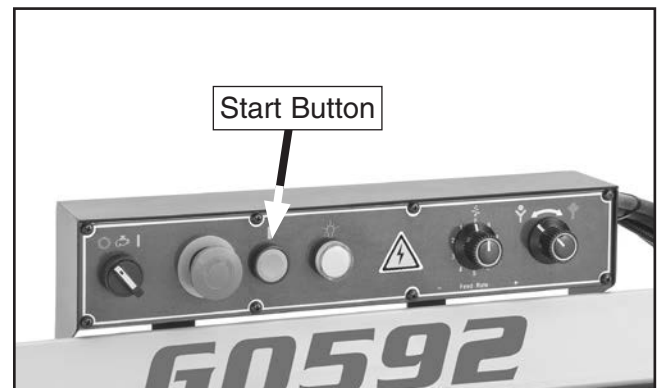

Figure 20. Location of Start button.

8. Press Emergency Stop/Off button to turn machine **OFF**.
9. **WITHOUT** resetting Emergency Stop/Off button, try to start machine by pressing Start button. Machine should not start.

— If machine *does not* start, safety feature of Emergency Stop/Off button is working correctly.



— If machine *does* start, immediately turn it **OFF** and disconnect power. Safety feature of Emergency Stop/Off button is NOT working properly and must be replaced before further using machine.

10. Reset Emergency Stop/Off button and start machine. Rotate feed control dial left. Headstock should slowly lower to bottom of its travel and then blade should turn **OFF**.

— If blade *does not* stop at bottom of headstock travel, immediately press Emergency Stop/Off button and disconnect power. Downfeed limit switch is not adjusted properly and must be adjusted. Refer to **Adjusting Downfeed Stop Bolt on Page 56**.

11. DISCONNECT MACHINE FROM POWER!

12. Add coolant to coolant system (see **Using Coolant System on Page 37**).

NOTICE

Running coolant pump without adequate coolant can significantly damage pump, which will not be covered under warranty.

13. Connect machine to power, raise headstock several inches, then turn feed control dial right to keep it from lowering.

14. Open both coolant valves by turning handles so they are parallel with valves (see **Figure 21**).

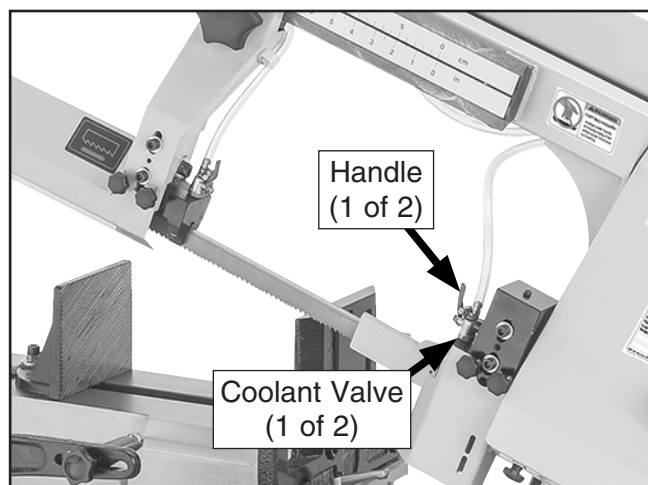

Figure 21. Coolant valves open.

15. Start machine, then turn coolant pump switch to On (I) position (see **Figure 22**). Verify coolant flows through valves and onto blade guides, then turn coolant pump switch to Off (O) position and turn coolant pump **OFF**.

Congratulations! The Test Run is complete.

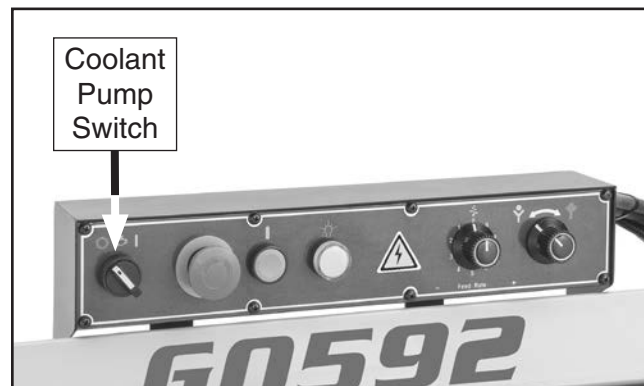

Figure 22. Location of coolant pump switch.

Recommended Adjustments

The adjustments listed below have been performed at the factory. However, because of the many variables involved with shipping, we recommend that you at least verify the following adjustments to ensure accurate cutting results.

Step-by-step instructions on verifying these adjustments can be found in **SECTION 7: SERVICE**.

Factory adjustments that should be verified:

1. Blade Tracking (**Page 54**).
2. Blade Guide Bearings (**Page 52**).
3. Squaring Blade to Table (**Page 55**).
4. Downfeed Stop Bolt (**Page 56**).





SECTION 4: OPERATIONS

Operation Overview

The purpose of this overview is to provide the novice machine operator with a basic understanding of how the machine is used during operation, so the machine controls/components discussed later in this manual are easier to understand.

Due to the generic nature of this overview, it is **not** intended to be an instructional guide. To learn more about specific operations, read this entire manual, seek additional training from experienced machine operators, and do additional research outside of this manual by reading "how-to" books, trade magazines, or websites.

	<p>!WARNING To reduce your risk of serious injury, read this entire manual BEFORE using machine.</p>
--	--

<p>!WARNING To reduce risk of eye injury from flying chips or lung damage from breathing dust, always wear safety glasses and a respirator when operating this machine.</p>	
	

<p>NOTICE If you are not experienced with this type of machine, WE STRONGLY RECOMMEND that you seek additional training outside of this manual. Read books/magazines or get formal training before beginning any projects. Regardless of the content in this section, Grizzly Industrial will not be held liable for accidents caused by lack of training.</p>
--

To complete a typical operation, the operator does the following:

1. Examines workpiece to make sure it is suitable for cutting.
2. Raises headstock, then rotates feed control dial right to secure headstock position.
3. Adjusts vise to left or right side of blade as needed.
4. Adjusts movable vise angle to match workpiece, then securely clamps workpiece in vise.
5. Adjusts headstock angle.
6. Sets up splash guard and work stop if needed for operation.
7. Adjusts upper blade guide as close to workpiece as possible, and verifies blade is properly tensioned.
8. Makes sure workpiece and machine are stable and that there are no obstructions in the way of cut.
9. Puts on safety glasses and respirator.
10. Ensures machine has adequate amount of coolant, then opens coolant valves.
11. Adjusts feed rate dial to desired speed.
12. Starts machine and waits for blade to reach full speed, then adjusts blade speed.
13. Turns **ON** coolant pump.
14. Turns feed control dial left to lower headstock and blade into workpiece, then allows machine to complete cut.
15. Once machine has stopped, raises headstock, turns machine **OFF**, and removes workpiece.



Operation Tips

The following tips will help you safely and effectively operate your bandsaw, and help you get the maximum life out of your saw blades.

Tips for cutting:

- Use work stop to quickly and accurately cut multiple pieces of stock to the same length.
- Clamp workpiece firmly in the vise jaws to ensure a straight cut through the material.
- Allow blade to reach full speed before engaging workpiece. Never start a cut with the blade in contact with the workpiece, and do not start a cut on a sharp edge.
- Chips should be curled and silvery. If the chips are thin and powder-like, increase your feed rate.
- Burned chips indicate a need to reduce your blade speed.
- Wait until blade has completely stopped before removing workpiece from vise. Avoid touching the cut end—it could be very hot!
- Support long pieces so they will not fall when cut. Flag long ends to alert passers-by of potential danger.
- Adjust upper blade guides as close as possible to workpiece to minimize side-to-side blade movement.
- Use coolant when possible to increase blade life.

NOTICE

Loosen blade tension at the end of each day to prolong blade life.

Workpiece Inspection

Before cutting, inspect the material for any of the following conditions and take the necessary precautions:

- **Small or Thin Workpieces:** Small or thin workpieces may be damaged during cutting—avoid cutting these workpieces if possible. If you must cut a small or thin workpiece, attach it to or clamp it between larger scrap pieces that will both support the workpiece through the cut. Some thin sheet metals will not withstand the forces from this bandsaw during cutting; instead, use a shear, nibblers, or sheet metal nippers to cut these pieces.
- **Unstable Workpieces:** Workpieces that cannot be properly supported or stabilized with the vise should not be cut on this bandsaw. Examples are chains, cables, workpieces with internal or built-in moving or rotating parts, etc.
- **Material Hardness:** Always factor in the hardness of the metal before cutting it. Hardened metals will take longer to cut, may require lubrication, and may require a different type of blade in order to efficiently cut them.
- **Tanks, Cylinders, Containers, Valves, Etc.:** Cutting into containers that are pressurized or contain gases or liquids can cause explosions, fires, caustic burns, or machine damage. Avoid cutting any of these types of containers unless you have verified that the container is empty and it can be properly supported during a cut.
- **Magnesium:** Pure magnesium burns easily. Cutting magnesium with a dull blade can create enough friction to ignite the small magnesium chips. Avoid cutting magnesium, if possible.



Using Vise

The vise on the Model G0592 can be positioned for cutting on either side of the vise base, and consists of a movable vise jaw that can be adjusted to match the angle of the workpiece. It also has a ratcheting-type leadscrew that allows for fast movable jaw adjustments.

Note: *Figure 23 shows the correct methods of holding different workpiece shapes.*

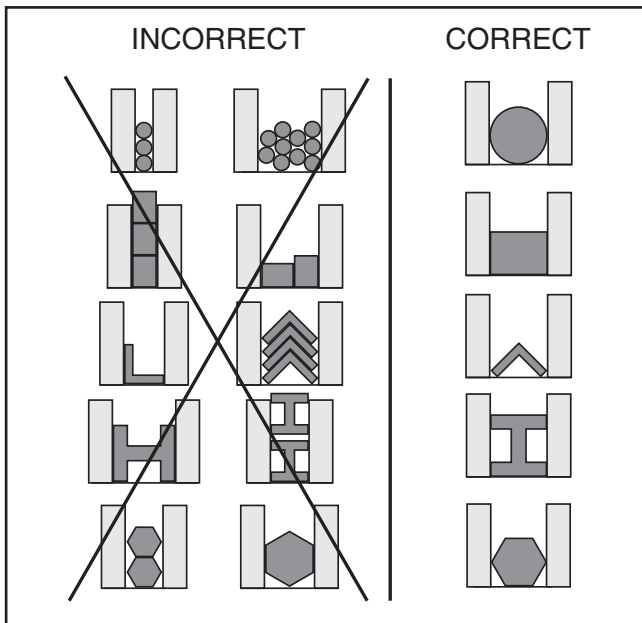

Figure 23. Example of workpiece holding options by material shape.

! WARNING

To avoid serious injury, always turn machine **OFF** and allow blade to come to complete stop before adjusting vise!

Changing Vise Position

1. DISCONNECT MACHINE FROM POWER!
2. Raise headstock all the way, then use feed control dial to keep it from lowering.

3. Loosen (2) vise lock handles (see **Figure 24**).
4. Move vise base to opposite side of track (see **Figure 24**), then tighten vise lock handles to secure.

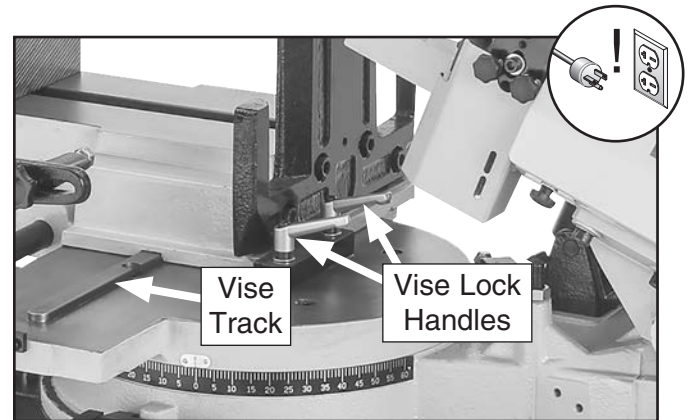

Figure 24. Location of vise lock handles and track.

Opening and Closing Vise

Tool Needed	Qty
Hex Wrench 8mm.....	1

To open and close vise:

1. DISCONNECT MACHINE FROM POWER!
2. Rotate vise handwheel counterclockwise 1/2-turn to relieve any pressure on vise jaws (see **Figure 25**).
3. Flip quick-adjustment latch up to disengage it from vise leadscrew (see **Figure 25**).

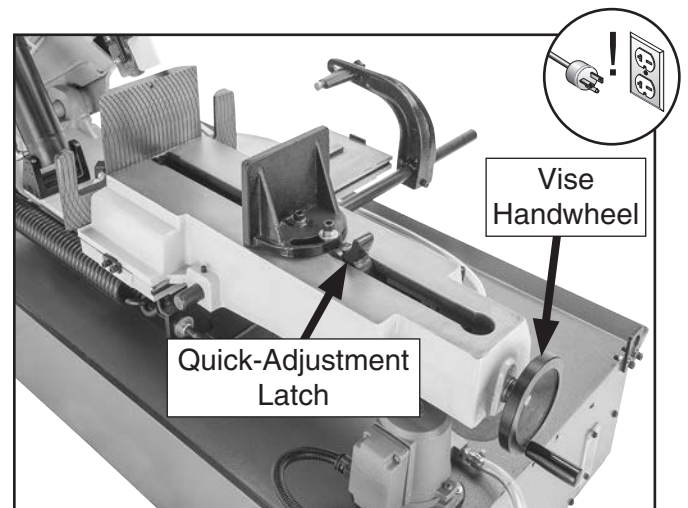

Figure 25. Location of vise handwheel and quick-adjustment latch.



4. Pull or push movable vise jaw in desired direction, as required to accommodate workpiece.
5. Insert workpiece between jaws and engage latch with leadscrew when movable vise is close to workpiece. Use handwheel to move moveable vise jaw until it secures workpiece against fixed vise jaw. If necessary, use stand to support long workpieces to prevent tipping.

— If movable vise jaw angle needs to be adjusted to match workpiece, loosen cap screw shown in **Figure 26** before using handwheel to tighten jaws.

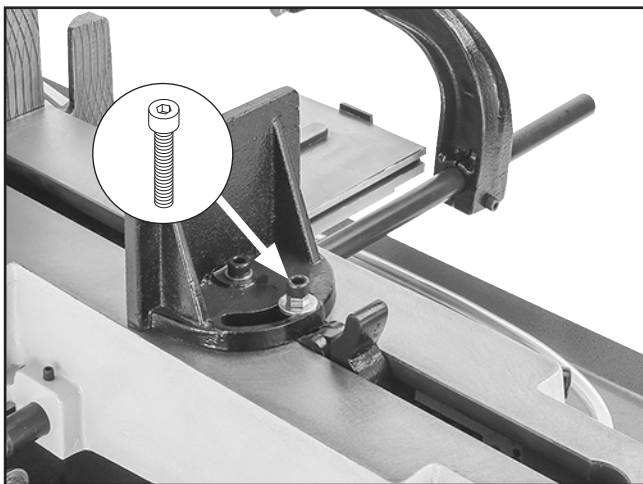

Figure 26. Location of angle cap screw and quick-adjustment latch.

6. If loosened in **Step 5**, tighten angle cap screw.

Selecting Blades

Selecting the right blade for the cut requires a knowledge of various blade characteristics.

Blade Terminology

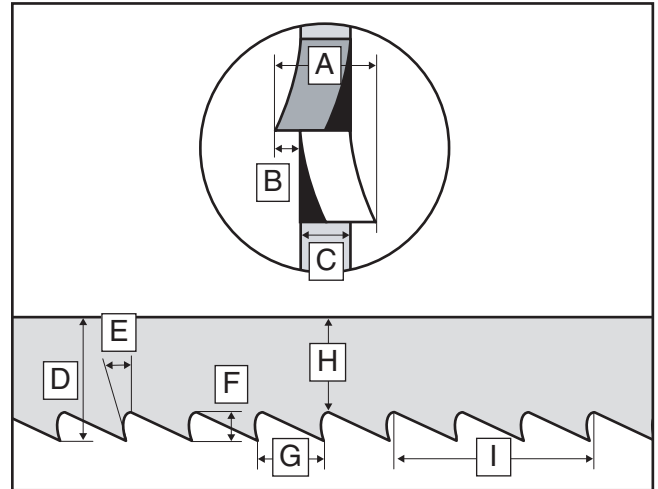

Figure 27. Bandsaw blade terminology.

- A. Kerf:** Amount of material removed by blade during cutting.
- B. Tooth Set:** Amount each tooth is bent left or right from blade.
- C. Gauge:** Thickness of blade.
- D. Blade Width:** Widest point of blade measured from tip of tooth to back edge of blade.
- E. Tooth Rake:** Angle of tooth face from line perpendicular to length of blade.
- F. Gullet Depth:** Distance from tooth tip to bottom of curved area (gullet).
- G. Tooth Pitch:** Distance between tooth tips.
- H. Blade Back:** Distance between bottom of gullet and back edge of blade.
- I. Blade Pitch or TPI:** Number of teeth per inch measured from gullet to gullet.



Blade Length

Measured by the blade circumference, blade lengths are usually unique to the bandsaw model and the distance between the wheels.

Model	Blade Length
G0592.....	132"

Blade Width

Measured from the back of the blade to the tip of the blade tooth (the widest point).

Model	Blade Width
G0592.....	1"

Tooth Type

The most common tooth types are described as follows, and illustrated in **Figure 28**.

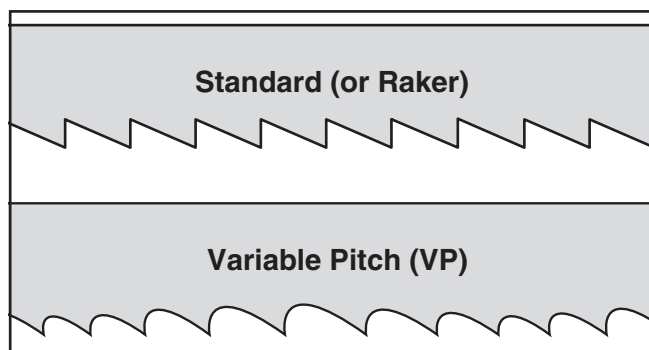

Figure 28. Bandsaw blade tooth types.

Standard or Raker: Equally spaced teeth set at "0" rake angle. Recommended for all purpose use.

Variable Pitch (VP): Varying gullet depth and tooth spacing, "0" rake angle, excellent chip removing capacity, and smooth cutting.

Blade Pitch (TPI)

The chart below is a basic starting point for choosing teeth per inch (TPI) for variable pitch blades and standard raker set bi-metal blades/HSS blades. However, for exact specifications of bandsaw blades that are correct for your operation, contact the blade manufacturer.

To select correct blade pitch:

1. Measure material thickness. This measurement is distance from where each tooth enters workpiece to where it exits workpiece.
2. Refer to "Material Width/Diameter" row of blade selection chart in **Figure 29**, and read across to find workpiece thickness you need to cut.
3. Refer to "Material Shapes" row and find shape of material to be cut.
4. In applicable row, read across to right and find box where row and column intersect. Listed in the box is minimum TPI recommended for variable tooth pitch blades.

The TPI range is represented by a "/" between numbers. For example, 3/4 TPI is the same as 3–4 TPI.

The "Cutting Speed Rate Recommendation" chart, which is located on the machine just below the Blade Pitch Chart, offers guidelines for various metals, given in feet per minute (FPM). Refer to **Blade Speed Chart** section on **Page 32** for further details.

Material Width/Diameter		Teeth Per Inch (TPI) for Bandsaw Blades																					
Material Shapes		TOOTH SELECTION																					
mm		50	75	100	150	200	250	300	350	400	450												
○H△		5/8		4/6		3/4						2/3											
●		4/6		3/4		2/3						1.4/2.5						1.5/8					
▨		3/4				2/3				1.4/2.5						1.5/8							
inch		2	2½	3	3½	4	5	6	7	8	9	10	11	12	13	14	15	16	17	18	19		

Figure 29. General guidelines for blade selection and speed chart.



Changing Blade



⚠ CAUTION
 All saw blades are dangerous and may cause personal injury. To reduce the risk of being injured, wear leather gloves when handling and uncoiling saw blades.

Item(s) Needed	Qty
Metal Brush or Shop Vacuum	1
Assistant	1
Leather Gloves (per person).....	1 Pr.
Phillips Head Screwdriver #2	1
Open-End Wrench 17mm.....	1
Replacement Blade.....	1

Blades should be changed when they become dull, damaged, or when cutting materials that require a blade of a certain type or tooth count.

To change blade:

1. DISCONNECT MACHINE FROM POWER!
2. Raise headstock all the way, then use feed control dial to keep it from lowering.
3. Remove (2) blade covers by loosening (8) knobs shown in **Figure 30**.

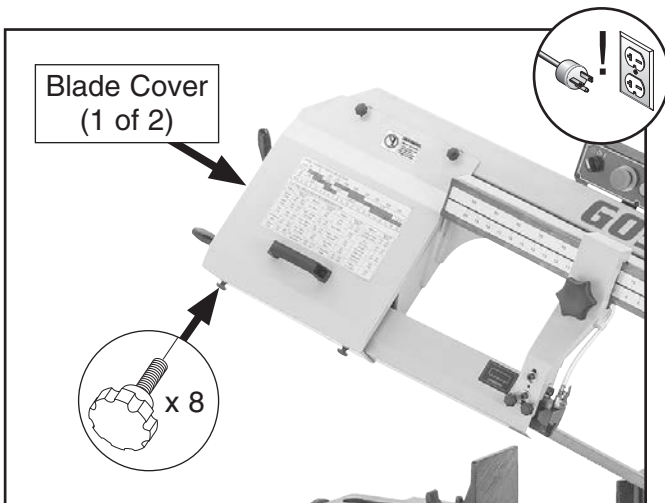

Figure 30. Location of blade covers and knobs.

4. Move upper blade guide as far right as possible (see **Adjusting Upper Blade Guide** on **Page 36**), then clean out all chips and shavings with a brush and shop vacuum.
5. Loosen (2) knobs shown in **Figure 31** to remove front blade guard.

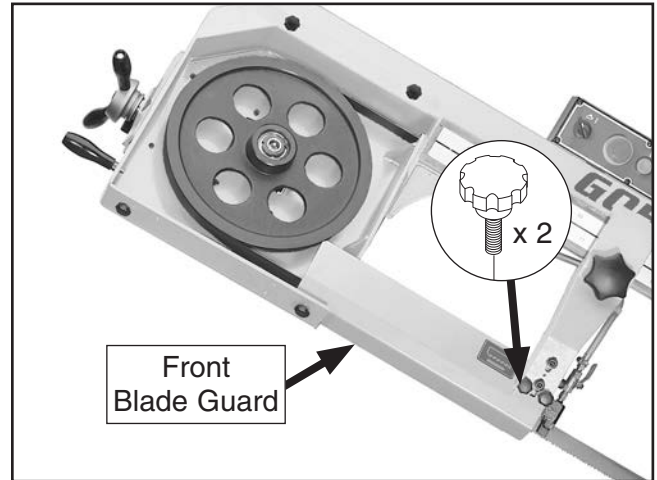

Figure 31. Location of front blade guard and knobs.

6. Remove hex nut, flat washer, and spring shown in **Figure 32** to remove blade brush assembly.

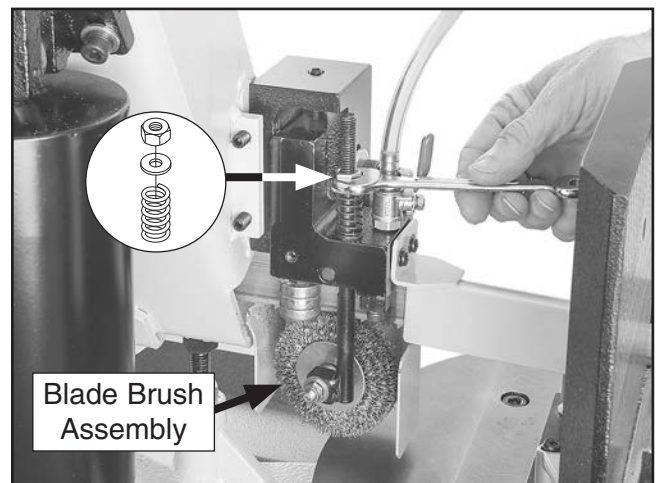

Figure 32. Example of removing blade brush assembly.



7. Loosen (2) knobs shown in **Figure 33** to remove lower rear blade guard.
8. Remove (2) Phillips head screws and flat washers shown in **Figure 33** to remove upper rear blade guard.

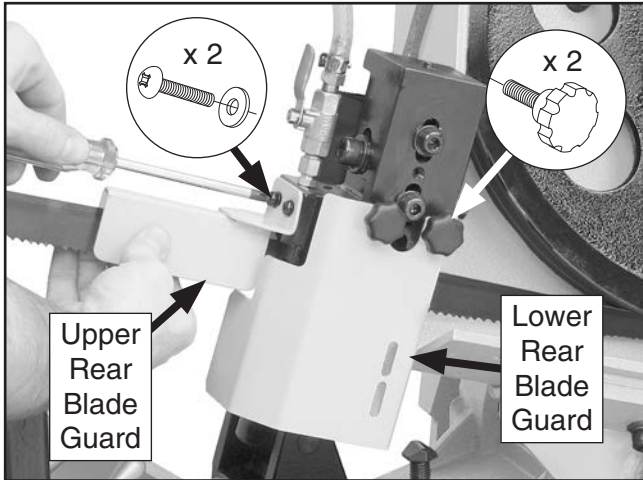

Figure 33. Location of rear blade guards and fasteners.

9. Release blade tension by turning blade tension handle counterclockwise (see **Figure 34**).

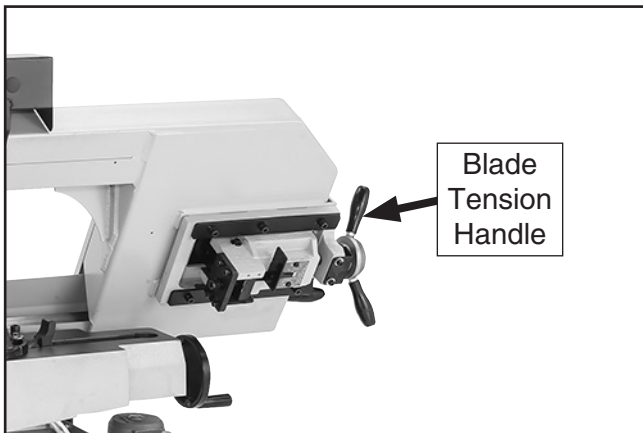

Figure 34. Location of blade tension handle.

10. Remove blade, beginning at top of blade wheels.

11. With help of an assistant, insert new blade through both blade guides and bearings (see **Figure 35**), then position it around wheels.

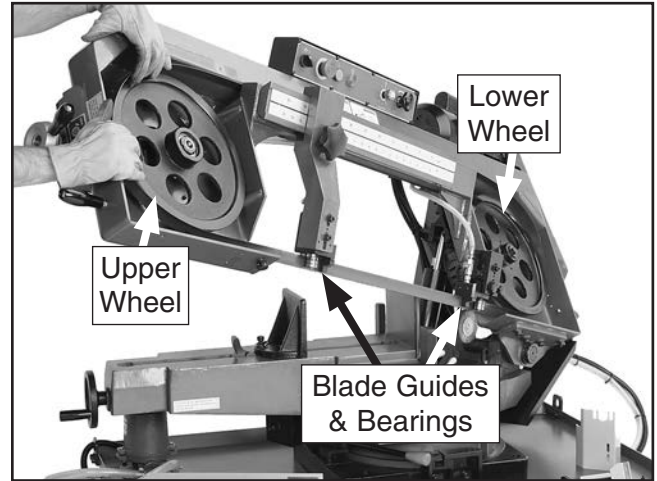

Figure 35. Example of installing blade.

Note: It is sometimes possible to flip the blade inside out, in which case the blade will be installed in the wrong direction. After installing, check to make sure the blade teeth face the same direction as blade travel (see **Figure 36**). Some blades will have a directional arrow as a guide.

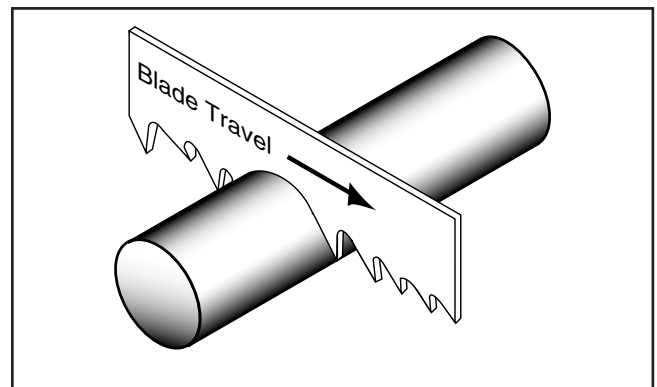

Figure 36. Example of blade cutting direction.



12. Apply a light amount of tension to hold blade in place. Work your way around blade to adjust position so back of blade is against shoulder of wheels, as shown in **Figure 37**.

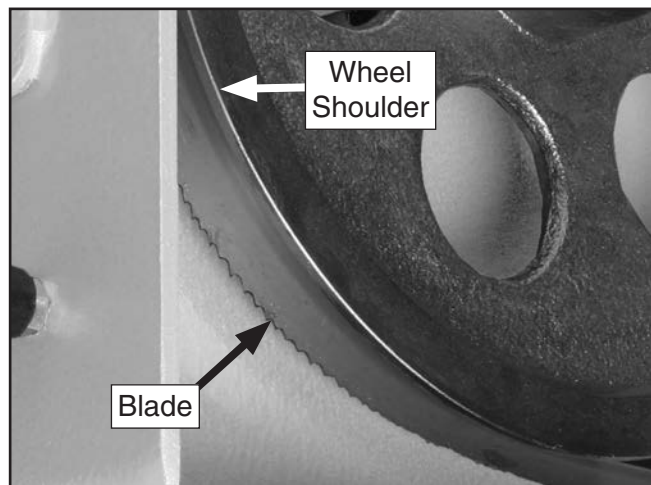

Figure 37. Blade installed on wheel.

13. Perform **Tensioning Blade** procedure that follows this section.
14. Install blade brush and adjust it to blade (see **Adjusting Blade Brush** on **Page 56**).
15. Install blade guards, then install blade covers. Ensure guards do not touch blade.

Tensioning Blade

Proper blade tension is essential to avoid blade vibration, twist, or slippage on the wheels. A correctly tensioned blade provides long blade life, straight cuts, and efficient cutting. The Model G0592 features a blade tension indicator to assist you with blade tensioning.

The three major signs of incorrect blade tension are: 1) the blade stalls in the cut and slips on the wheels, and 2) the blade frequently breaks, and 3) the bandsaw does not make straight cuts.

NOTICE

Loosen blade tension at end of each day to prolong blade life.

To tension blade:

1. DISCONNECT MACHINE FROM POWER!
2. Loosen blade guide knob, move upper blade guide as far left as it will go, then tighten knob to secure (see **Figure 38**).

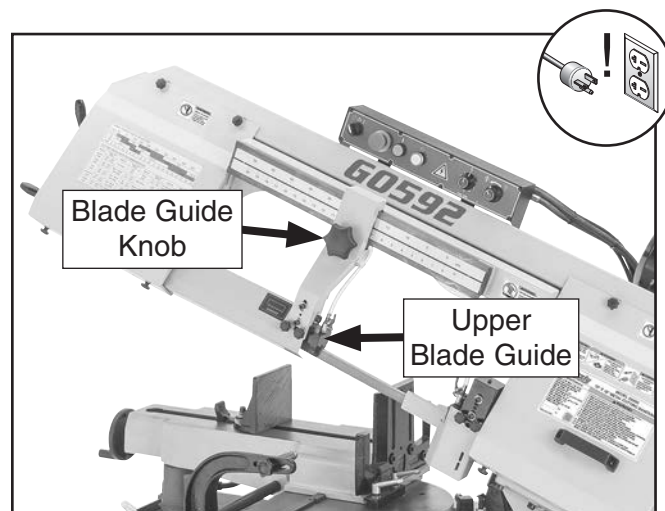

Figure 38. Location of upper blade guide components.



3. Using tension indicator and graduated scale as a guide, turn blade tension handle clockwise to tension blade or counterclockwise to loosen blade (see **Figure 39**).

— For carbon blades, blade tension should be 20,000 PSI.

— For bi-metal blades, like the one supplied with machine, blade tension should be between 30,000–35,000 PSI.

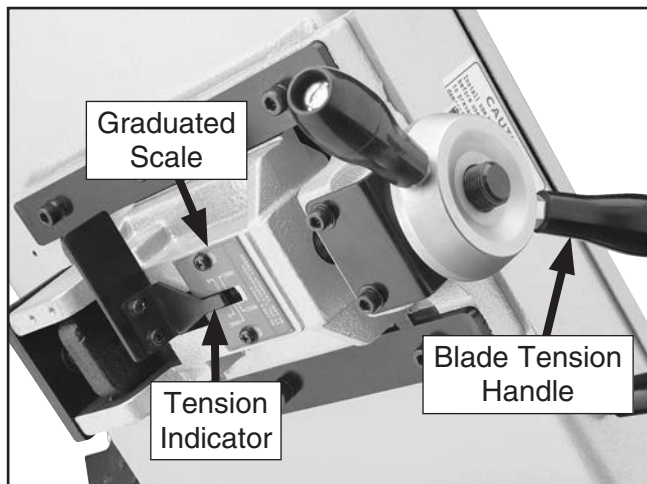

Figure 39. Blade tension components.

Note: To fine-tune blade tension, use blade tensioning gauge like the one found in **Accessories** on **Page 40**. Follow instructions included with gauge and blade manufacturer's recommendations for blade tension.

Blade Breakage

Many conditions may cause a bandsaw blade to break. Some of these conditions are unavoidable and are the natural result of the stresses placed on the bandsaw; other causes of blade breakage are avoidable.

The most common causes of avoidable blade breakage are:

- Faulty alignment or adjustment of the blade guides.
- Feeding blade through the workpiece too fast.
- Dull or damaged teeth.
- Improperly tensioned blade.
- Left blade guide assembly set too far from the workpiece. Adjust left blade guide assembly as close to workpiece as possible.
- Using a blade with a lumpy or improperly finished braze or weld.
- Leaving the blade tensioned when not in use.
- Using the wrong blade pitch (TPI) for the workpiece thickness. The general rule of thumb is to have no fewer than three teeth in contact with the workpiece when starting a cut and at all times during cutting.



Blade Care & Break-In

Blade Care

To prolong blade life, always use a blade with the proper width, set, type, and pitch for each application. Maintain the appropriate feed rate and blade speed, and pay attention to the chip characteristics (Refer to **Blade Speed Chart** on **Page 32** and **Chip Inspection Chart** on **Page 33**). Keep your blades clean, since dirty or gummed up blades pass through the cutting material with much more resistance than clean blades, causing unnecessary heat.

Blade Break-In

The tips and edges of a new blade are extremely sharp. Cutting at too fast of a feed rate or too slow of a blade speed can fracture these tips and edges, quickly dulling the blade. Properly breaking in a blade allows these sharp edges to wear without fracturing, thus keeping the blade sharp longer. Below is a typical break-in procedure. For aftermarket blades, refer to the manufacturer's break-in procedure to keep from voiding the warranty.

Use the **Chip Inspection Chart** on **Page 33** as a guide to evaluate the chips and ensure that the optimal blade speed and feed rate are being used.

To properly break in new blade:

1. Choose correct speed for blade and material type.
2. Reduce feed rate by half for first 50–100 in² of material cut.
3. To avoid twisting blade when cutting, adjust feed rate when total width of blade is in cut.

Changing Blade Speed



Model G0592 blade speeds: 98–394 FPM.

To change blade speeds:

1. Turn bandsaw **ON** and allow motor to reach full speed.
2. Rotate speed adjustment knob (see **Figure 40**) clockwise to decrease blade speed and counterclockwise to increase blade speed.

Note: Viewing window and indicator (see **Figure 40**) on side of knob display approximate speed setting.

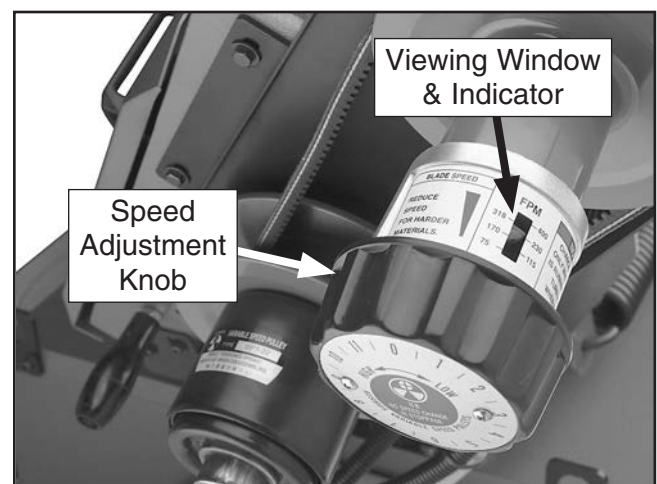

Figure 40. Speed adjustment knob location (belt covers removed for clarity).



Blade Speed Chart

The chart in **Figure 41** offers blade speed guidelines for various metals, given in feet per minute (FPM) and meters per minute (M/Min). Choose the closest available speed on the machine, then adjust the feed rate as necessary, using the appearance of the chips produced as a guide. Refer to the **Chip Inspection Chart** that follows for recommendations on adjusting feed rate or blade speed based on the appearance of the chips produced.

Material	Speed FPM (M/Min)	Material	Speed FPM (M/Min)	Material	Speed FPM (M/Min)	Material	Speed FPM (M/Min)
Carbon Steel	196~354 (60) (108)	Tool Steel	203 (62)	Alloy Steel	111~321 (34) (98)	Free Machining Stainless Steel	150~203 (46) (62)
Angle Steel	180~220 (54) (67)	High-Speed Tool Steel	75~118 (25) (36)	Mold Steel	246 (75)	Gray Cast Iron	108~225 (33) (75)
Thin Tube	180~220 (54) (67)	Cold-Work Tool Steel	95~213 (29) (65)	Water-Hardened Tool Steel	242 (74)	Ductile Austenitic Cast Iron	65~85 (20) (26)
Aluminum Alloy	220~534 (67) (163)	Hot-Work Tool Steel	203 (62)	Stainless Steel	85 (26)	Malleable Cast Iron	321 (98)
Copper Alloy	229~482 (70) (147)	Oil-Hardened Tool Steel	203~213 (62) (65)	CR Stainless Steel	85~203 (26) (62)	Plastics & Lumber	220 (67)

Figure 41. Blade speed chart.



Chip Inspection Chart

The best method for choosing the cutting speed and feed rate for a cutting operation is to inspect the chips created by the cut. These chips are indicators of what is commonly referred to as the "chip load." Refer to the chip inspection chart below to evaluate chip characteristics and determine whether to adjust feed rate/pressure, blade speed, or both.









Chip Appearance	Chip Description	Chip Color	Blade Speed	Feed Rate/Pressure	Other Actions
	Thin & Curled	Silver	Good	Good	
	Hard, Thick & Short	Brown or Blue	Increase	Decrease	
	Hard, Strong & Thick	Brown or Blue	Increase	Decrease	
	Hard, Strong, Curled & Thick	Silver or Light Brown	Good	Decrease Slightly	Check Blade Pitch
	Hard, Coiled & Thin	Silver	Increase	Decrease	Check Blade Pitch
	Straight & Thin	Silver	Good	Increase	
	Powdery	Silver	Decrease	Increase	
	Coiled, Tight & Thin	Silver	Good	Decrease	Check Blade Pitch

Figure 42. Chip inspection chart.



Setting Blade Feed Rate

The speed at which the saw blade will cut through a workpiece is determined by blade type, feed rate, and feed pressure. The feed rate is controlled by two dials on the control panel.

During operation, pay attention to the chips being produced from the cut and compare them to the **Chip Inspection Chart** on **Page 33** to properly set the downfeed rate.

Note: *If a lubricant is used on the cut, the feed rate can be increased by approximately 15%.*

To set blade feed rate:

1. Raise headstock to required height for workpiece, then use feed control dial to keep it from lowering.
2. Adjust feed rate dial shown in **Figure 43** to desired feed rate from 0 (slowest) to 9 (fastest).

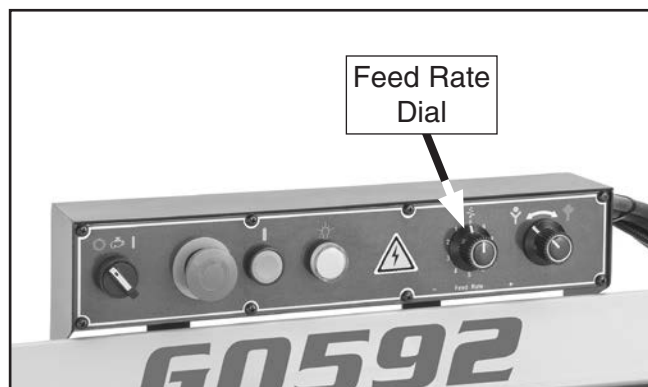

Figure 43. Location of feed rate dial.

3. Turn feed control dial left to lower headstock at set feed rate and perform operation.
4. Examine chips created from cutting operation, and adjust feed rate as necessary for optimum cutting performance (refer to **Chip Inspection Chart** on **Page 33** for details).

Adjusting Cutting Angle

The headstock can be swiveled to cut angles from 60° left to 45° right.

Adjusting to Angle Other than 0°

1. DISCONNECT MACHINE FROM POWER!
2. Raise headstock all the way, then use feed control dial to keep it from lowering.
3. Flip swivel stop out to disengage (see **Figure 44**).

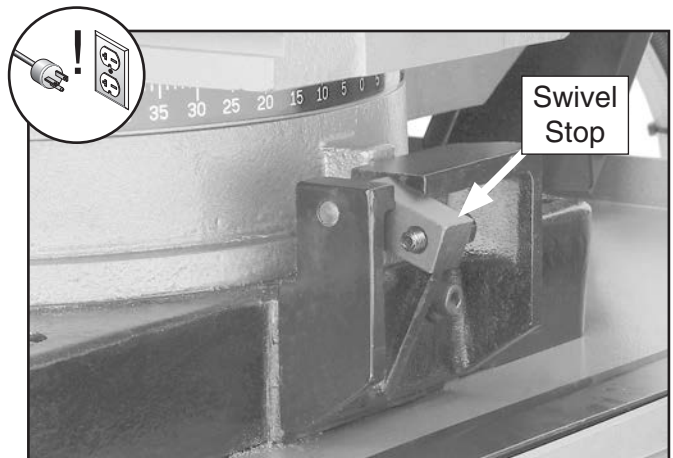

Figure 44. Example of swivel stop disengaged.

4. Loosen swivel lock lever (see **Figure 45**).

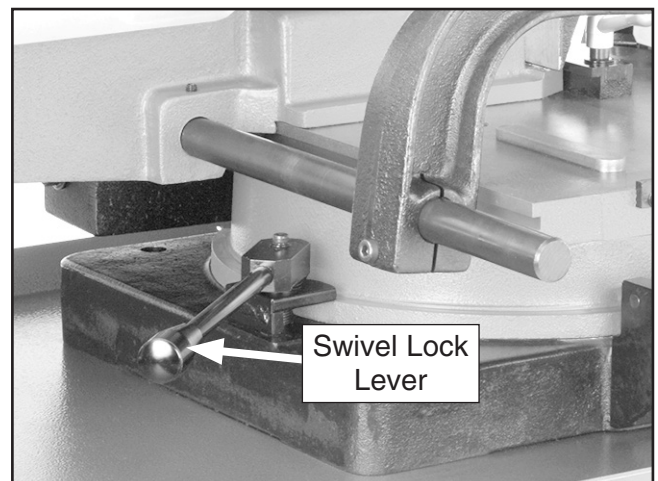

Figure 45. Location of swivel lock lever.



- Using scale and indicator shown in **Figure 46**, use headstock handle to swivel headstock as desired, then tighten swivel lock lever to secure.

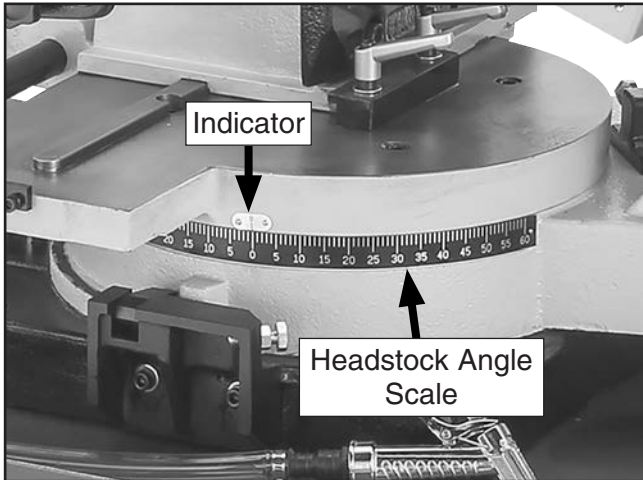

Figure 46. Location of headstock angle scale and indicator.

Adjusting Angle To 0°

- DISCONNECT MACHINE FROM POWER!
- Raise headstock all the way, then use feed control dial to keep it from lowering.
- Loosen swivel lock lever (see **Figure 47**).

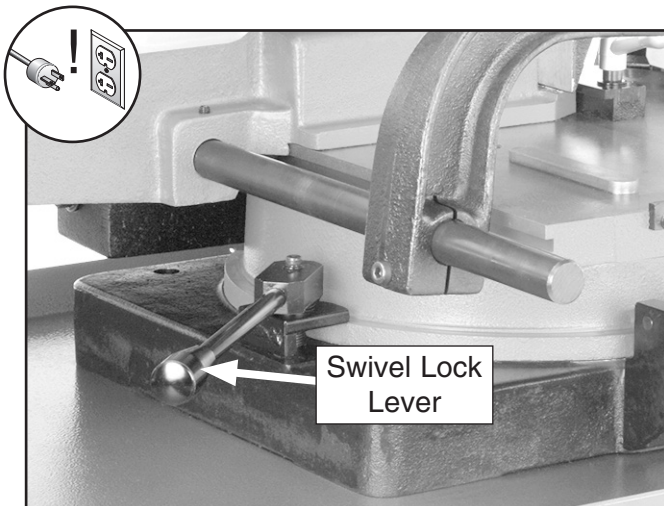

Figure 47. Location of swivel lock lever.

- Using scale and indicator shown in **Figure 48**, use headstock handle to swivel headstock to 0°, then tighten swivel lock lever to secure.

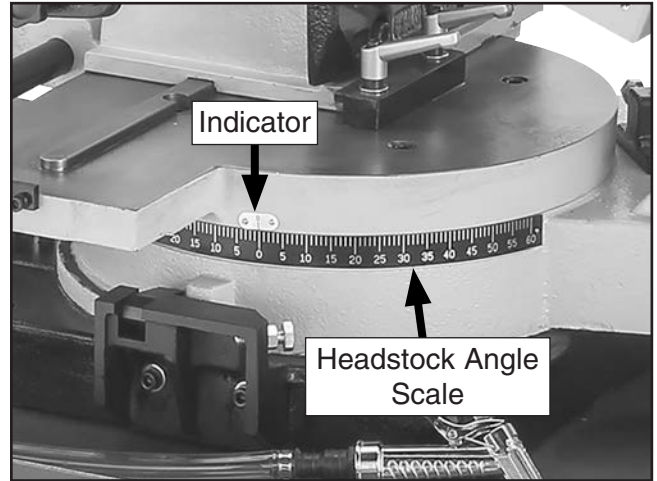

Figure 48. Location of headstock angle scale and indicator.

- Flip swivel stop in to engage (see **Figure 49**).

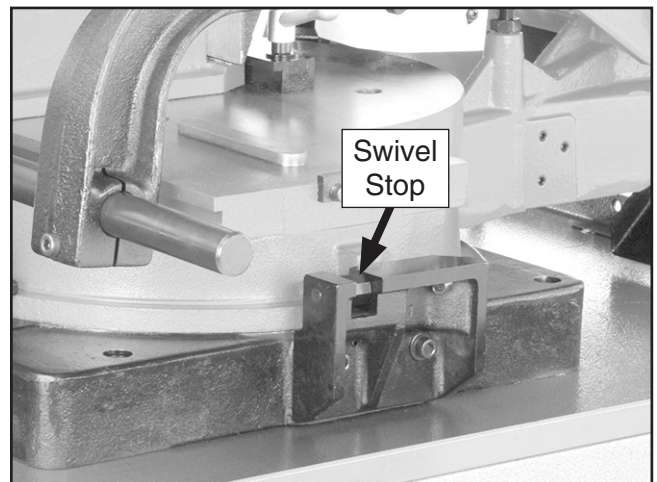

Figure 49. Swivel stop engaged.



Adjusting Upper Blade Guide

The upper blade guide should be as close to the workpiece as possible during cutting operations. This will help ensure straight cuts by keeping the blade from twisting and drifting off the cut line.

To adjust the upper blade guide, loosen the blade guide knob (see **Figure 39**) and slide the upper blade guide as close to the workpiece as possible, then tighten the knob.

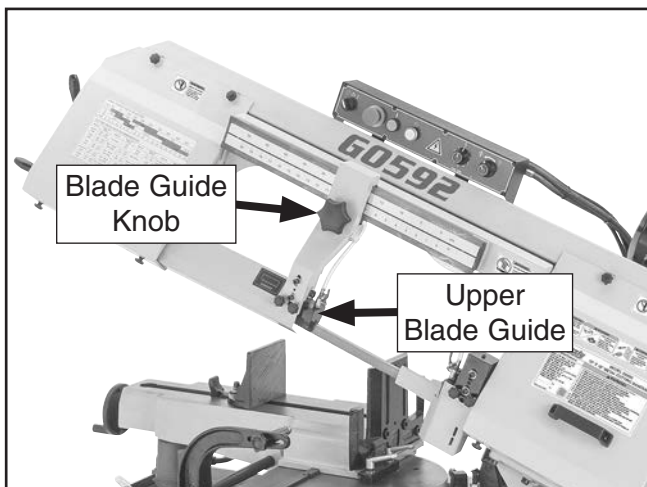

Figure 50. Location of upper blade guide components.

The lower blade guide has a wire brush that makes contact with the blade to help clear away chips and extend blade life (see **Figure 51**).

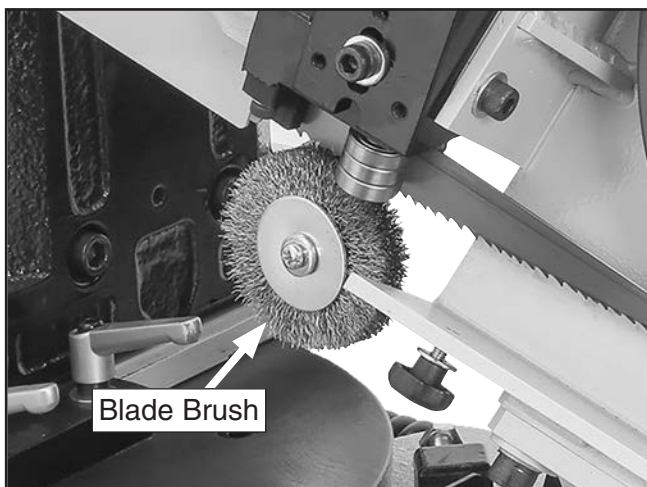

Figure 51. Location of blade brush (lower rear blade guard removed for clarity).

Adjusting Work Stop

The Model G0592 is equipped with a work stop for repetitive cutting operations. The work stop can be installed on either side of the vise and will need to be adjusted any time it is removed or repositioned.

Adjusting Work Stop

Tool Needed	Qty
Hex Wrench 6mm.....	1

To adjust work stop:

1. DISCONNECT MACHINE FROM POWER!
2. Loosen work stop knob (see **Figure 52**), and adjust work stop position in arm as needed for workpiece, then tighten knob to secure.
3. Loosen cap screw shown in **Figure 52** to adjust arm on rod until work stop contacts workpiece, then tighten cap screw to secure.

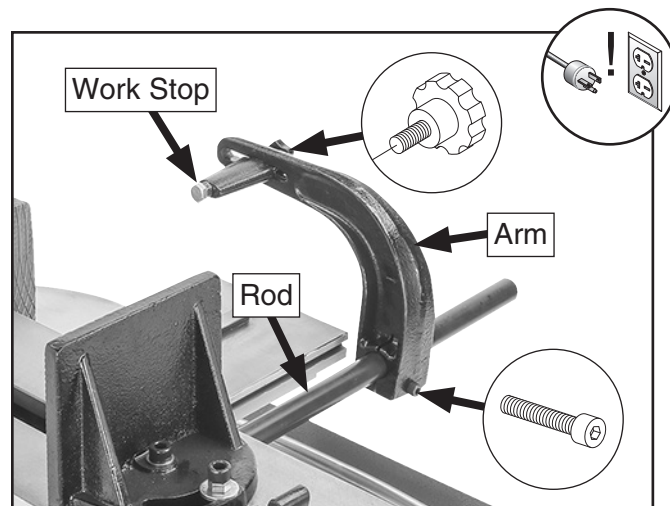

Figure 52. Work stop assembly components.

Repositioning Work Stop

Tool Needed	Qty
Hex Wrench 4mm.....	1

To reposition work stop:

1. DISCONNECT MACHINE FROM POWER!
2. Loosen cap screw shown in **Figure 53** to remove arm from rod.



Using Coolant System

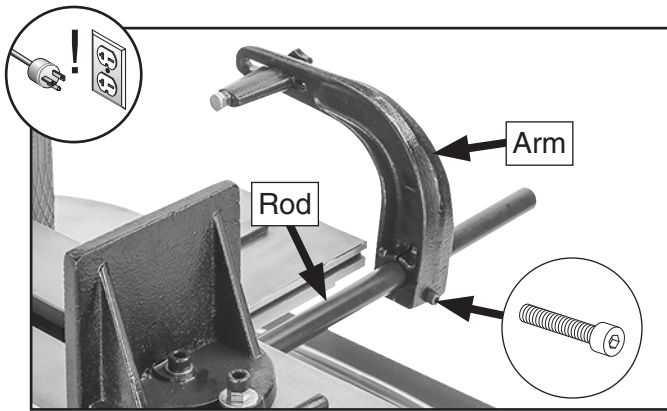

Figure 53. Location of work stop arm and rod.

- Loosen (2) set screws shown in **Figure 54**, slide rod toward other side of vise base, then tighten set screws to secure rod location.

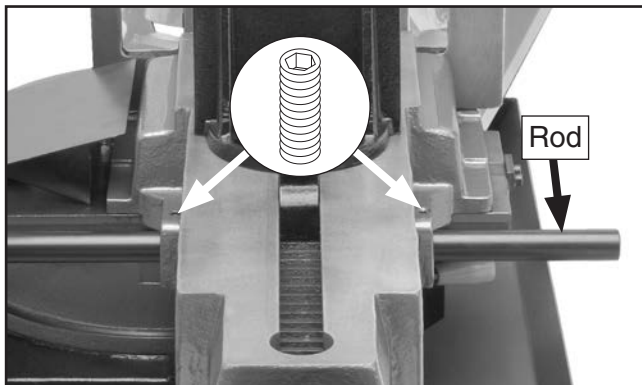

Figure 54. Location of rod and set screws.

- Install arm on rod on opposite side of rod (see **Figure 55**).
- Remove knob, flip work stop, and install knob to secure (see **Figure 55**).

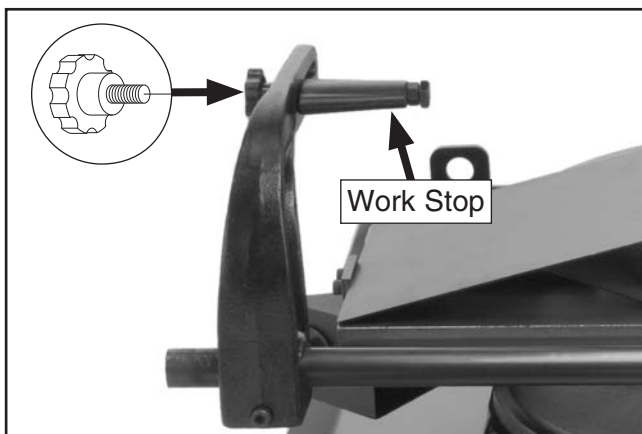

Figure 55. Example of work stop and arm installed on opposite side of rod.

Coolant is a mixture of cutting fluid and water. While simple in concept and function, many issues must be taken into account to mix and use the correct coolant. Always follow all product warnings and specifications, and contact the cutting fluid manufacturer for unanswered questions.

Use the information below as a guideline to choose the appropriate coolant. Always refer to the cutting fluid manufacturer for specific application and safety information:

- For cutting low alloy, low carbon, and general-purpose category metals with a bi-metal blade—use a water soluble cutting fluid.
- For cutting stainless steels, high carbon, and high alloy metals, brass, copper and mild steels—use "Neat Cutting Oil" (commonly undiluted mineral oils) that have extreme pressure additives (EP additives).
- For cutting cast iron, coolant is not recommended.

Tip: *Using a refractometer or hydrometer to replenish water in water-based coolant can extend the life of blades and coolant, and ensure consistent cutting results.*

	<p>! WARNING BIOLOGICAL AND POISON HAZARD!</p>
	<p>Use proper personal protective equipment when handling coolant and follow federal, state, and cutting fluid manufacturer requirements to properly dispose of coolant.</p>





! WARNING
FIRE HAZARD!
DO NOT cut magnesium
when using oil-water
solutions as coolant!
Always use coolant
intended for magnesium.
Water in the solution could
cause magnesium-chip
fire.

This bandsaw has a built-in coolant system that can extend the life of your bandsaw blades by lowering the temperature of the blade and workpiece if used properly when cutting.

NOTICE
 Running coolant pump without adequate coolant can significantly damage pump, which will not be covered under warranty.

Using Coolant System

Add coolant (refer to **Adding Coolant** on **Page 46**), then open the coolant valves (see **Figure 56**) to control the flow of coolant before turning **ON** coolant pump by turning coolant pump switch to ON (I) position (see **Figure 57**).

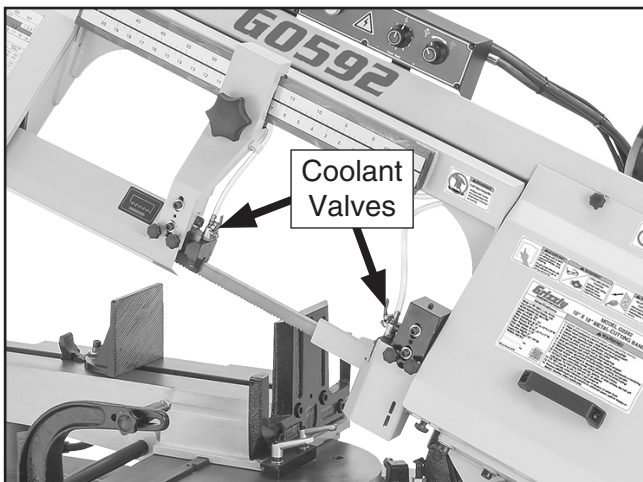

Figure 56. Location of coolant valves.

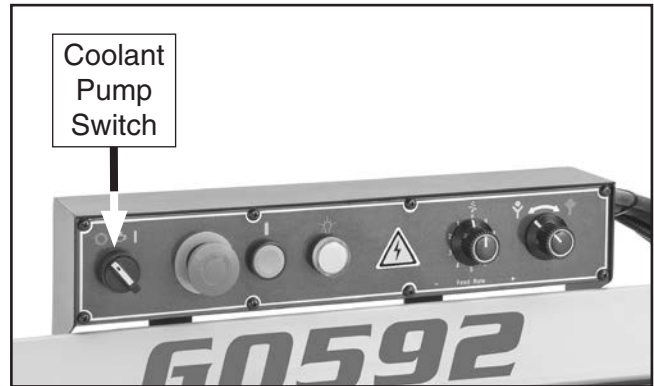

Figure 57. Location of coolant pump switch.

You can also install the splash guard on the base edges (see **Figure 58**) to catch coolant when an operation creates runoff.



Figure 58. Example of splash guard installed on base edge.

Note: *Too much flow at the coolant valves will make a mess and can make the work area unsafe; too little fluid at the cut will overheat the blade, causing the blade teeth to load up and break.*



IMPORTANT: Monitor the coolant level frequently to keep the system working properly. DO NOT let the coolant level fall out of view of the sight glass shown in **Figure 59**.

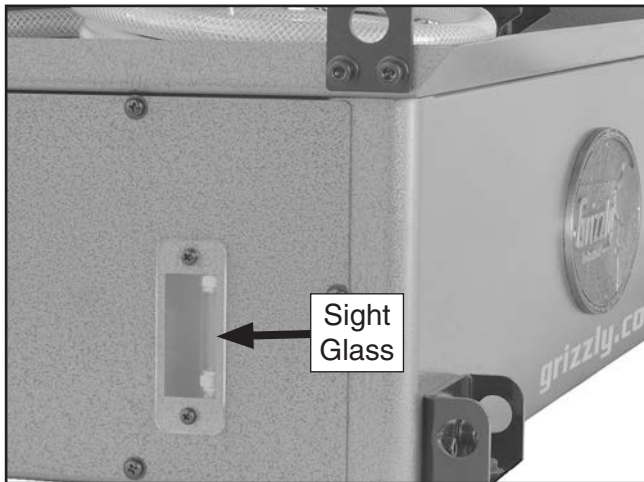

Figure 59. Location of coolant sight glass.

The chip screen shown in **Figure 60** must also be kept clear so coolant can recycle to the coolant reservoir.

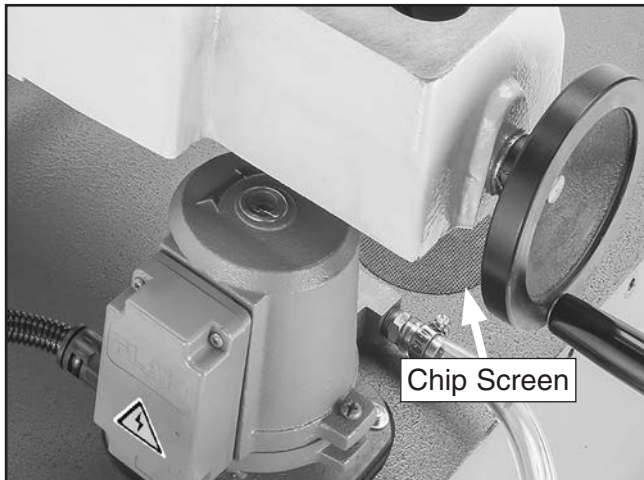

Figure 60. Location of chip screen.

Using Spray Gun

The auxiliary hose and sprayer can be used to rinse metal chips into coolant pan or chip screen.

To use spray gun:

1. Position splash guard on side of base near location of spraying operation.
2. Close coolant valves.
3. Turn coolant pump **ON**. Coolant will now spray when trigger is pressed (see **Figure 61**).

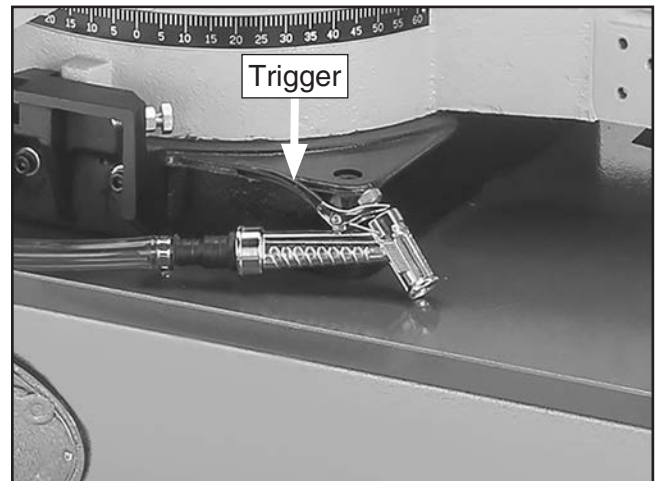

Figure 61. Location of spray gun trigger.



SECTION 5: ACCESSORIES

! WARNING

Installing unapproved accessories may cause machine to malfunction, resulting in serious personal injury or machine damage. To reduce this risk, only install accessories recommended for this machine by Grizzly.

NOTICE

Refer to our website or latest catalog for additional recommended accessories.

H5408—Blade Tensioning Gauge

This gauge ensures long blade life, reduced blade breakage, and straight cutting by indicating correct tension. A precision dial indicator provides you with a direct readout in PSI.



Figure 62. H5408 Blade Tensioning Gauge.

Tool Steel Blades

H2303—132" x 1" x .035" 10 TPI Raker

H2304—132" x 1" x .035" 14 TPI Raker

Variable Pitch Bi-Metal Blades

H1146—132" x 1" x .035" 3–4 Variable Pitch

H1147—132" x 1" x .035" 4–6 Variable Pitch

H1148—132" x 1" x .035" 5–8 Variable Pitch

H1149—132" x 1" x .035" 6–10 Variable Pitch

H1150—132" x 1" x .035" 8–12 Variable Pitch

H1151—132" x 1" x .035" 10–14 Variable Pitch

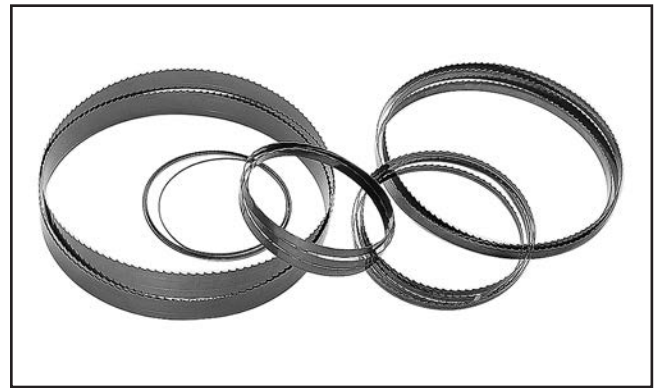

Figure 63. Assorted replacement blades.

G5618—Deburring Tool with 2 Blades

The quickest tool for smoothing freshly machined metal edges. Comes with two blades—one for steel/aluminum and one for brass/cast iron.

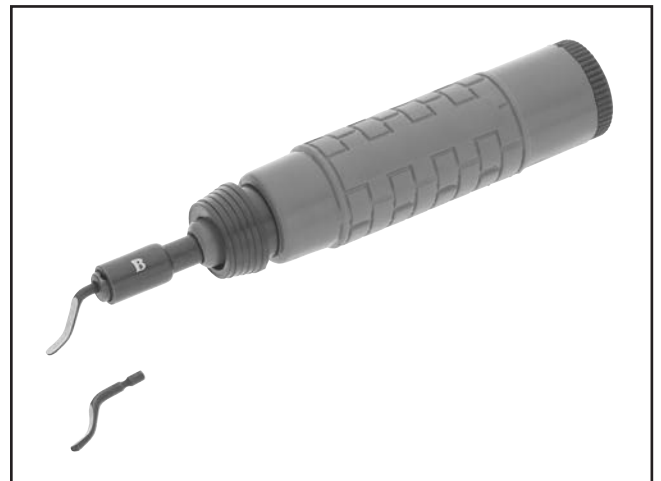

Figure 64. G5618 Deburring Tool with 2 Blades.

order online at www.grizzly.com or call 1-800-523-4777



Basic Eye Protection

T32323—Woodturners Face Shield

T32401—EDGE Brazeau Safety Glasses, Clear

T32402—EDGE Khor G2 Safety Glasses, Tint

T32404—EDGE Mazeno Safety Glasses, Clear



Figure 65. Assortment of basic eye protection.

SB1365—South Bend Way Oil-ISO 68

Engineered for the high pressure exerted on horizontal or vertical ways and slides. Protects against rust and corrosion. Ensures stick-free, smooth motion which maximizes finishes and extends the life of your machine. Won't gum up! 12 oz. AMGA#2 (ISO 68 Equivalent)



Figure 66. SB1365 Way Oil.

T26419—Syn-O-Gen Synthetic Grease

Formulated with 100% pure synthesized hydrocarbon basestocks that are compounded with special thickeners and additives to make Syn-O-Gen non-melt, tacky, and water resistant. Extremely low pour point, extremely high temperature oxidation, and thermal stability produce a grease that is unmatched in performance.



Figure 67. T26419 Syn-O-Gen Synthetic Grease.

T28042—Armor Plate w/Moly-D XHP Gear Oil

This industrial gear oil from Primrose has been developed specifically for significantly higher temperatures and pressures typical of industrial applications. The 514M 6EP equals a ISO 320 viscosity grade.

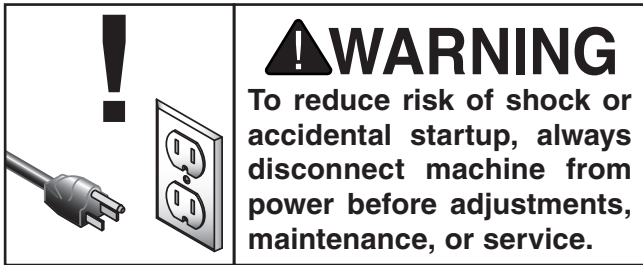

Figure 68. T28042 Moly-D Gear Oil.

order online at www.grizzly.com or call 1-800-523-4777



SECTION 6: MAINTENANCE



Schedule

For optimum performance from this machine, this maintenance schedule must be strictly followed.

Ongoing

To minimize your risk of injury and maintain proper machine operation, shut down the machine immediately if you ever observe any of the items below, and fix the problem before continuing operations:

- Loose mounting bolts.
- Damaged saw blade.
- Worn or damaged wires.
- Low coolant level.
- Incorrect blade tension.
- Any other unsafe condition.

Daily Maintenance

- Lubricate blade and blade guides.
- Clean/protect vise surfaces.
- Check gear box oil level.

Weekly Maintenance

- Lubricate grease fittings.
- Lubricate leadscrews.
- Clean/protect blade guide gib.
- Check gearbox oil level.

Monthly Maintenance

- Check V-belt tension, and for damage or wear.
- Change coolant.

Quarterly Maintenance

- Change gearbox oil.

Cleaning & Protecting

Cleaning the Model G0592 is relatively easy. Use a brush and shop vacuum to remove chips and other debris from the working surfaces.

Protect the unpainted cast iron surfaces by wiping them clean after every use. Keep the surfaces rust-free with regular applications of a rust-preventative lubricant.

Lubrication

Use the schedule below and the following instructions to properly lubricate the other components that require lubrication.

Lubrication Task	Frequency (Hours of Operation)	Page Ref.
Blade & Guides	8 Hrs.	43
Pivot Grease Fittings	40 Hrs.	43
Idler Wheel Grease Fittings	40 Hrs.	43
Vise Leadscrew	40 Hrs.	43
Blade Tension Leadscrew	40 Hrs.	44
Gearbox Oil Check	40 Hrs.	44
Gearbox Oil Flush	50 Hrs.	44

Figure 69. Recommended lubrication tasks.

Item(s) Needed	Qty
ISO 68 Oil (SB1365 or Equivalent).....	As Needed
NLGI#2 Grease (T26419 or Equivalent).	As Needed
Grease Gun.....	1
Mineral Spirits.....	As Needed
Clean Shop Rags.....	As Needed
Stiff Brushes.....	2
ISO 320 Oil (T28042 or Equivalent).....	As Needed
Drain Pan.....	1
Thread-Sealing Tape.....	As Needed



Blade & Blade Guides

Lube Type..... SB1365 or ISO 68 Equivalent
Oil Amount..... 1–2 Drops
Lubrication Frequency..... Daily

Place one or two drops of light machine oil on blade and blade guides (see **Figure 70**) daily, especially when cutting cast iron, as no coolant is required when cutting cast iron.

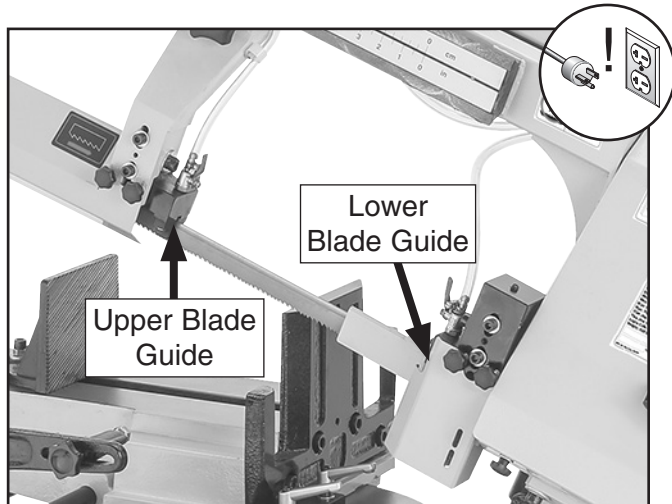

Figure 70. Blade and blade guides.

Pivot Grease Fittings

Lube Type..... T26419 or NLGI#2 Equivalent
Oil Amount..... Thin Coat
Lubrication Frequency..... Weekly

Apply grease to pivot grease fittings shown in **Figure 71**.

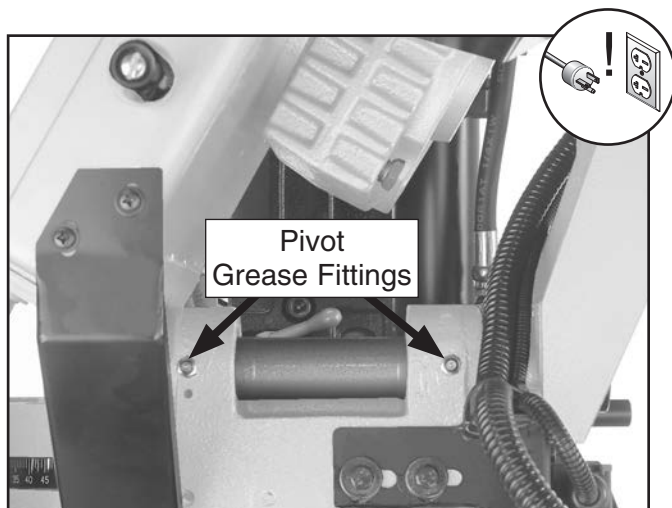

Figure 71. Location of pivot grease fittings.

Idler Wheel Grease Fitting

Lube Type..... T26419 or NLGI#2 Equivalent
Amount..... 1–2 Pumps
Lubrication Frequency..... Weekly

Apply grease to idler wheel grease fitting shown in **Figure 72**.

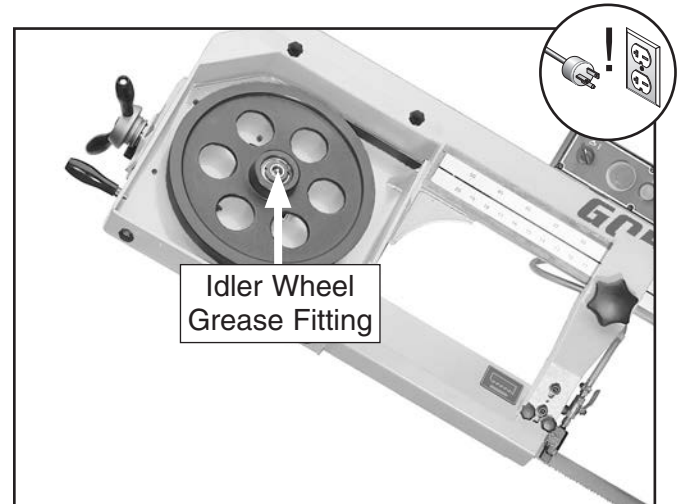

Figure 72. Location of idler wheel grease fitting.

Vise Leadscrew

Lube Type..... SB1365 or ISO 68 Equivalent
Oil Amount..... Thin Coat
Lubrication Frequency..... Weekly

Use mineral spirits, shop rags, and a brush to clean the vise leadscrew. When dry, use a clean brush to apply a thin coat of oil to the leadscrew threads (see **Figure 73**).

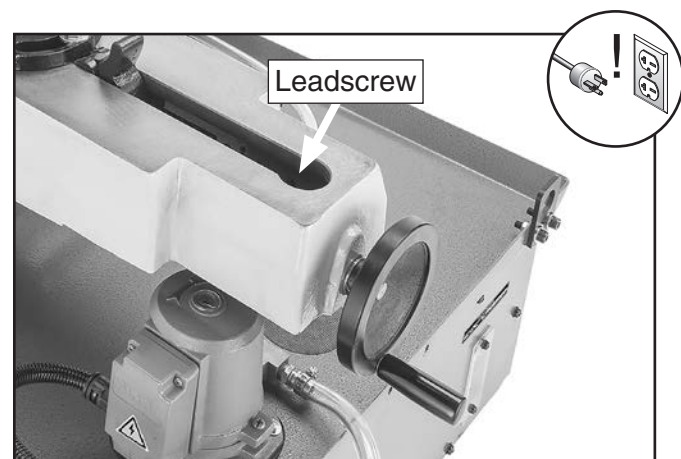

Figure 73. Location of vise leadscrew.



Blade Tension Leadscrew

Lube Type..... SB1365 or ISO 68 Equivalent
Oil Amount.....1–2 Drops
Lubrication Frequency.....Weekly

Lubricate the blade tension leadscrew with 1–2 drops of light machine oil weekly (see **Figure 74**). Wipe off excess oil with a clean rag.

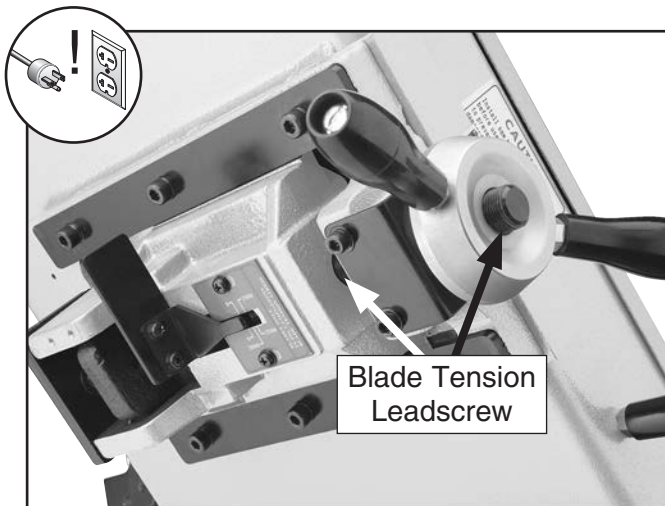

Figure 74. Location of blade tension leadscrew.

Checking/Adding Gearbox Oil

Lube Type..... T28042 or ISO 320 Equivalent
Amount As Needed
Lubrication Frequency.....Weekly

The gearbox oil level should fill the sight glass about halfway full when the headstock is fully lowered. If the oil level drops below this level, add oil as needed using the following steps.

To check gearbox oil:

1. Run machine for 10 minutes to warm up oil in gearbox.
2. DISCONNECT MACHINE FROM POWER!
3. Lower headstock completely.

4. Check oil level in sight glass (see **Figure 75**).
 - If oil level fills about half of sight glass, no oil needs to be added.
 - If oil level fills *less than* half of sight glass, proceed to **Step 5**.
5. Remove fill cap, add oil until it fills half of sight glass, then install fill cap (see **Figure 75**).

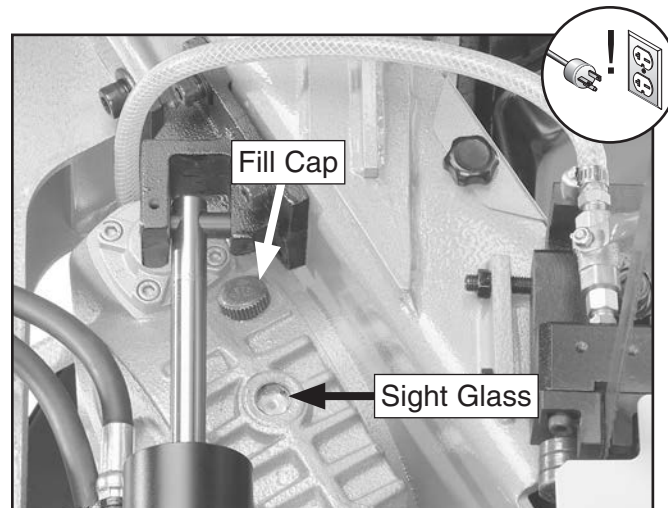

Figure 75. Location of gearbox sight glass and fill cap.

Changing Gearbox Oil

Lube Type..... T28042 or ISO 320 Equivalent
Amount As Needed
Lubrication Frequency..... Quarterly

The gearbox should be drained and refilled after the first 50 hours of use and then once every four months. Use a high quality, ISO 320 grade synthetic gear oil.

To change gearbox oil:

1. Run machine for 10 minutes to warm up oil in gearbox.
2. DISCONNECT MACHINE FROM POWER!
3. Raise headstock all the way, then use feed control dial to keep it from lowering.



4. Remove fill cap (see **Figure 76**).

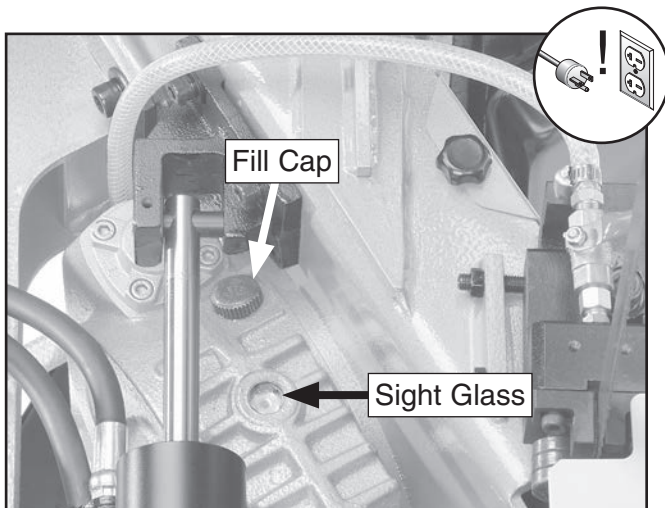

Figure 76. Location of gearbox sight glass and fill cap.

5. With drain pan positioned to catch oil, remove drain plug (see **Figure 77**).

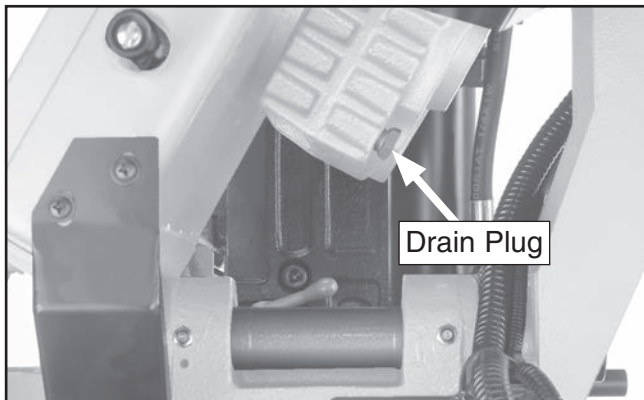

Figure 77. Location of drain plug.

6. When oil is drained, clean threads of drain plug, wrap threads with thread-sealing tape, then install plug.
7. Lower headstock all the way, then fill gearbox at fill cap hole until sight glass is about half-way full (see **Figure 76**).
8. Install fill plug, then connect machine to power and run it for a few minutes before checking oil level (refer to **Checking/Adding Gearbox Oil** on **Page 44**).

Coolant System Maintenance

The coolant system consists of a reservoir, pump, and hoses with valves. The pump collects coolant from the reservoir and sends it to the valves, which control the flow of coolant. As the coolant leaves the work area, it drains through the machine base, where the swarf and metal chips are screened out, and back into the reservoir.

Although most swarf from machining operations is screened out of the coolant before it returns to the tank, small particles will accumulate in the bottom of the reservoir in the form of sludge. To prevent this sludge from being pulled into the pump and damaging it, the pump's intake is positioned above the bottom of the tank. This works well when the tank is regularly cleaned; however, if excess sludge is allowed to accumulate, the pump will inevitably begin sucking it up.

Hazards

As coolant ages and gets used, dangerous microbes can proliferate and create a biological hazard. The risk of exposure to this hazard can be greatly reduced by replacing the old coolant on a monthly basis, or as indicated by the manufacturer of the cutting fluid.

When working with the coolant, minimize exposure to your skin, eyes, and lungs by wearing the proper PPE (Personal Protective Equipment), such as long-sleeve waterproof gloves, protective clothing, splash-resistant safety goggles, and a NIOSH-approved respirator.

	<p>! WARNING BIOLOGICAL & POISON HAZARD! Use correct personal protection equipment when handling coolant. Follow federal, state, and cutting fluid manufacturer requirements for proper disposal.</p>
--	---



Adding Coolant

Items Needed	Qty
Safety Wear.....	See Hazards
Coolant.....	As Needed
Clean Jug or Bucket.....	1
Phillips Head Screwdriver #2.....	1

To add coolant:

1. DISCONNECT MACHINE FROM POWER!
2. Mix coolant according to cutting fluid manufacturer's specifications.
3. Pour coolant through chip screen to fill reservoir with coolant until coolant sight gauge is full (see **Figures 78–79**).

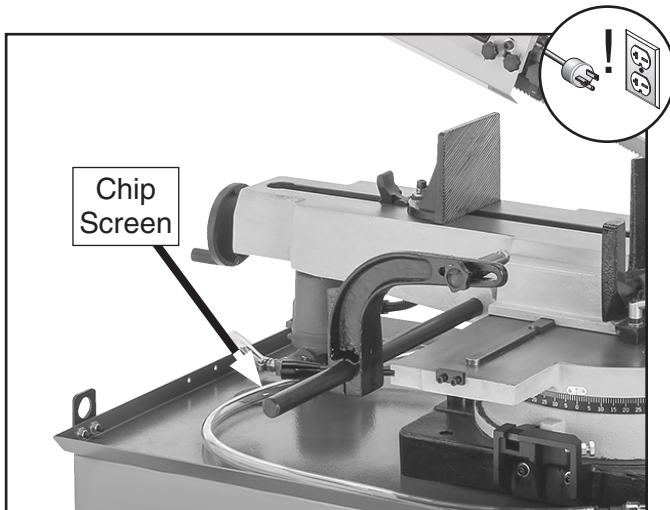

Figure 78. Location of chip screen.

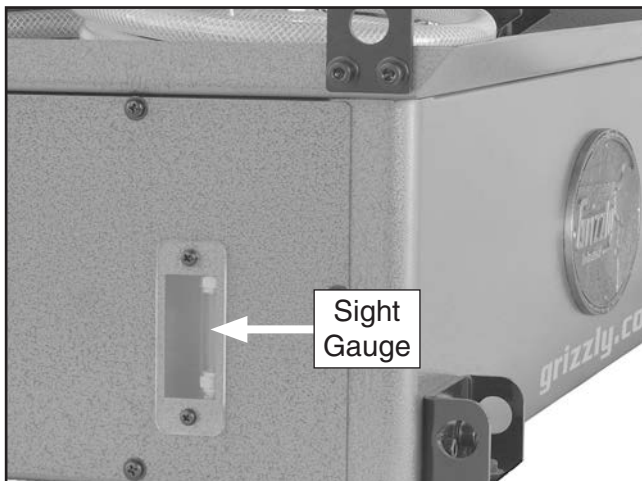

Figure 79. Location of sight gauge.

Changing Coolant

Items Needed	Qty
Safety Wear.....	See Hazards
Coolant.....	4 Gallons
Wrench or Socket 10mm.....	1
Phillips Head Screwdriver #2.....	1
Disposable Shop Rags.....	As Needed
Soap.....	As Needed
Clean Jug or Bucket.....	1

To change coolant:

1. DISCONNECT MACHINE FROM POWER!
2. Remove (4) hex bolts and lock washers shown in **Figure 80** to lift coolant pump out of base. Place it on its side in coolant pan.

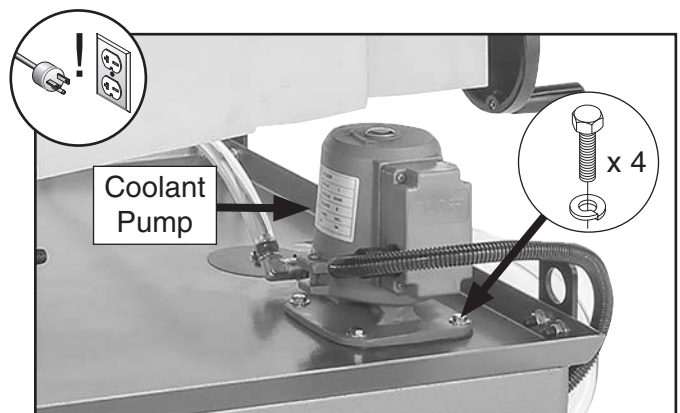

Figure 80. Location of coolant pump and fasteners.

3. Remove (6) Phillips head screws and flat washers shown in **Figure 81** to remove stand cover.

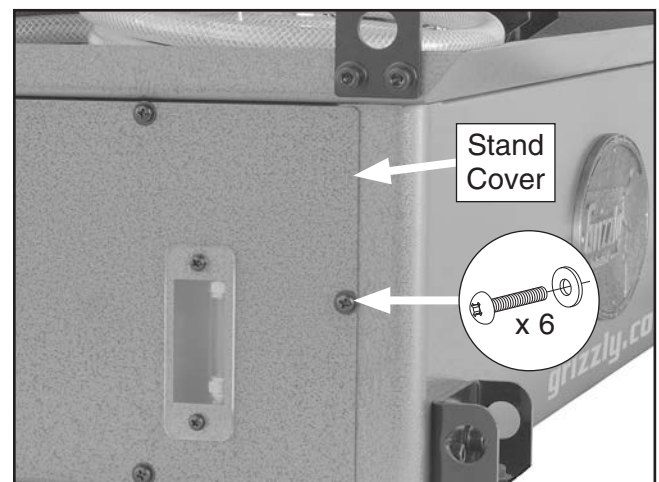

Figure 81. Location of stand cover and fasteners.



4. Remove reservoir (see **Figure 82**) from base and empty it. Dispose of coolant per federal, state, and manufacturer requirements.

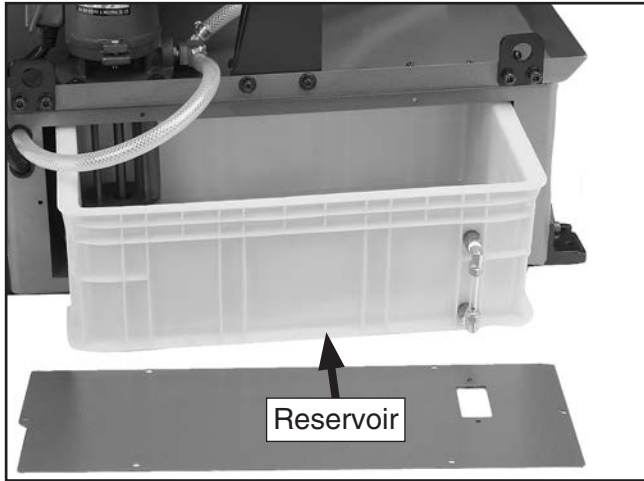

Figure 82. Location of reservoir.

5. Thoroughly clean reservoir and submerge-portion of pump with hot, soapy water, then rinse with clean water.
6. Mix coolant according to cutting fluid manufacturer's specifications.
7. Install reservoir and fill with coolant.
8. Install coolant pump and stand cover.

Storing Machine

All machinery will develop serious rust problems and corrosion damage if not properly prepared for storage. If decommissioning this machine, use the steps in this section to ensure that it remains in good condition.

Preparing Machine for Storage

Items Needed	Qty
T26419 or NLGI#2 Grease Equiv.....	As Needed
Rust Preventative	As Needed
Shop Rags.....	As Needed
Control Tags	As Needed
Desiccant Packs.....	As Needed
Tarp/Plastic Sheet	1

To prepare machine for storage:

1. DISCONNECT MACHINE FROM POWER!
2. Thoroughly clean all unpainted, bare metal surfaces, then coat them with light weight grease or rust preventative. Take care to ensure these surfaces are completely covered but that grease or rust preventative is kept off painted surfaces.
 - If machine will be out of service for only a short period of time, use quality medium-weight machine oil (not auto engine oil) in place of grease or rust preventative.
3. Remove coolant, then add a few drops of way oil and blow out lines with compressed air.
4. Loosen or remove blade so it does not stretch or rust while machine is stored.
 - If machine will be out of service for only a short period of time, start machine once a week and run all gear-driven components for a few minutes. This will put fresh coat of gear oil on gearing components inside gearbox.



— If machine will be out of service for a long period of time, drain, then completely fill gearbox with recommended gear oil so components above normal oil level do not develop rust. (Make sure to put a tag on controls as reminder to adjust gear oil level before starting machine.

5. Place a few moisture-absorbing desiccant pack inside electrical box.
6. Completely cover machine with tarp or plastic sheet that will keep out dust and resist liquid or moisture. If machine will be stored in/near direct sunlight, use cover that will block sun's rays.

Bringing Machine Out of Storage

Items Needed

Qty

Safety Glasses (for each person).....	1 Pr.
Cleaner/Degreaser	As Needed
Shop Rags.....	As Needed

To bring machine out of storage:

1. Remove moisture-absorbing desiccant packs from electrical box.
2. Put on safety glasses.
3. Coat rust preventative with cleaner/degreaser, then let soak for 5–10 minutes.
4. Wipe off surfaces. If cleaner/degreaser is effective, rust preventative will wipe off easily.
5. Repeat **Steps 3–4** as necessary until clean.
6. Check gear oil level (see **Checking/Adding Gear Oil** on **Page 44**).
7. Install or tension blade as described on **Page 27** or **29**.
8. Perform **Test Run** on **Page 20**.



SECTION 7: SERVICE

Review the troubleshooting procedures in this section if a problem develops with your machine. If you need replacement parts or additional help with a procedure, call our Technical Support. **Note:** *Please gather the serial number and manufacture date of your machine before calling.*

Troubleshooting

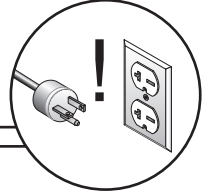

Motor & Electrical

Symptom	Possible Cause	Possible Solution
Motor does not start, or power supply breaker immediately trips after startup.	<ol style="list-style-type: none"> Emergency Stop/Off button depressed/at fault. Downfeed limit switch engaged/at fault. Machine circuit breaker tripped. Blown fuse. Incorrect power supply voltage or circuit size. Plug/receptacle at fault/wired incorrectly. Power supply circuit breaker tripped or fuse blown. Motor wires connected incorrectly. Thermal overload relay has tripped/at fault. Start capacitor at fault. Centrifugal switch adjustment/contact points at fault. Contact not energized/at fault. Wiring broken, disconnected, or corroded. Start button or circuit breaker switch at fault. Motor or motor bearings at fault. 	<ol style="list-style-type: none"> Rotate Emergency Stop/Off button head to reset. Replace if at fault. Raise headstock/adjust downfeed stop bolt and limit switch (Page 56)/replace switch. Reset circuit breaker. Replace fuse/ensure no shorts. Ensure correct power supply voltage and circuit size (Page 12). Test for good contacts; correct wiring. Ensure circuit is free of shorts. Reset circuit breaker or replace fuse. Correct motor wiring connections (Page 61). Reset. Adjust or replace if at fault. Test/replace if at fault. Adjust centrifugal switch/clean contact points. Replace either if at fault. Test all legs for power; replace if necessary. Fix broken wires or disconnected/corroded connections (Page 61). Replace button/circuit breaker switch. Replace motor.
Machine stalls or is underpowered.	<ol style="list-style-type: none"> Dull blade. Feed rate/cutting speed too fast. Wrong workpiece material. Gearbox at fault. Blade slipping on wheels or not properly tensioned. Belt slipping/pulleys misaligned. Motor wires connected incorrectly. Plug/receptacle at fault/wired incorrectly. Pulley slipping on shaft. Machine undersized for task. Motor overheated, tripping machine circuit breaker. Run capacitor at fault. 	<ol style="list-style-type: none"> Sharpen/replace blade (Page 27). Decrease feed rate (Page 34)/cutting speed (Page 31). Use correct type/size of metal. Replace broken or slipping gears. Adjust blade tracking (Page 54) and tension (Page 29). Clean/tension/replace belt (Page 59); ensure pulleys are aligned. Correct motor wiring connections (Page 61). Test for good contacts; correct wiring. Tighten/replace loose pulley/shaft. Use correct, sharp blade; reduce feed rate (Page 34)/depth of cut; use cutting fluid if possible. Clean motor, let cool, and reduce workload. Reset breaker. Test/repair/replace.



Motor & Electrical (Cont.)

Symptom	Possible Cause	Possible Solution
Machine stalls or is underpowered.	13. Extension cord too long. 14. Contactor not energized/at fault. 15. Centrifugal switch/contact points at fault. 16. Motor or motor bearings at fault.	13. Move machine closer to power supply; use shorter extension cord (Page 13). 14. Test all legs for power; repair/replace if at fault. 15. Adjust centrifugal switch/clean contact points. Replace either if at fault. 16. Replace motor.
Machine has vibration or noisy operation.	1. Motor or component loose. 2. Machine leveling hardware not adjusted properly. 3. V-belt worn, loose, pulleys misaligned or belt slapping cover. 4. Pulley loose. 5. Motor mount loose/broken. 6. Workpiece loose. 7. Motor fan rubbing on fan cover. 8. Blade damaged or warped. 9. Centrifugal switch needs adjustment/at fault. 10. Motor bearings at fault. 11. Gearbox at fault.	1. Replace damaged or missing bolts/nuts or tighten if loose. 2. Adjust leveling hardware to stabilize machine. 3. Inspect/replace belt (Page 59). Realign pulleys if necessary. 4. Secure pulley on shaft. 5. Tighten/replace. 6. Reclamp workpiece in vise (Page 24). 7. Fix/replace fan cover; replace loose/damaged fan. 8. Replace warped/damaged blade (Page 27). 9. Adjust/replace if at fault. 10. Test by rotating shaft; rotational grinding/loose shaft requires bearing replacement. 11. Rebuild gearbox for bad gear(s)/bearing(s).
Blade keeps moving after cut is complete.	1. Downfeed limit switch not engaged/at fault.	2. Adjust downfeed stop bolt/limit switch (Page 56); test/replace limit switch if at fault.

Operation

Symptom	Possible Cause	Possible Solution
Vibration when operating or cutting.	1. Loose or damaged blade. 2. Machine component(s) loose. 3. Bent or dull blade. 4. Worn wheel bearing. 5. Wheels worn or incorrectly installed. 6. Wheel appears bent. 7. Gearbox at fault.	1. Tension blade (Page 29)/replace blade (Page 27). 2. Inspect/re-tighten components. 3. Replace blade (Page 27). 4. Check/replace wheel bearing. 5. Replace wheels; adjust blade tracking (Page 54). 6. Check/replace wheel/wheel bearing. 7. Rebuild gearbox; replace bad gear(s)/bearing(s).
Ticking sound when saw is running.	1. Blade teeth missing or broken. 2. Blade weld contacting blade guides. 3. Blade weld failing.	1. Inspect/replace blade (Page 27). 2. Grind weld down flush with blade. 3. Cut and reweld blade, or replace blade (Page 27).
Machine or blade bogs down in cut.	1. Feed rate too fast; blade speed too low. 2. Belt slipping. 3. Blade loading up. 4. Blade dull. 5. Blade not supported; blade tracking incorrectly. 6. Blade TPI incorrect. 7. Blade tension too low. 8. Material requires cutting fluid/lubrication.	1. Reduce feed rate (Page 34); increase blade speed (Page 31). 2. Tension (Page 29)/replace belt (Page 27). 3. Install blade with fewer TPI/different style of teeth (Page 25). 4. Replace blade (Page 27). 5. Move upper blade guide closer to workpiece (Page 36); adjust blade tracking (Page 54). 6. Verify blade has at least 3 teeth contacting material at all times (Page 25). 7. Clean wheels; increase blade tension (Page 29). 8. Use applicable coolant/lubricant (Page 37).



Operation (Cont.)

Symptom	Possible Cause	Possible Solution
Cuts not square, intended angle is not correct.	<ol style="list-style-type: none"> 1. Loose vise. 2. Blade not square to table. 	<ol style="list-style-type: none"> 1. Tighten vise and secure workpiece (Page 24). 2. Adjust blade square to table (Page 55).
Blade dulls prematurely, or metal sticks to blade.	<ol style="list-style-type: none"> 1. Blade improperly broken in. 2. Blade gullets loading up with chips. 3. Blade tension is too low. 4. Blade TPI is too fine or coarse for material; teeth load up and overheat. 5. Incorrect coolant mixture for workpiece/cut. 6. Incorrect feed rate/blade speed. 	<ol style="list-style-type: none"> 1. Replace blade (Page 27); complete blade break-in procedure (Page 31). 2. Use blade with larger gullets (Page 25). 3. Increase blade tension (Page 29). 4. Use coarser-tooth or finer-tooth blade (Page 25); adjust feed rate (Page 34); adjust blade speed (Page 31); make sure blade brush works and is adjusted correctly (Page 56). 5. Use correct coolant mixture (Page 37). 6. Adjust feed rate (Page 34), blade speed (Page 31).
Excessive blade breakage.	<ol style="list-style-type: none"> 1. Workpiece loose. 2. Blade contacting workpiece when starting. 3. Blade too thick/blade gullets too large. 4. Workpiece too coarse for blade. 5. Blade tension/tracking requires adjustment. 6. Blade guide bearings require adjustment. 7. Blade weld failing. 	<ol style="list-style-type: none"> 1. Secure workpiece with vise (Page 24). 2. Raise headstock, start blade, then lower blade into workpiece. 3. Use thinner blade/blade with smaller gullets (Page 25). 4. Use coarser-tooth blade (Page 25); adjust feed rate (Page 34); adjust blade speed (Page 31). 5. Adjust blade tension (Page 29), tracking (Page 54). 6. Adjust blade guide bearings (Page 52). 7. Cut and reweld blade, or replace blade (Page 27).
Blade wears on one side or shows overheating.	<ol style="list-style-type: none"> 1. Blade guides worn or mis-adjusted. 2. Blade not supported. 3. Dull/incorrect blade. 4. Incorrect coolant mixture for workpiece/cut. 5. Blade is bell-mouthed. 	<ol style="list-style-type: none"> 1. Re-adjust guides and bearings (Page 52)/replace. 2. Move upper blade guide closer to workpiece (Page 36). 3. Replace blade (Page 27). 4. Use correct coolant mixture (Page 37). 5. Replace blade (Page 27).
Blade tracks incorrectly, or comes off wheels.	<ol style="list-style-type: none"> 1. Feed rate too fast/wrong TPI. 2. Blade tension/tracking requires adjustment. 3. Blade guides need adjustment. 4. Blade is bell-mouthed. 	<ol style="list-style-type: none"> 1. Reduce feed rate(Page 34)/decrease TPI (Page 25). 2. Adjust blade tension (Page 29), tracking (Page 54). 3. Adjust blade guides (Page 52). 4. Replace blade (Page 27).
Cuts are crooked/ excessively rough.	<ol style="list-style-type: none"> 1. Feed rate too fast/blade speed incorrect. 2. Blade is too coarse or dull. 3. Blade not supported. 4. Carbide blade guides/bearings out of adjustment. 5. Blade tension/tracking requires adjustment. 	<ol style="list-style-type: none"> 1. Reduce feed rate (Page 34); adjust blade speed (Page 31). 2. Replace blade (Page 27). 3. Move upper blade guide closer to workpiece (Page 36). 4. Adjust carbide blade guides/bearings (Page 52). 5. Adjust blade tension (Page 29), tracking (Page 54).
Blade cuts into table or does not fully cut through workpiece.	<ol style="list-style-type: none"> 1. Downfeed stop bolt requires adjustment. 	<ol style="list-style-type: none"> 1. Adjust downfeed stop bolt (Page 56).
Coolant system is not functioning.	<ol style="list-style-type: none"> 1. Coolant valves are closed. 2. Coolant level is low. 3. Coolant system is leaking. 4. Flow blocked or impeded. 	<ol style="list-style-type: none"> 1. Open coolant valves (Page 38). 2. Check/fill coolant (Page 46). 3. Inspect/test for leaks; repair. 4. Make sure coolant line(s) are not pinched, plugged, or damaged.



Operation (Cont.)

Symptom	Possible Cause	Possible Solution
Coolant system is not functioning.	5. Wiring broken, disconnected, or corroded. 6. Coolant pump switch at fault. 7. Coolant pump or pump bearings at fault.	5. Fix broken wires or disconnected/corroded connections (Page 61). 6. Replace switch. 7. Replace pump.
Coolant system is pulling sludge from reservoir.	1. Coolant level is low. 2. Coolant needs to be changed/reservoir is dirty.	1. Check/fill coolant (Page 46). 2. Clean and change coolant (Page 46).

Adjusting Blade Guide Bearings

The support bearings and blade guide bearings come adjusted from the factory, but due to shipping and storage, they may need adjustment. Uneven blade wear and crooked cuts may be the result of improper adjustment.

Tools Needed	Qty
Hex Wrenches 3, 5, 6mm.....	1 Ea.
Phillips Head Screwdriver #2	1
Feeler Gauge 0.002"	1

Adjusting Support Bearings

1. Make sure blade is tensioned and tracking correctly (**Pages 29 and 54**).
2. DISCONNECT MACHINE FROM POWER!
3. Raise headstock all the way, then use feed control dial to keep it from lowering.
4. Loosen (2) knobs shown in **Figure 83** to remove front blade guard.

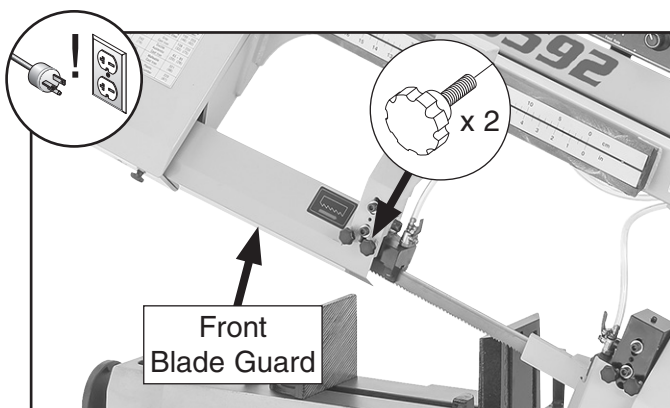

Figure 83. Front blade guard and knobs.

5. On upper blade guide, verify that back of blade lightly contacts support bearing.
 - If it does not, loosen cap screws shown in **Figure 84**, move blade guide assembly up or down until support bearing lightly touches back of blade, then tighten cap screws.

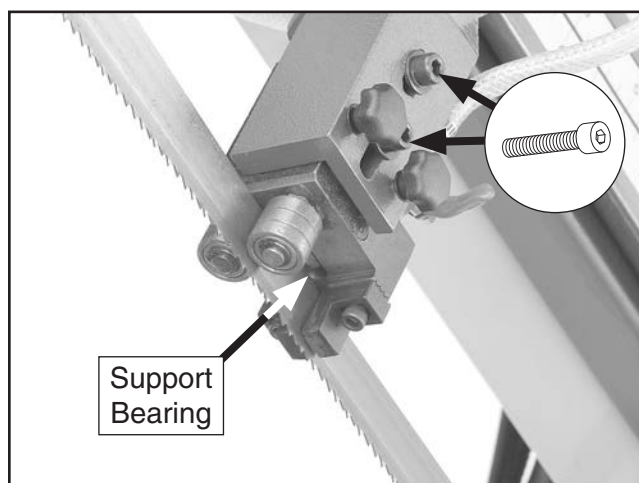

Figure 84. Location of support bearing adjustment components.

Note: If it is difficult to slide blade guide assembly, adjust roller bearings and carbide guides away from blade (refer to next sub-section). It can also help to clean blade guide assembly (refer to **Cleanup** on **Page 15**).

6. Loosen (2) knobs shown in **Figure 85** to remove lower rear blade guard.
7. Remove (2) Phillips head screws and flat washers shown in **Figure 85** to remove upper rear blade guard.



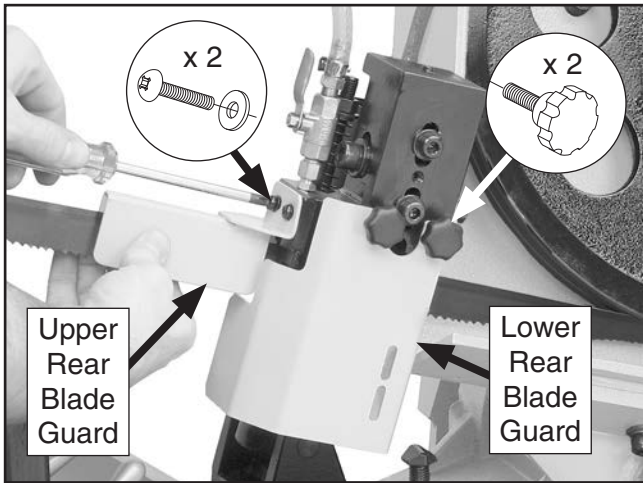

Figure 85. Location of rear blade guards and fasteners.

8. Repeat **Step 5** on lower blade guide.
9. Adjust blade guide bearings (refer to next sub-section).

Adjusting Blade Guide Bearings

1. On upper blade guide, loosen (2) set screws shown in **Figure 86** to allow guide bearings on upper blade guide to turn.
2. Turn each eccentric shaft until guide bearings (see **Figure 86**) lightly contact blade or have maximum clearance of 0.002".

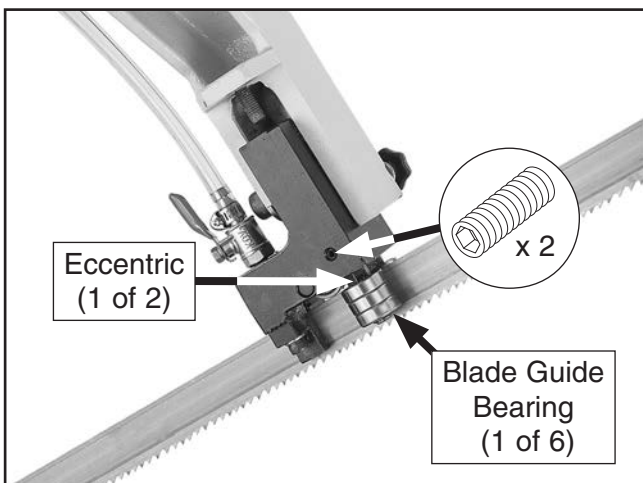

Figure 86. Location of blade guide bearing adjustment components.

Note: Since bearings twist blade position, it is acceptable if there is 0.001"–0.002" gap between blade and front or back bearing. Just make sure not to squeeze blade too tightly with bearings. After guide bearings are set, you should be able to rotate guide bearings (although they will be stiff) with your fingers.

3. Tighten set screws.
4. Loosen (2) cap screws shown in **Figure 87**.
5. Adjust carbide blade guides (see **Figure 87**) so they make same contact with blade as guide bearings, then tighten cap screws.

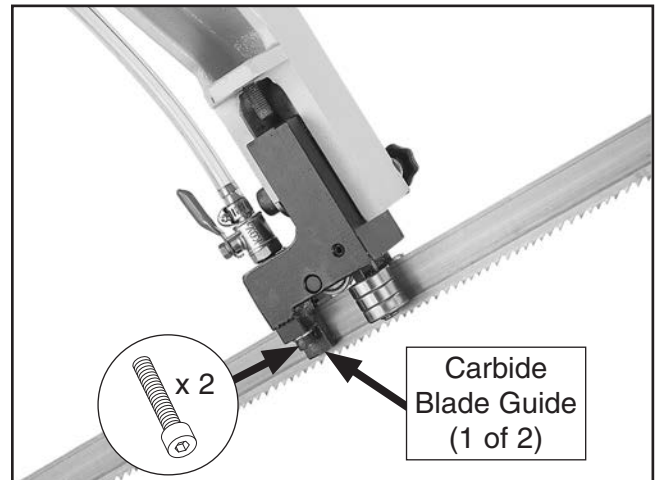

Figure 87. Location of carbide blade guide adjustment components.

6. Repeat **Steps 1–5** on lower blade guide.
7. Install blade guards.
8. Adjust blade brush (see **Adjusting Blade Brush** on **Page 56**).



Adjusting Blade Tracking

The blade tracking has been properly set at the factory. The tracking will rarely need to be adjusted if the bandsaw is used properly.

If the blade comes off the wheels, or if the blade bogs down in a cut, these are signs that the tracking needs to be adjusted. Before adjusting the blade tracking, however, be sure that the feed rate and blade speed are correct, the blade is not dull and has correct teeth style and TPI for material, the blade tension is correct, and the blade is properly lubricated.

Tool Needed	Qty
Hex Wrench 8mm.....	1

To adjust blade tracking:

1. Make sure blade is properly tensioned (see **Tensioning Blade** on **Page 29**).
2. **DISCONNECT MACHINE FROM POWER!**
3. Raise headstock all the way.
4. Remove (2) blade covers by loosening (8) knobs shown in **Figure 88**.

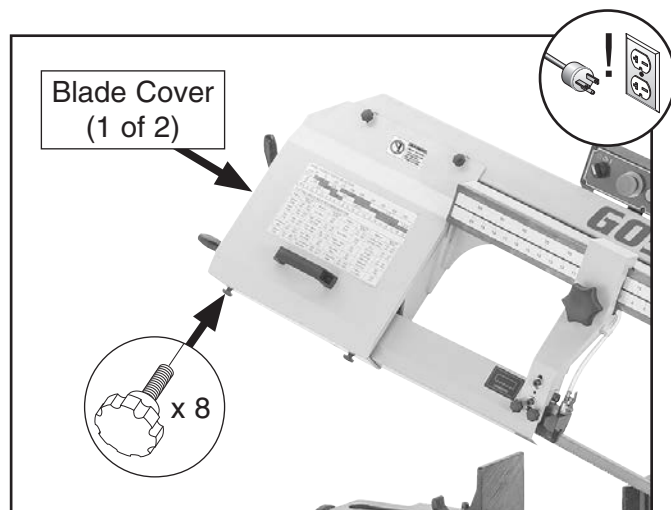

Figure 88. Location of blade covers and knobs.

5. Slide end of a fingernail between back of blade and wheel shoulder (see **Figure 89**).

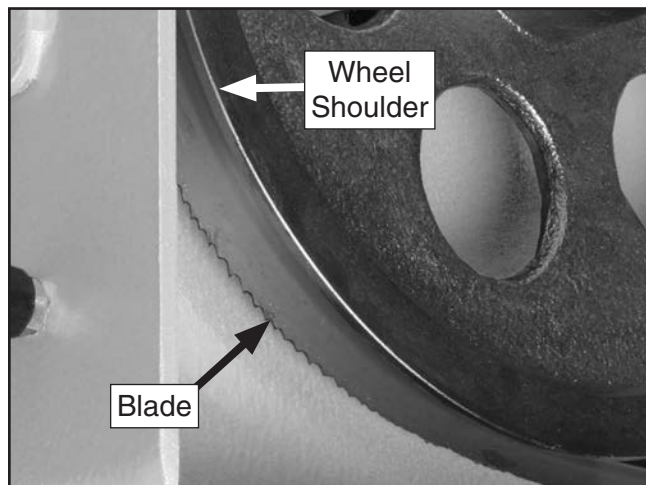

Figure 89. Location of wheel shoulder.

— If there *is* just enough space to slide fingernail between blade and shoulder, no adjustment is necessary. Proceed to **Step 7**.

— If there is *too much* space, or *is not* enough space to slide fingernail between blade and shoulder, proceed to **Step 6**.

6. Adjust tracking cap screw (see **Figure 90**) until blade tracks properly.

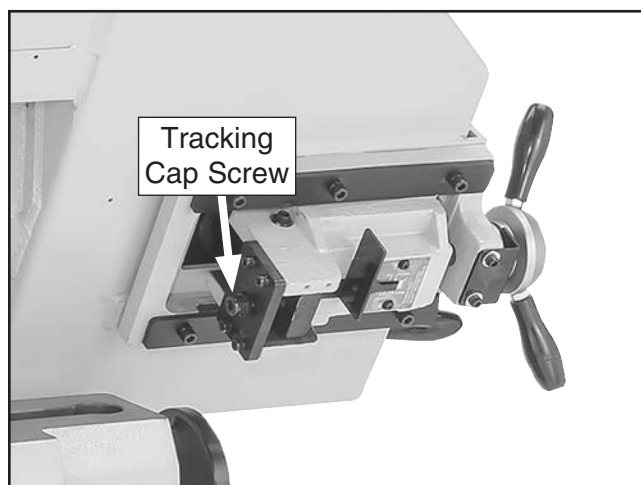

Figure 90. Location of tracking cap screw.

7. Install blade covers.



Squaring Blade to Table

This adjustment has been made at the factory and should not need to be adjusted under normal circumstances. However, if you find the saw is not cutting square, you may need to adjust the blade. Only make this adjustment after factors such as excessive feed rate or the blade guide being set too far away from the workpiece have been ruled out.

Tools Needed	Qty
Machinist's Square	1
Hex Wrenches 3, 6mm.....	1 Ea.

To square blade to table:

1. Lower headstock all the way.
2. DISCONNECT MACHINE FROM POWER!
3. Place square on vise table and against edge of blade (see **Figure 91**), and check different points along length of vise table between blade guide assemblies.

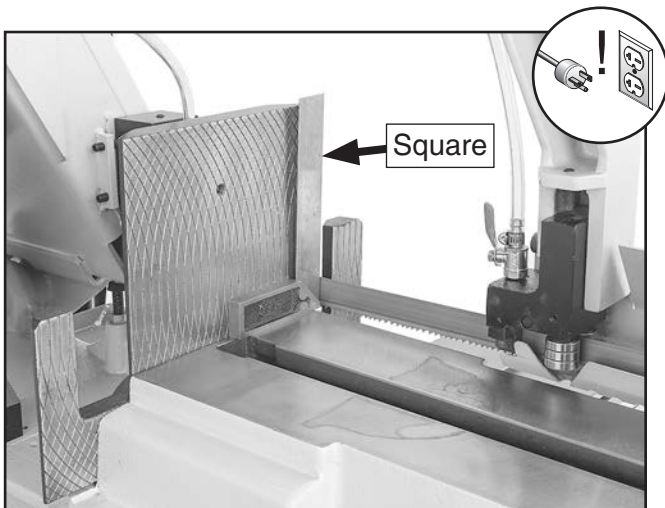

Figure 91. Checking blade squareness.

- If blade *is* square to table, no adjustment is necessary.
- If blade *is not* square to table, proceed to **Step 4**.

4. Loosen (2) cap screws shown in **Figure 92** 1–2 turns on each blade guide assembly.
5. Adjust set screw shown in **Figure 92** until blade is square to vise table.

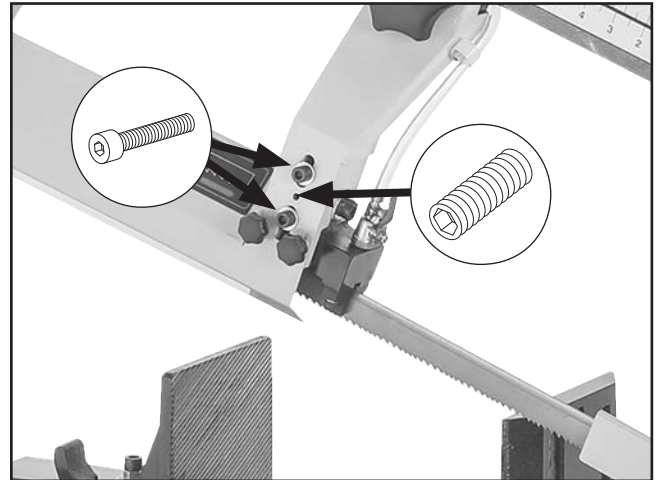

Figure 92. Fasteners for adjusting blade squareness.

6. Tighten cap screws.
7. Repeat **Steps 3–6** until blade is perfectly square to table.

Tip: Cut small sections from scrap piece of material with known square end and measure for uniform thickness. If thickness is not uniform, repeat adjustments above until your personal requirements are met.



Adjusting Blade Brush

The Model G0592 has a blade brush to help keep metal chips off the blade wheels. Use this section to install the brush correctly after installing a blade.

This brush will wear over time and require adjustment when it no longer makes proper contact with the blade. This is considered a normal wear item and is not covered by the warranty.

Tool Needed	Qty
Open-End Wrench 17mm.....	1

To adjust blade brush:

1. DISCONNECT MACHINE FROM POWER!
2. Adjust hex nut shown in **Figure 93** until blade extends $\frac{1}{8}$ " into bristles of brush.

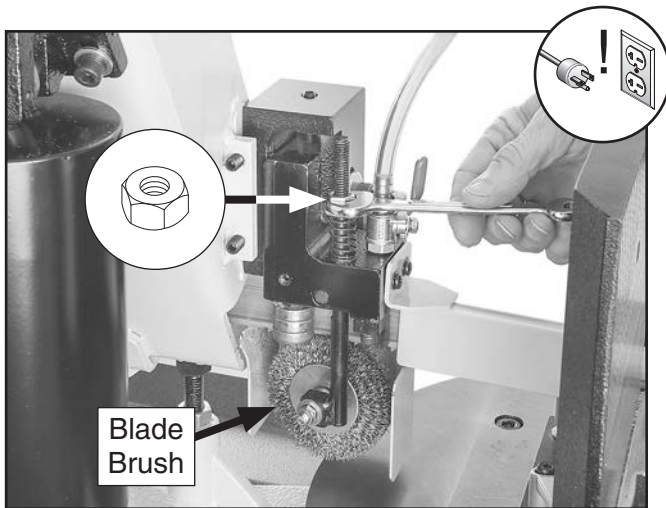

Figure 93. Example of adjusting blade brush.

Adjusting Downfeed Stop Bolt

If the blade does not travel far enough to complete the cut, or the blade contacts the vise base, then the downfeed stop bolt will need to be adjusted. When the downfeed stop bolt is adjusted, the downfeed limit switch should be adjusted to match where the blade stops at the end of the cut.

Tools Needed	Qty
Open-End Wrenches 19mm.....	2
Hex Wrench 4mm.....	1

To adjust downfeed stop bolt:

1. DISCONNECT MACHINE FROM POWER!
2. Lower headstock all the way. When headstock stops, blade teeth should be just below table surface, but not contacting vise base (see **Figure 94**).

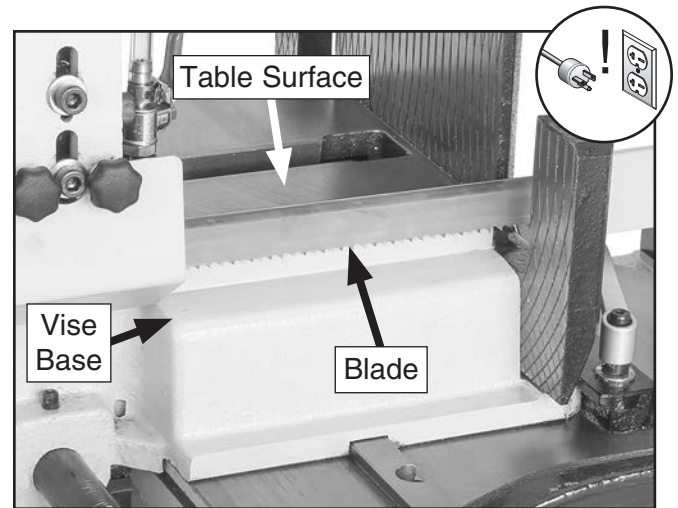

Figure 94. Example of blade below table surface but not contacting vise base.

— If blade contacts vise base, raise headstock until blade teeth are just below table surface, then use feed control dial to secure. Proceed to **Step 4**.

— If blade is above table surface, proceed to **Step 3**.



- Loosen jam nut shown in **Figure 95**, then tighten downfeed stop bolt until blade is just below table surface.
- Loosen downfeed stop bolt (see **Figure 95**) until it contacts headstock.

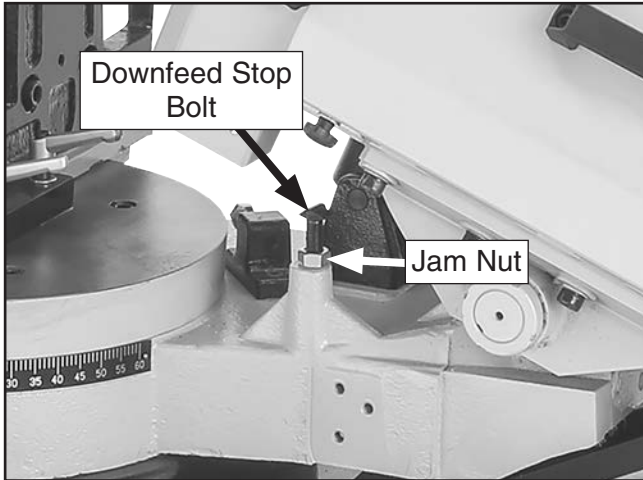

Figure 95. Location of downfeed stop bolt and jam nut.

- Tighten jam nut against swivel base without turning downfeed stop bolt to secure.
- Loosen (2) cap screws shown in **Figure 96**, then adjust limit switch until rear pivot bracket contacts limit switch.

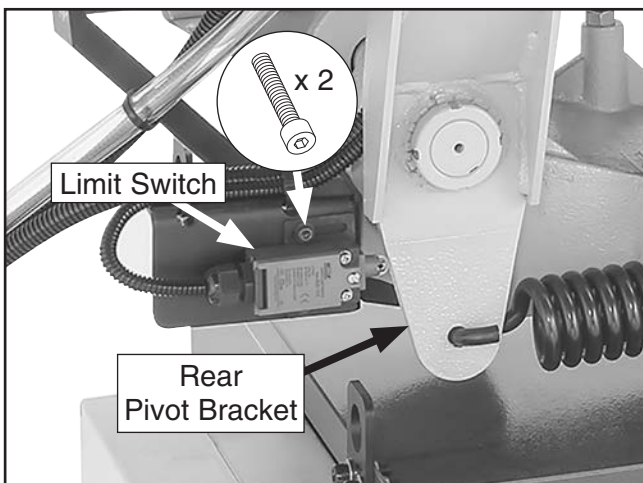

Figure 96. Location of limit switch adjustment components.

- Tighten cap screws.

Adjusting Angle Stops

The swivel base is equipped with three angle stops to provide quick adjustments. If cuts made using these stops are not sufficiently accurate, the stops will need to be adjusted.

Tools Needed	Qty
Squares 90°, 60°	1 Ea.
Open-End Wrenches 17mm	2

Setting Swivel Stop

- DISCONNECT MACHINE FROM POWER!
- Raise headstock all the way, then use feed control dial to keep it from lowering.
- Adjust headstock angle right about 5°, engage swivel stop, then rotate headstock to the left until turret just contacts stop bolt.
- Place 90° square against fixed vise jaw and blade, as shown in **Figure 97**. Square should fit snugly against fixed jaw and blade.

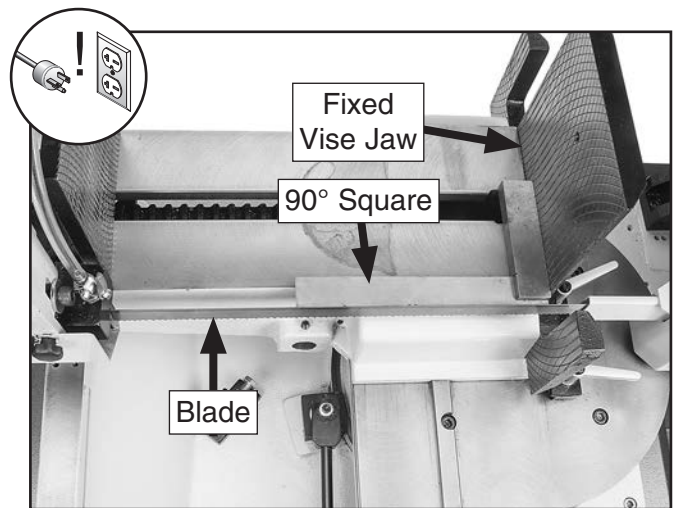

Figure 97. Example of testing blade-to-vise squareness.

— If square fits snugly against fixed jaw and blade, no adjustment is necessary.



- If square *does not* fit snugly against fixed jaw and blade, disengage swivel stop, then loosen jam nut shown in **Figure 98**. Thread stop bolt in or out as necessary, then engage swivel stop.

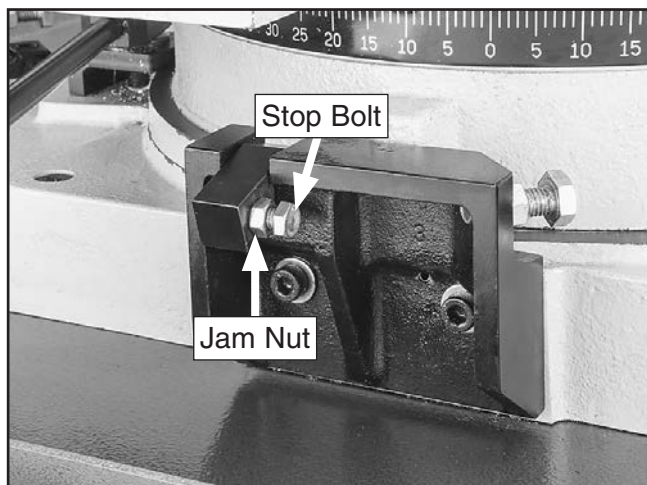

Figure 98. Example of swivel stop bolt and jam nut.

Setting 60° Stops

1. DISCONNECT MACHINE FROM POWER!
2. Raise headstock all the way.
3. Adjust headstock angle left or right until base contacts left or right 60° stop bolt (see **Figure 99**).

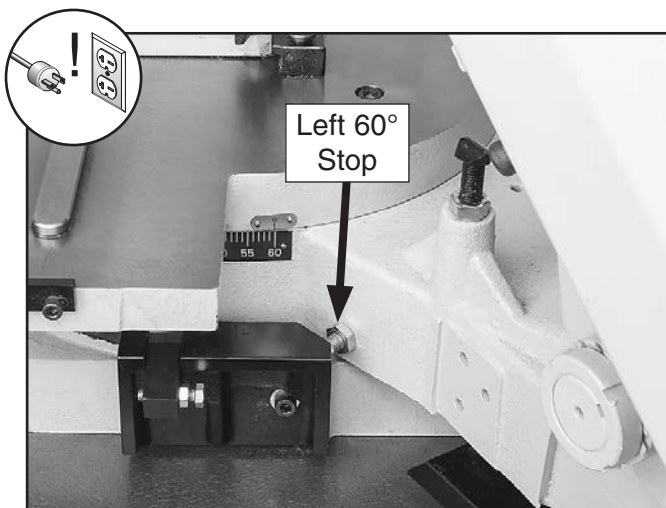

Figure 99. Example of 60° stop bolt contacting base (left 60° stop shown).

4. Move vise to opposite side of track than headstock was swiveled in **Step 3**.

5. Lower headstock all the way.
6. Place 60° square between outer fixed jaw and blade, as shown in **Figure 100**. Square should fit snugly against outer fixed jaw and blade.

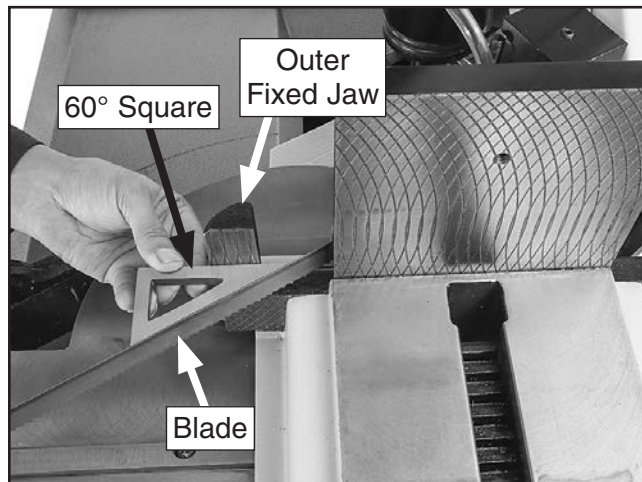

Figure 100. Example of using 60° square to check 60° stop (left 60° stop check shown).

- If square fits snugly against outer fixed jaw and blade, no adjustment is necessary.

- If square *does not* fit snugly against outer fixed jaw and blade, loosen jam nut on 60° stop (see **Figure 101**). Thread stop bolt in or out as necessary until square fits snugly against outer fixed jaw and blade while base contacts stop bolt.

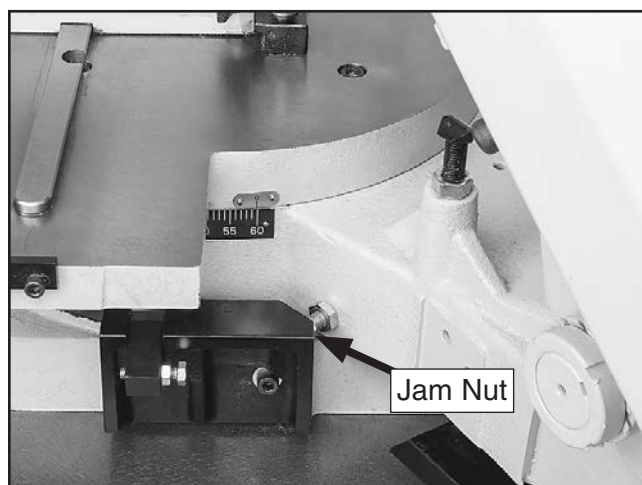

Figure 101. Location of 60° stop bolt jam nut (left 60° stop shown).



Tensioning/ Replacing V-Belt

To ensure optimum power transmission from the motor to the bandsaw blade, the V-belt must be in good condition (free from cracks, fraying, and wear) and properly tensioned. After the first 16 hours of belt life, re-tension the belt, as it will stretch and seat during this time.

Tools Needed	Qty
Phillips Head Screwdriver #2	1
Open-End Wrench 19mm.....	1
Replacement V-Belt (P0592462)	As Needed

To tension/replace V-belt:

1. DISCONNECT MACHINE FROM POWER!
2. Remove (2) Phillips head screws shown in **Figure 102** to remove variable-speed belt covers.
3. Remove (4) Phillips head screws shown in **Figure 102** to remove belt cover.

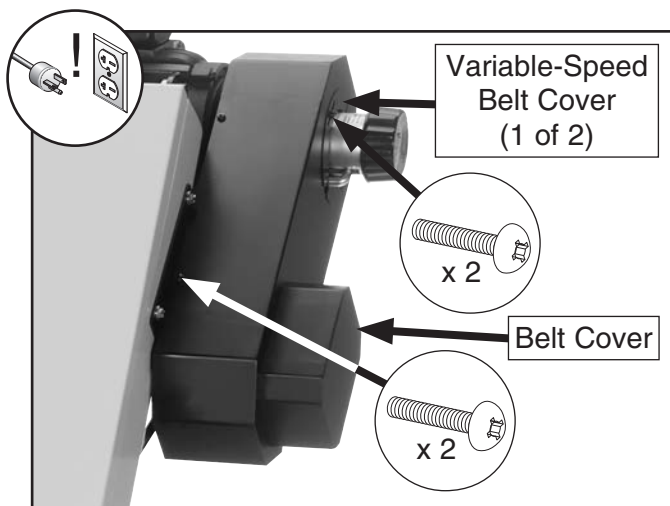

Figure 102. Location of variable-speed belt covers, belt cover, and screws.

4. Adjust hex nuts shown in **Figure 103** until there is approximately $\frac{1}{4}$ " deflection when V-belt is pushed with moderate pressure, as shown in **Figure 104**.

— If V-belt is cracked, frayed, or worn, adjust hex nuts until V-belt can be removed from pulleys, then replace belt before performing above adjustment.

Note: Make sure ribs of belt are seated in pulley grooves.

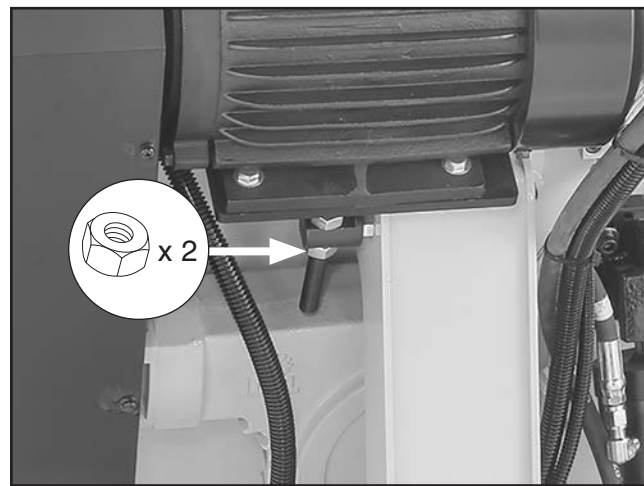

Figure 103. Location of belt tension hex nuts.

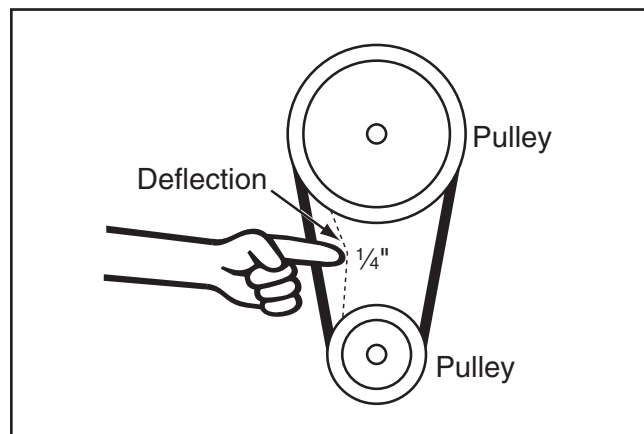

Figure 104. Checking belt deflection.

5. Install belt cover.
6. Install variable-speed belt covers.



SECTION 8: WIRING

These pages are current at the time of printing. However, in the spirit of improvement, we may make changes to the electrical systems of future machines. Compare the manufacture date of your machine to the one stated in this manual, and study this section carefully.

If there are differences between your machine and what is shown in this section, call Technical Support at (570) 546-9663 for assistance BEFORE making any changes to the wiring on your machine. An updated wiring diagram may be available. **Note:** *Please gather the serial number and manufacture date of your machine before calling. This information can be found on the main machine label.*

WARNING

Wiring Safety Instructions

SHOCK HAZARD. Working on wiring that is connected to a power source is extremely dangerous. Touching electrified parts will result in personal injury including but not limited to severe burns, electrocution, or death. Disconnect the power from the machine before servicing electrical components!

MODIFICATIONS. Modifying the wiring beyond what is shown in the diagram may lead to unpredictable results, including serious injury or fire. This includes the installation of unapproved after-market parts.

WIRE CONNECTIONS. All connections must be tight to prevent wires from loosening during machine operation. Double-check all wires disconnected or connected during any wiring task to ensure tight connections.

CIRCUIT REQUIREMENTS. You MUST follow the requirements at the beginning of this manual when connecting your machine to a power source.

WIRE/COMPONENT DAMAGE. Damaged wires or components increase the risk of serious personal injury, fire, or machine damage. If you notice that any wires or components are damaged while performing a wiring task, replace those wires or components.

MOTOR WIRING. The motor wiring shown in these diagrams is current at the time of printing but may not match your machine. If you find this to be the case, use the wiring diagram inside the motor junction box.















CAPACITORS/INVERTERS. Some capacitors and power inverters store an electrical charge for up to 10 minutes after being disconnected from the power source. To reduce the risk of being shocked, wait at least this long before working on capacitors.

EXPERIENCING DIFFICULTIES. If you are experiencing difficulties understanding the information included in this section, contact our Technical Support at (570) 546-9663.

NOTICE

The photos and diagrams included in this section are best viewed in color. You can view these pages in color at www.grizzly.com.

COLOR KEY

BLACK 	BLUE 	YELLOW 	LIGHT BLUE 
WHITE 	BROWN 	YELLOW GREEN 	BLUE WHITE 
GREEN 	GRAY 	PURPLE 	TURQUOISE 
RED 	ORANGE 	PINK 	



Wiring Diagram

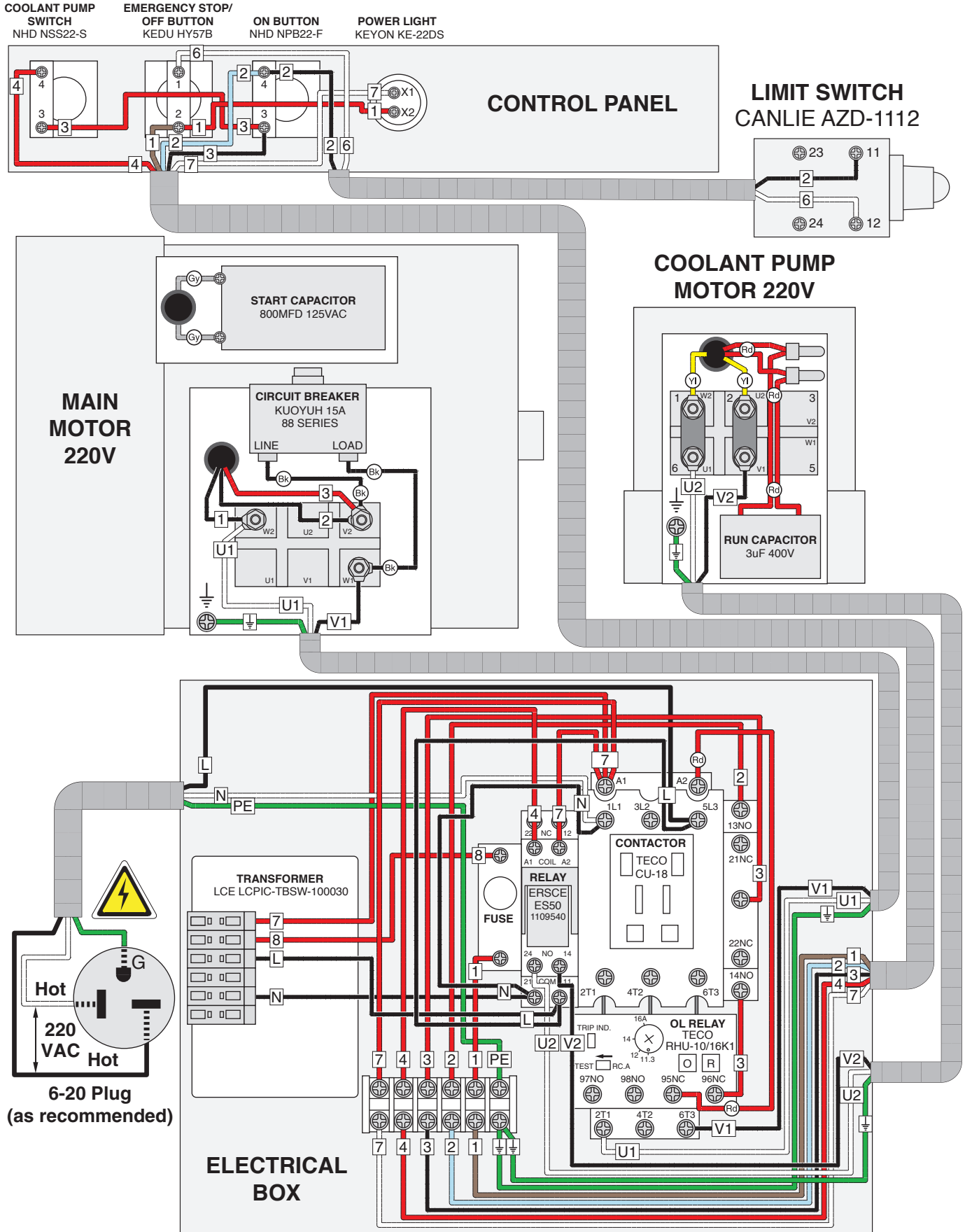

Electrical Component Photos

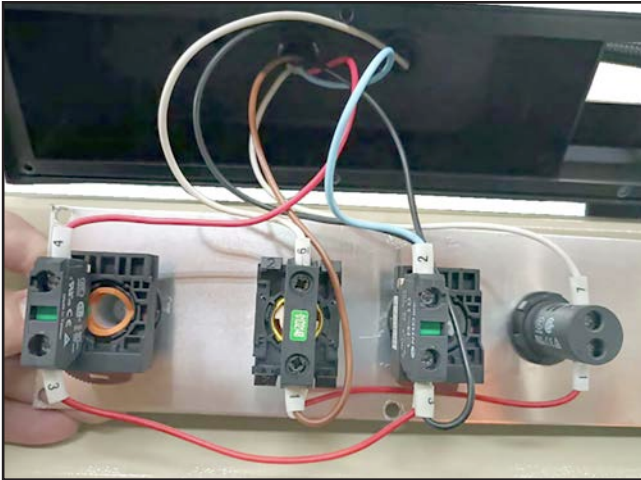

Figure 105. Control panel wiring.

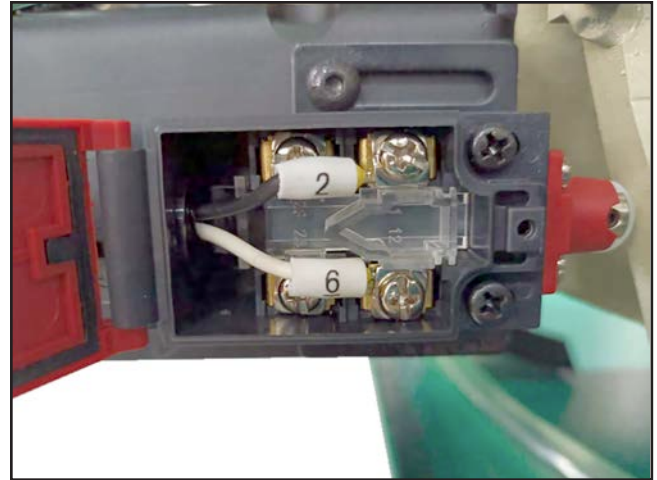

Figure 108. Limit switch wiring.

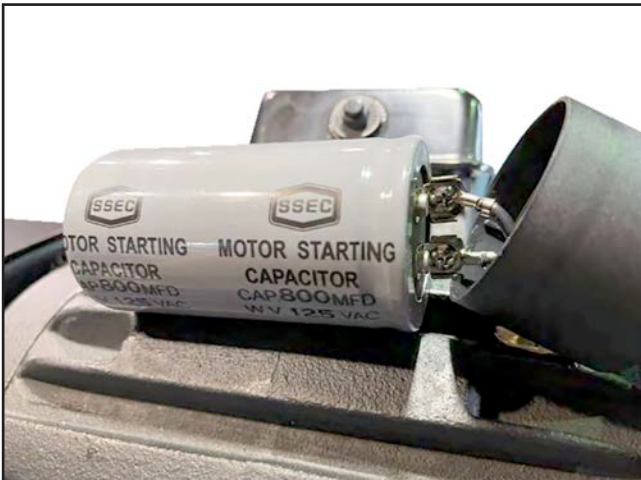

Figure 106. Start capacitor wiring.

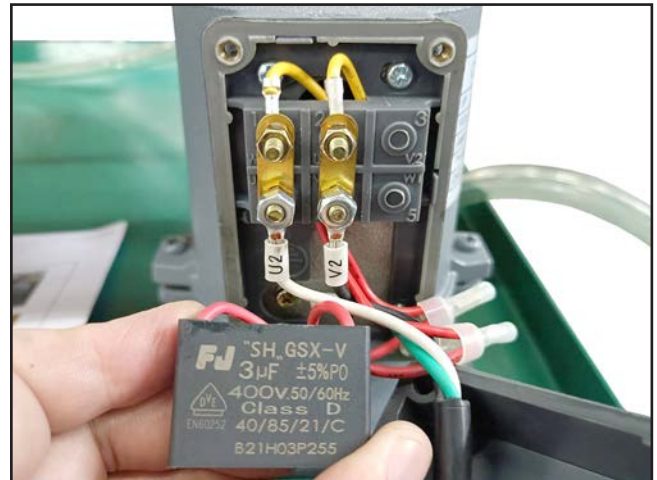

Figure 109. Pump motor wiring.



Figure 107. Motor junction box wiring.



Electrical Component Photos (Cont.)

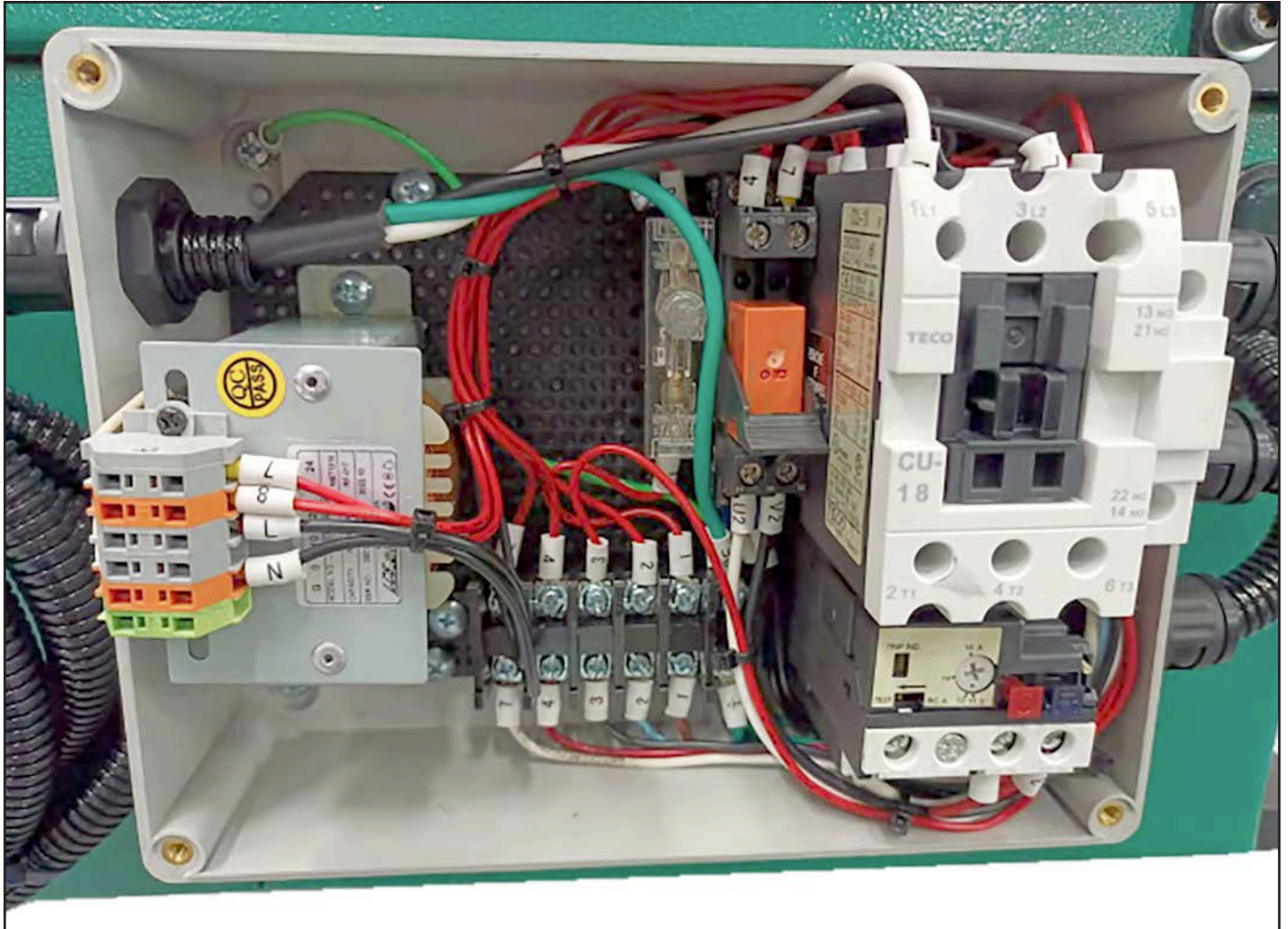
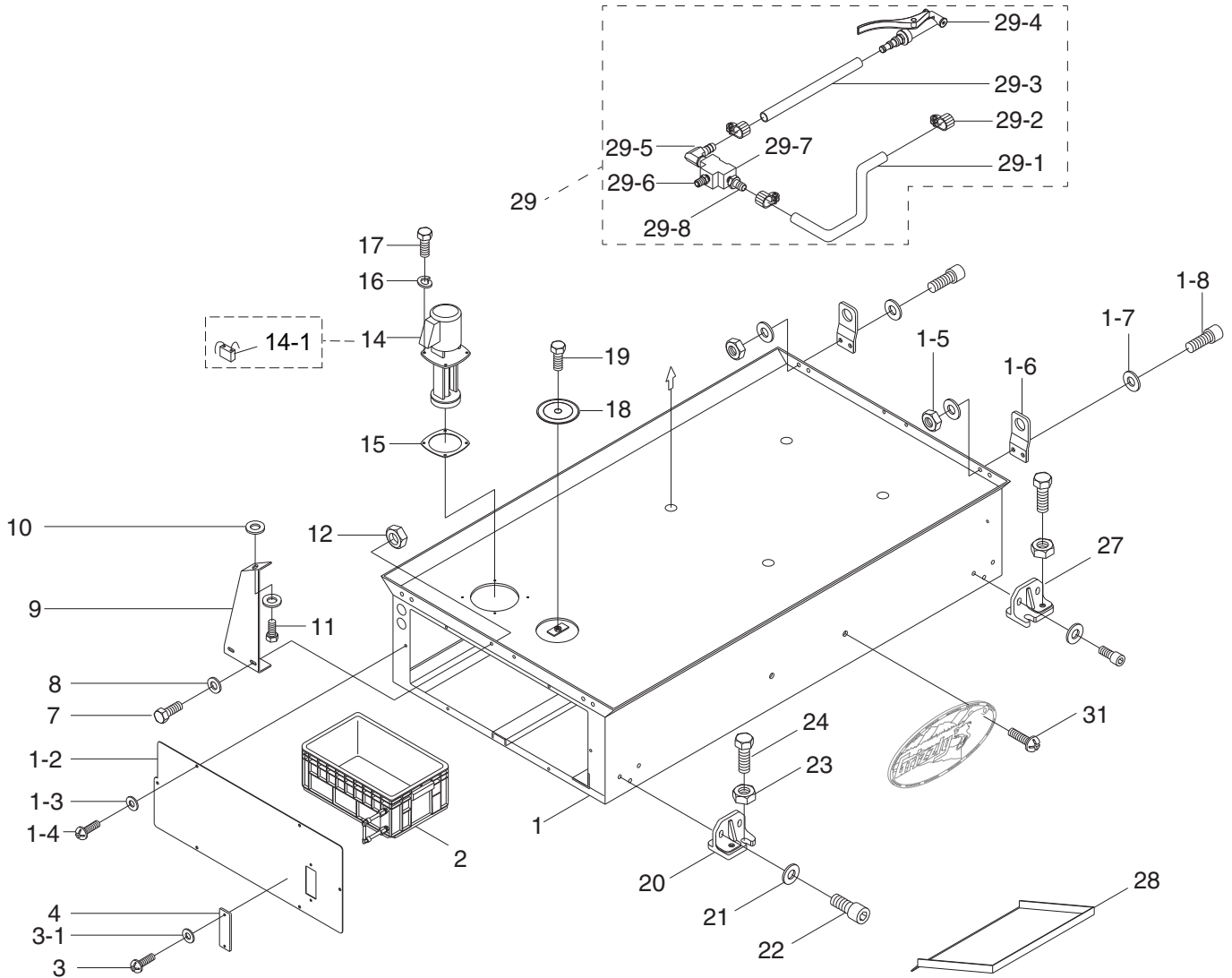

Figure 110. Electrical box wiring.

SECTION 9: PARTS

We do our best to stock replacement parts when possible, but we cannot guarantee that all parts shown are available for purchase. Call (800) 523-4777 or visit www.grizzly.com/parts to check for availability.

Base



Base Parts List

REF	PART #	DESCRIPTION
1	P0592001	STAND
1-2	P0592001-2	STAND COVER
1-3	P0592001-3	FLAT WASHER 6MM
1-4	P0592001-4	PHLP HD SCR M6-1 X 10
1-5	P0592001-5	HEX NUT M8-1.25
1-6	P0592001-6	HANGER PLATE
1-7	P0592001-7	FENDER WASHER 18MM
1-8	P0592001-8	CAP SCREW M8-1.25 X 25
2	P0592002	COOLANT RESERVOIR
3	P0592003	PHLP HD SCR M5-.8 X 10
3-1	P0592003-1	FLAT WASHER 5MM
4	P0592004	ACRYLIC PLATE
7	P0592007	HEX BOLT M6-1 X 15
8	P0592008	FLAT WASHER 6MM
9	P0592009	FIXED PLATE
10	P0592010	FLAT WASHER 8MM
11	P0592011	HEX BOLT M8-1.25 X 20
12	P0592012	HEX NUT M8-1.25
14	P0592014	COOLANT PUMP 1/8HP 220V 1PH
14-1	P0592014-1	R CAPACITOR 3M 400V
15	P0592015	RUBBER GASKET

REF	PART #	DESCRIPTION
16	P0592016	LOCK WASHER 6MM
17	P0592017	HEX BOLT M6-1 X 15
18	P0592018	FILTER SCREEN
19	P0592019	HEX BOLT M6-1 X 10
20	P0592020	LOCATING FOOT LEFT
21	P0592021	FLAT WASHER 8MM
22	P0592022	CAP SCREW M8-1.25 X 20
23	P0592023	HEX NUT M12-1.75
24	P0592024	HEX BOLT M12-1.75 X 50
27	P0592027	LOCATING FOOT RIGHT
28	P0592028	SPLASH GUARD
29	P0592029	SPRAY ASSEMBLY
29-1	P0592029-1	HOSE
29-2	P0592029-2	HOSE CLAMP
29-3	P0592029-3	HOSE
29-4	P0592029-4	SPRAY GUN
29-5	P0592029-5	MICRO CONTROL BLOCK
29-6	P0592029-6	STRAIGHT CONNECTOR
29-7	P0592029-7	CONNECTOR 3-WAY
29-8	P0592029-8	STRAIGHT CONNECTOR
31	P0592031	PHLP HD SCR M5-.8 X 12



Swivel Base

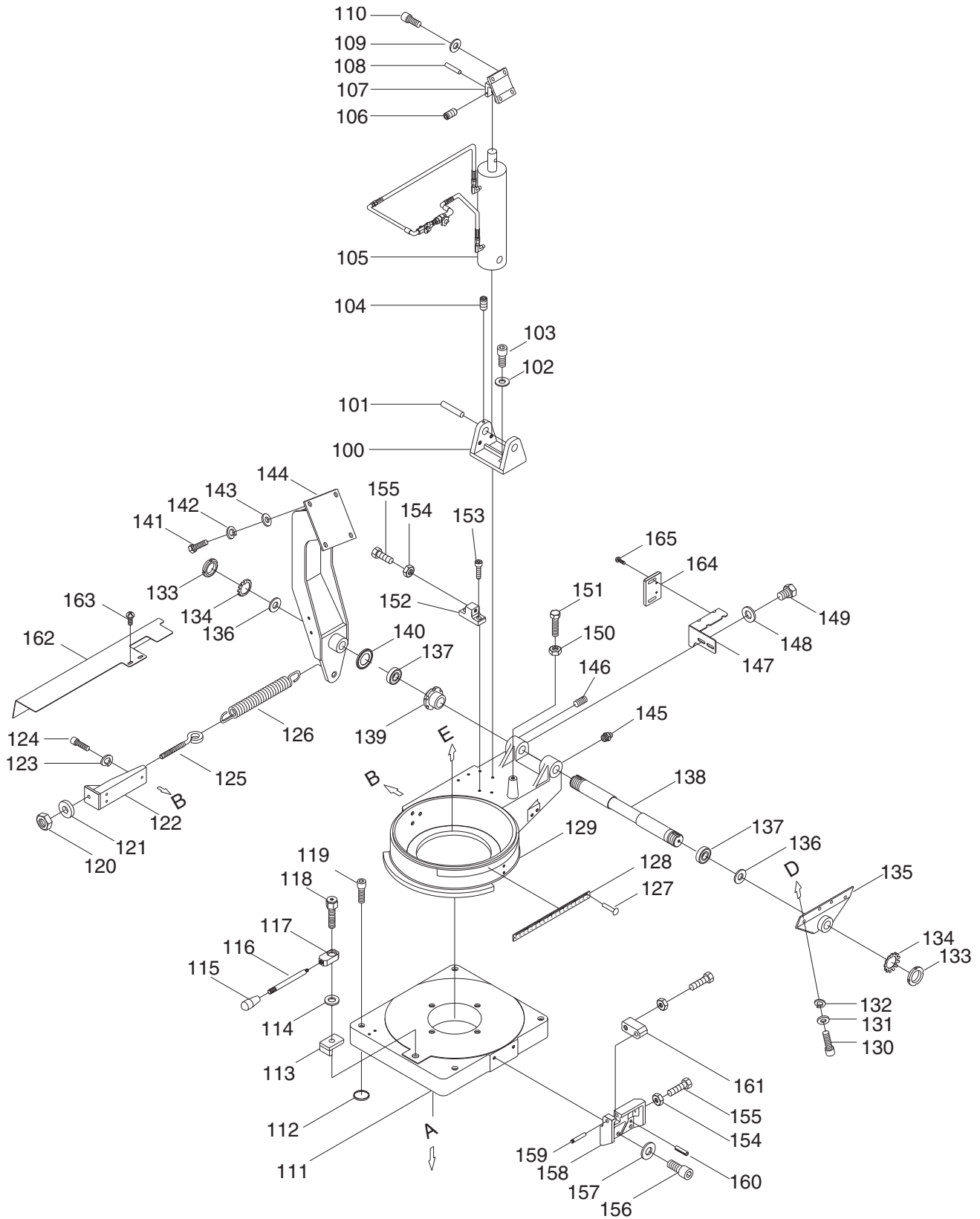

Swivel Base Parts List

REF	PART #	DESCRIPTION
100	P0592100	CYLINDER LOWER SUPPORT
101	P0592101	PIVOT PIN
102	P0592102	LOCK WASHER 8MM
103	P0592103	HEX BOLT M8-1.25 X 20
104	P0592104	SET SCREW M6-1 X 10
105	P0592105	CYLINDER ASSY
106	P0592106	SET SCREW M6-1 X 10
107	P0592107	CYLINDER UPPER SUPPORT
108	P0592108	PIVOT PIN
109	P0592109	FLAT WASHER 8MM
110	P0592110	CAP SCREW M8-1.25 X 20
111	P0592111	SWIVEL ARM BASE
112	P0592112	O-RING 11.8 X 2.4 P12
113	P0592113	SWIVEL ARM BRACKET
114	P0592114	FLAT WASHER 12MM
115	P0592115	HANDLE
116	P0592116	SCREW ROD
117	P0592117	HUB
118	P0592118	PIVOT BOLT
119	P0592119	CAP SCREW M10-1.5 X 35
120	P0592120	HEX NUT M12-1.75
121	P0592121	FLAT WASHER 12MM
122	P0592122	FEED SUPPORT
123	P0592123	LOCK WASHER 8MM
124	P0592124	CAP SCREW M8-1.25 X 25
125	P0592125	EYE BOLT
126	P0592126	EXTENSION SPRING
127	P0592127	RIVET 2 X 5MM NAMEPLATE, STEEL
128	P0592128	DEGREE SCALE
129	P0592129	SWIVEL BASE UPPER
130	P0592130	CAP SCREW M10-1.5 X 25
131	P0592131	FLAT WASHER 10MM
132	P0592132	LOCK WASHER 10MM

REF	PART #	DESCRIPTION
133	P0592133	SPANNER NUT
134	P0592134	EXT TOOTH WASHER
135	P0592135	BRACKET
136	P0592136	GAP RING
137	P0592137	TAPER ROLLER BEARING 32007
138	P0592138	PIVOT SHAFT
139	P0592139	RING
140	P0592140	CHIP COVER
141	P0592141	HEX BOLT M10-1.5 X 30
142	P0592142	LOCK WASHER 10MM
143	P0592143	FLAT WASHER 10MM
144	P0592144	PIVOT BRACKET REAR
145	P0592145	GREASE FITTING
146	P0592146	SET SCREW M6-1 X 10
147	P0592147	SWITCH BRACKET
148	P0592148	FLAT WASHER 8MM
149	P0592149	HEX BOLT M8-1.25 X 10
150	P0592150	HEX NUT M12-1.75
151	P0592151	HEX BOLT M12-1.75 X 50
152	P0592152	ANGLE MARGIN
153	P0592153	CAP SCREW M8-1.25 X 20
154	P0592154	HEX NUT M10-1.5
155	P0592155	HEX BOLT M10-1.5 X 40
156	P0592156	CAP SCREW M8-1.25 X 25
157	P0592157	FLAT WASHER 8MM
158	P0592158	ANGLE POSITION
159	P0592159	BEARING PIN
160	P0592160	ROLL PIN 5 X 20
161	P0592161	LOCATING BLOCK
162	P0592162	SPRING COVER
163	P0592163	PHLP HD SCR M6-1 X 6
164	P0592164	SWITCH ADJUSTING BRACKET
165	P0592165	HEX BOLT M5-.8 x 10



Vise

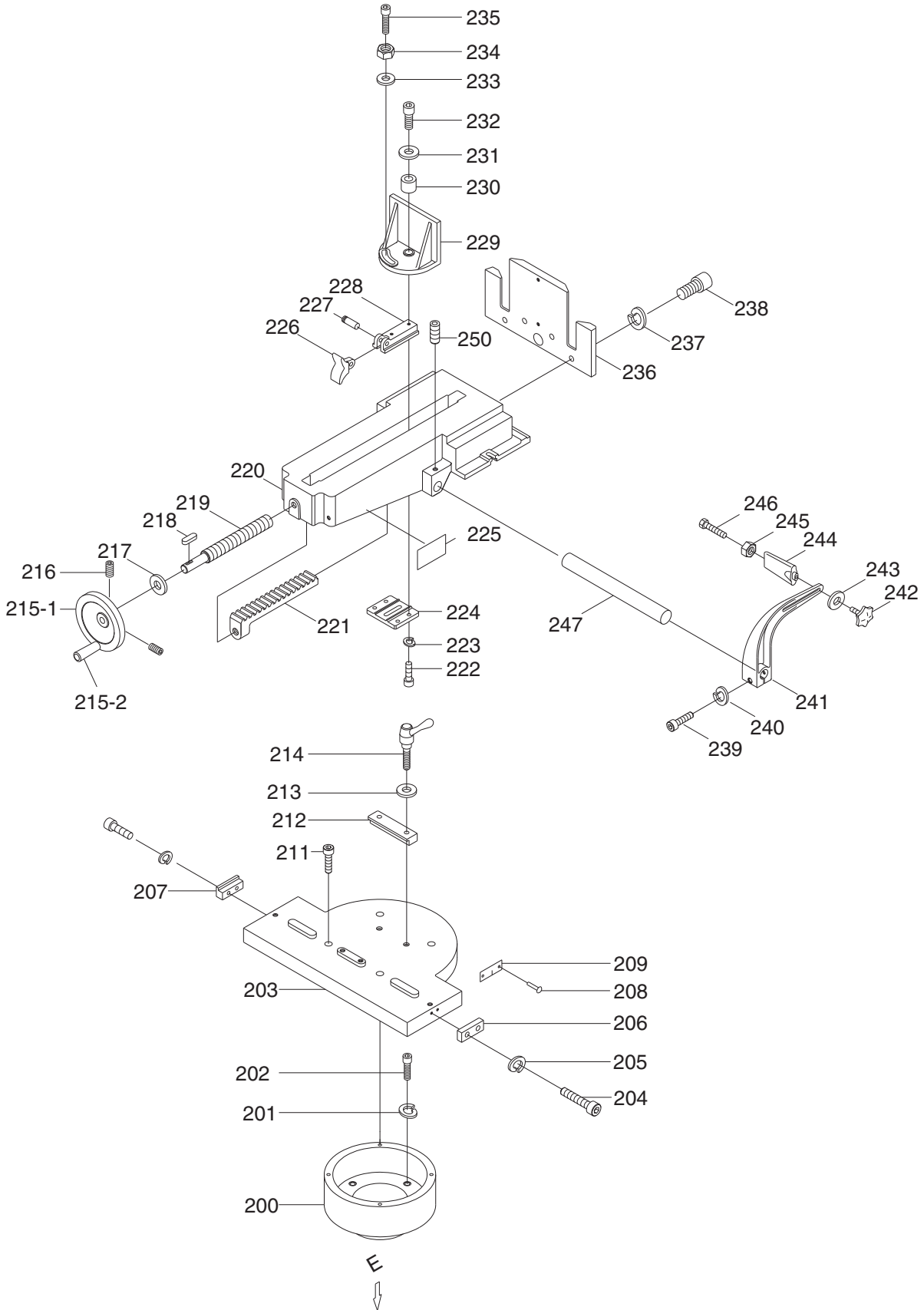

Vise Parts List

REF	PART #	DESCRIPTION
200	P0592200	FIXED SHAFT
201	P0592201	LOCK WASHER 10MM
202	P0592202	CAP SCREW M10-1.5 X 35
203	P0592203	SLIDE BASE
204	P0592204	CAP SCREW M6-1 X 20
205	P0592205	LOCK WASHER 6MM
206	P0592206	LIMIT BLOCK 2-WAY
207	P0592207	LIMIT BLOCK 2-WAY
208	P0592208	RIVET 2 X 5
209	P0592209	SCALE
211	P0592211	CAP SCREW M10-1.5 X 30
212	P0592212	FIXED BLOCK
213	P0592213	BUSHING
214	P0592214	KNOB M10-1.5 X 40
215-1	P0592215-1	HANDWHEEL
215-2	P0592215-2	HANDWHEEL HANDLE
216	P0592216	SET SCREW M6-1 X 10
217	P0592217	FLAT WASHER 13MM
218	P0592218	KEY 5 X 5 X 15
219	P0592219	LEADSCREW
220	P0592220	VICE BASE
221	P0592221	RACK
222	P0592222	CAP SCREW M8-1.25 X 25
223	P0592223	LOCK WASHER 8MM
224	P0592224	RACK SUPPORT

REF	PART #	DESCRIPTION
225	P0592225	NAME PLATE
226	P0592226	RACK HOOK
227	P0592227	SOLID PIN
228	P0592228	BRACKET
229	P0592229	VICE JAW FRONT
230	P0592230	BUSHING
231	P0592231	FLAT WASHER 10MM
232	P0592232	CAP SCREW M10-1.5 X 35
233	P0592233	FLAT WASHER 10MM
234	P0592234	HEX NUT M10-1.5
235	P0592235	CAP SCREW M10-1.5 X 40
236	P0592236	VICE JAW BRACKET REAR
237	P0592237	LOCK WASHER 12MM
238	P0592238	CAP SCREW M12-1.75 X 45
239	P0592239	CAP SCREW M8-1.25 X 45
240	P0592240	LOCK WASHER 8MM
241	P0592241	STOP BLOCK SUPPORT
242	P0592242	WORK STOP KNOB
243	P0592243	FLAT WASHER 6MM
244	P0592244	WORK STOP
245	P0592245	HEX NUT M10-1.5
246	P0592246	HEX BOLT M10-1.5 X 30
247	P0592247	DISTANCE SET ROD
250	P0592250	SET SCREW M8-1.25 X 20



Headstock

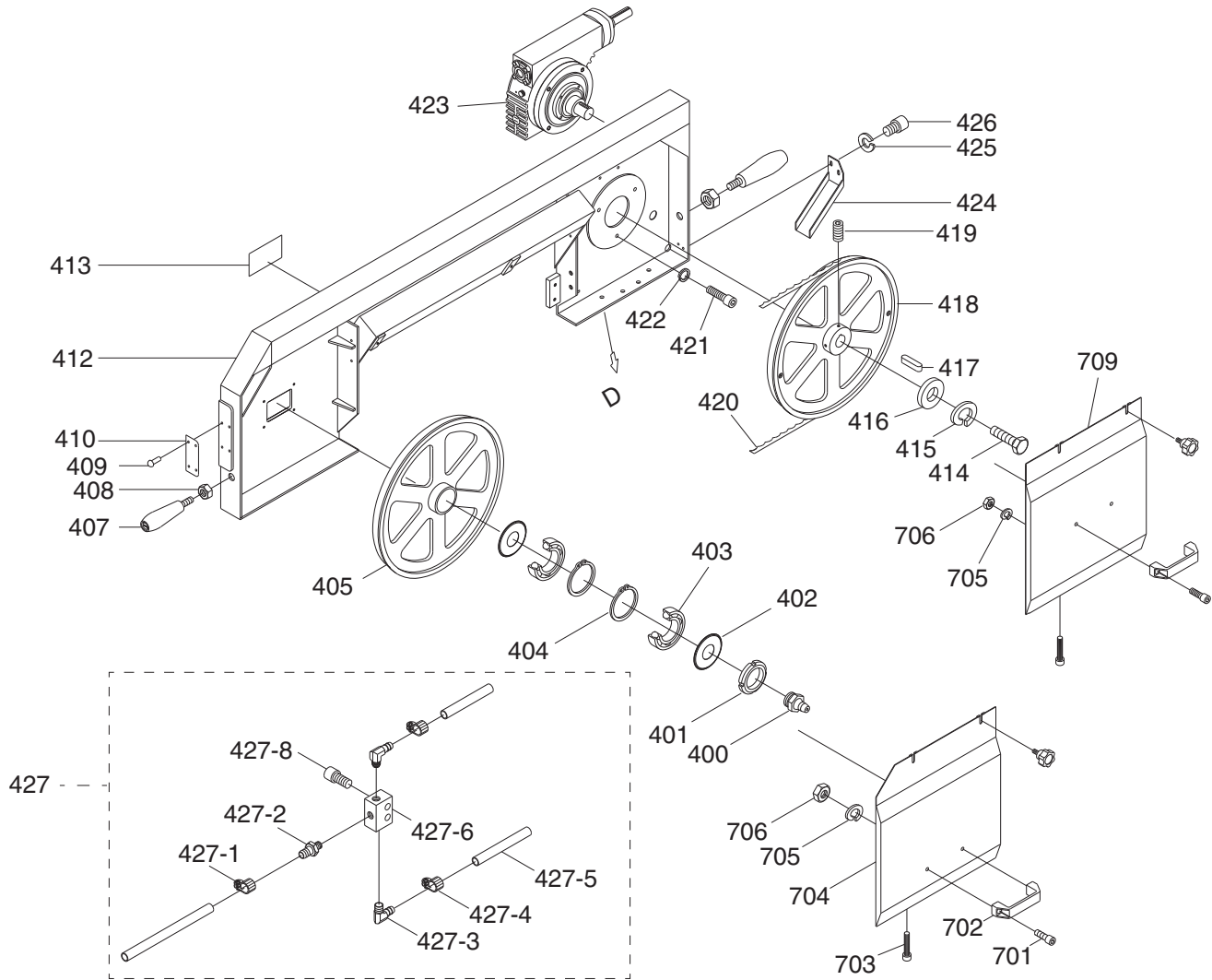

REF	PART #	DESCRIPTION
400	P0592400	GREASE FITTING
401	P0592401	SPANNER NUT
402	P0592402	COVER
403	P0592403	TAPERED ROLLER BEARING 30205
404	P0592404	INT RETAINING RING 52MM
405	P0592405	IDLER WHEEL
407	P0592407	HANDLE
408	P0592408	HEX NUT 3/8-16
409	P0592409	RIVET 2 X 5
410	P0592410	LOOSEN TIGHTEN LABEL
412	P0592412	HEADSTOCK FRAME
413	P0592413	TENSION GAUGE PLATE
414	P0592414	HEX BOLT M10-1.5 X 25
415	P0592415	LOCK WASHER 10MM
416	P0592416	FLAT WASHER 10MM
417	P0592417	KEY 7 X 7 X 29
418	P0592418	DRIVE WHEEL
419	P0592419	SET SCREW M8-1.25 X 6
420	P0592420	BLADE 132 X 1 X .032" 6/10TPI
421	P0592421	CAP SCREW M10-1.5 X 20

REF	PART #	DESCRIPTION
422	P0592422	LOCK WASHER 10MM
423	P0592423	GEAR BOX ASSY
424	P0592424	SPLASH BOARD
425	P0592425	FLAT WASHER 6MM
426	P0592426	CAP SCREW M6-1 X 10
427	P0592427	VALVE ASSY 3-WAY
427-1	P0592427-1	HOSE CLAMP
427-2	P0592427-2	STRAIGHT CONNECTOR
427-3	P0592427-3	MICRO CONTROL BLOCK
427-4	P0592427-4	HOSE CLAMP
427-5	P0592427-5	NET TUBE
427-6	P0592427-6	VALVE 3-WAY
427-8	P0592427-8	CAP SCREW M6-1 X 30
701	P0592701	CAP SCREW M8-1.25 X 15
702	P0592702	HANDLE
703	P0592703	CAP SCREW M6-1 X 10
704	P0592704	BLADE BACK COVER
705	P0592705	LOCK WASHER 8MM
706	P0592706	HEX NUT M8-1.25
709	P0592709	BLADE BACK COVER



Blade Tension & Motor

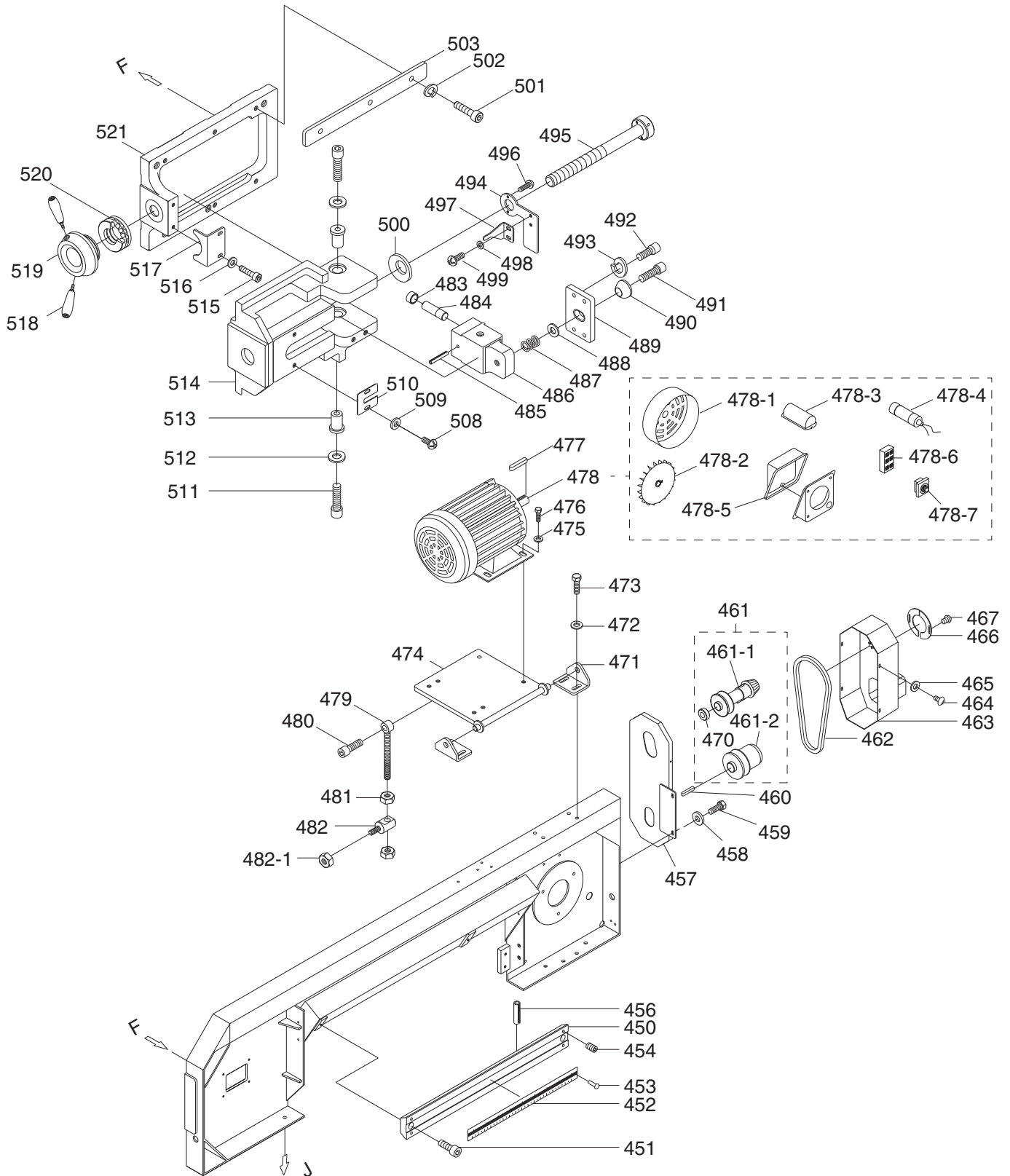

Blade Tension & Motor Parts List

REF	PART #	DESCRIPTION
450	P0592450	COLUMN
451	P0592451	CAP SCREW M12-1.75 X 20
452	P0592452	SCALE
453	P0592453	RIVET 2 X 5MM NAMEPLATE, STEEL
454	P0592454	SET SCREW M8-1.25 X 20
456	P0592456	ROLL PIN 6 X 30
457	P0592457	PULLEY LOWER COVER
458	P0592458	FLAT WASHER 6MM
459	P0592459	HEX BOLT M6-1 X 10
460	P0592460	KEY 7 X 7 X 29
461	P0592461	VARIABLE SPEED PULLEY ASSY
461-1	P0592461-1	VARIABLE SPEED PULLEY
461-2	P0592461-2	SPINDLE PULLEY
462	P0592462	COGGED V-BELT 1422V-360
463	P0592463	MOTOR PULLEY COVER
464	P0592464	PHLP HD SCR M5-.8 X 10
465	P0592465	FLAT WASHER 5MM
466	P0592466	COVER
467	P0592467	PHLP HD SCR M5-.8 X 6
470	P0592470	WASHER RING
471	P0592471	MOTOR BRACKET
472	P0592472	FLAT WASHER 6MM
473	P0592473	HEX BOLT M6-1 X 20
474	P0592474	MOTOR PLATE
475	P0592475	FLAT WASHER 8MM
476	P0592476	HEX BOLT M8-1.25 X 15
477	P0592477	KEY 7 X 7 X 35
478	P0592478	MOTOR 2HP 220V 1-PH
478-1	P0592478-1	MOTOR COVER
478-2	P0592478-2	MOTOR FAN
478-3	P0592478-3	CAPACITOR COVER
478-4	P0592478-4	S CAPACITOR 800M 125V 1-3/4 X 3-3/8
478-5	P0592478-5	JUNCTION BOX
478-6	P0592478-6	MOTOR TERMINAL BLOCK 6P
478-7	P0592478-7	CIRCUIT BREAKER 15A KUOYUH 88
479	P0592479	SHAFT
480	P0592480	CAP SCREW M10-1.5 X 60
481	P0592481	HEX NUT M12-1.75

REF	PART #	DESCRIPTION
482	P0592482	SHAFT
482-1	P0592482-1	HEX NUT M10-1.5
483	P0592483	BUSHING
484	P0592484	SHAFT
485	P0592485	ROLL PIN 6 X 30
486	P0592486	BLADE ANGLE ADJUSTING BRACKET
487	P0592487	COMPRESSION SPRING
488	P0592488	FLAT WASHER 10MM
489	P0592489	PLATE
490	P0592490	BEVEL BUSHING
491	P0592491	CAP SCREW M10-1.5 X 65
492	P0592492	CAP SCREW M6-1 X 30
493	P0592493	LOCK WASHER 6MM
494	P0592494	PLATE
495	P0592495	LEADSCREW
496	P0592496	PHLP HD SCR M4-.7 X 20
497	P0592497	SCALE
498	P0592498	FLAT WASHER 4MM
499	P0592499	PHLP HD SCR M4-.7 X 10
500	P0592500	DISC SPRING
501	P0592501	CAP SCREW M8-1.25 X 40
502	P0592502	LOCK WASHER 8MM
503	P0592503	GIB
508	P0592508	PHLP HD SCR M5-.8 X 8
509	P0592509	FLAT WASHER 5MM
510	P0592510	TENSION PLATE
511	P0592511	CAP SCREW M6-1 X 25
512	P0592512	FLAT WASHER 6MM
513	P0592513	SHAFT BUSHING
514	P0592514	BLADE TENSION SLIDING PLATE
515	P0592515	PHLP HD SCR M5-.8 X 10
516	P0592516	FLAT WASHER 5MM
517	P0592517	BRACKET
518	P0592518	HANDLE
519	P0592519	HANDLE BODY
520	P0592520	THRUST BEARING 51204
521	P0592521	ANCHOR BLOCK



Blade Guides

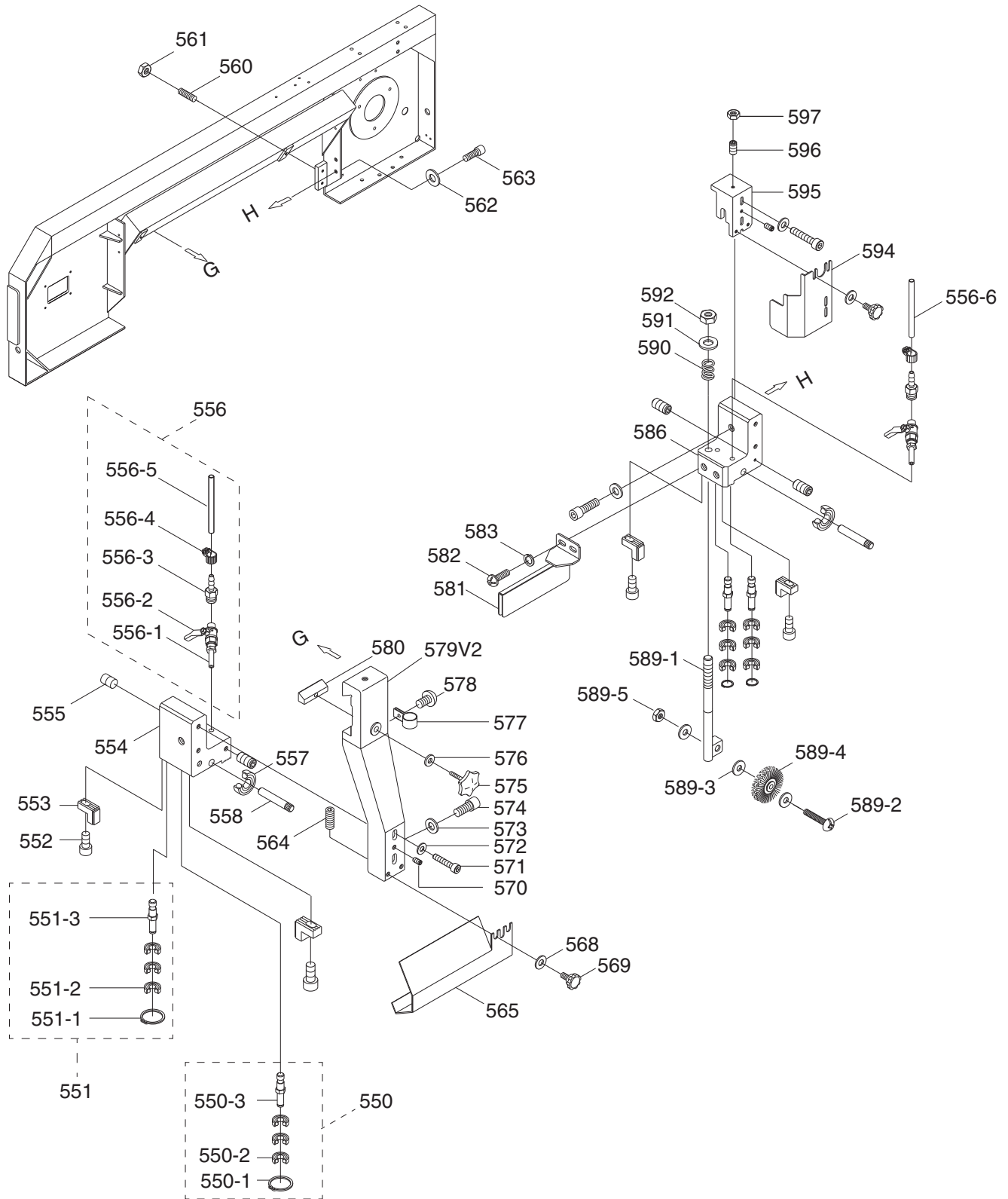

Blade Guides Parts List

REF	PART #	DESCRIPTION
550	P0592550	BEARING SHAFT ASSY
550-1	P0592550-1	EXT RETAINING RING 25MM
550-2	P0592550-2	BALL BEARING 609ZZ
550-3	P0592550-3	BEARING SHAFT
551	P0592551	ECCENTRIC SHAFT ASSY
551-1	P0592551-1	INT RETAINING RING 10MM
551-2	P0592551-2	BALL BEARING 609ZZ
551-3	P0592551-3	ECCENTRIC SHAFT
552	P0592552	CAP SCREW M6-1 X 20
553	P0592553	CARBIDE GUIDE
554	P0592554	BEARING BRACKET LEFT
555	P0592555	SET SCREW M5-.8 X 10
556	P0592556	VALVE ASSY
556-1	P0592556-1	COPPER TUBE
556-2	P0592556-2	VALVE
556-3	P0592556-3	STRAIGHT CONNECTOR
556-4	P0592556-4	HOSE CLAMP
556-5	P0592556-5	NET TUBE 1/4 X 143CM
556-6	P0592556-6	NET TUBE 1/4 X 63CM
557	P0592557	BALL BEARING 609ZZ
558	P0592558	BEARING PIN
560	P0592560	SET SCREW M8-1.25 X 30
561	P0592561	HEX NUT M8-1.25
562	P0592562	FLAT WASHER 8MM
563	P0592563	CAP SCREW M8-1.25 X 20
564	P0592564	SET SCREW M6-1 X 30
565	P0592565	BLADE GUARD FRONT
568	P0592568	FLAT WASHER 6MM

REF	PART #	DESCRIPTION
569	P0592569	KNOB M6-1 X 10
570	P0592570	SET SCREW M6-1 X 10
571	P0592571	CAP SCREW M8-1.25 X 25
572	P0592572	FLAT WASHER 8MM
573	P0592573	FLAT WASHER 10MM
574	P0592574	CAP SCREW M10-1.5 X 40
575	P0592575	BLADE ADJUSTABLE KNOB
576	P0592576	FLAT WASHER 10MM
577	P0592577	HOSE CLAMP
578	P0592578	PHLP HD SCR M5-.8 X 10
579V2	P0592579V2	ARM LEFT BEIGE V2.01.09
580	P0592580	GIB
581	P0592581	BLADE GUARD REAR
582	P0592582	PHLP HD SCR M5-.8 X 10
583	P0592583	FLAT WASHER 5MM
586	P0592586	BLADE ADJUSTER REAR
589-1	P0592589-1	BRUSH SHAFT
589-2	P0592589-2	PHLP HD SCR M6-1 X 40
589-3	P0592589-3	FLAT WASHER 6MM
589-4	P0592589-4	BRUSH
589-5	P0592589-5	HEX NUT M6-1
590	P0592590	COMPRESSION SPRING
591	P0592591	FLAT WASHER 10MM
592	P0592592	HEX NUT M10-1.5
594	P0592594	BLADE GUARD REAR
595	P0592595	ARM RIGHT
596	P0592596	SET SCREW M8-1.25 X 25
597	P0592597	HEX NUT M8-1.25



Electrical

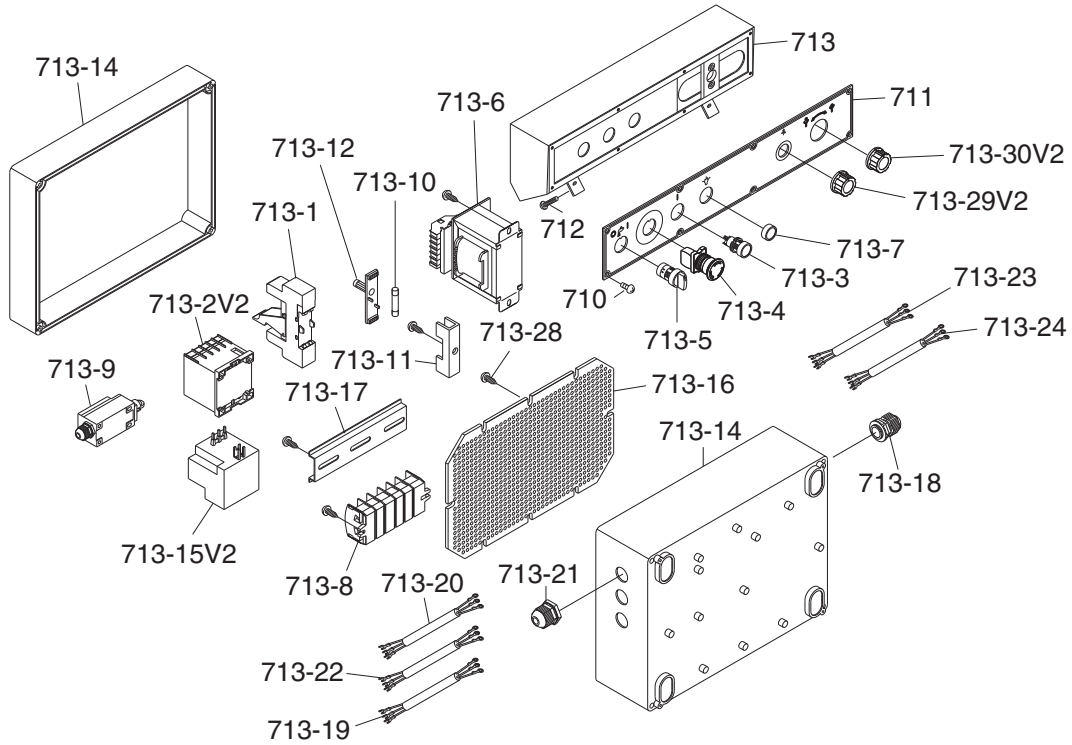

REF	PART #	DESCRIPTION
710	P0592710	PHLP HD SCR M5-.8 X 10
711	P0592711	CONTROL PLATE
712	P0592712	PHLP HD SCR M5-.8 X 12
713	P0592713	CONTROL BOX
713-1	P0592713-1	PUMP RELAY RX78625 12A 300V CE
713-2V2	P0592713-2V2	CONTACTOR TECO CU-18 24V V2.03.14
713-3	P0592713-3	ON BUTTON
713-4	P0592713-4	EMERGENCY STOP/OFF SWITCH
713-5	P0592713-5	PUMP ON/OFF SWITCH
713-6	P0592713-6	TRANSFORMER 63VA 110/220V-24V
713-7	P0592713-7	POWER INDICATOR LIGHT XB7 EV6 250V 22MM
713-8	P0592713-8	TERMINAL BLOCK
713-9	P0592713-9	LIMIT SWITCH
713-10	P0592713-10	FUSE
713-11	P0592713-11	BRACKET

REF	PART #	DESCRIPTION
713-12	P0592713-12	FUSE COVER
713-14	P0592713-14	ENCLOSURE W/COVER
713-15V2	P0592713-15V2	RELAY TECO RHU-10 11.3-16A V2.03.14
713-16	P0592713-16	PANEL
713-17	P0592713-17	BRACKET
713-18	P0592713-18	STRAIN RELIEF M14 TYPE-6 ST
713-19	P0592713-19	PUMP WIRE HARNESS
713-20	P0592713-20	MOTOR WIRE HARNESS
713-21	P0592713-21	STRAIN RELIEF
713-22	P0592713-22	CONTROL PANEL WIRE HARNESS
713-23	P0592713-23	LIMIT SWITCH WIRE HARNESS
713-24	P0592713-24	POWER WIRE HARNESS
713-28	P0592713-28	PHLP HD SCR M5-.8 X 12
713-29V2	P0592713-29V2	FEED RATE DIAL V2.12.08
713-30V2	P0592713-30V2	FEED/SPEED CONTROL DIAL V2.12.08



Labels & Cosmetics

G0592

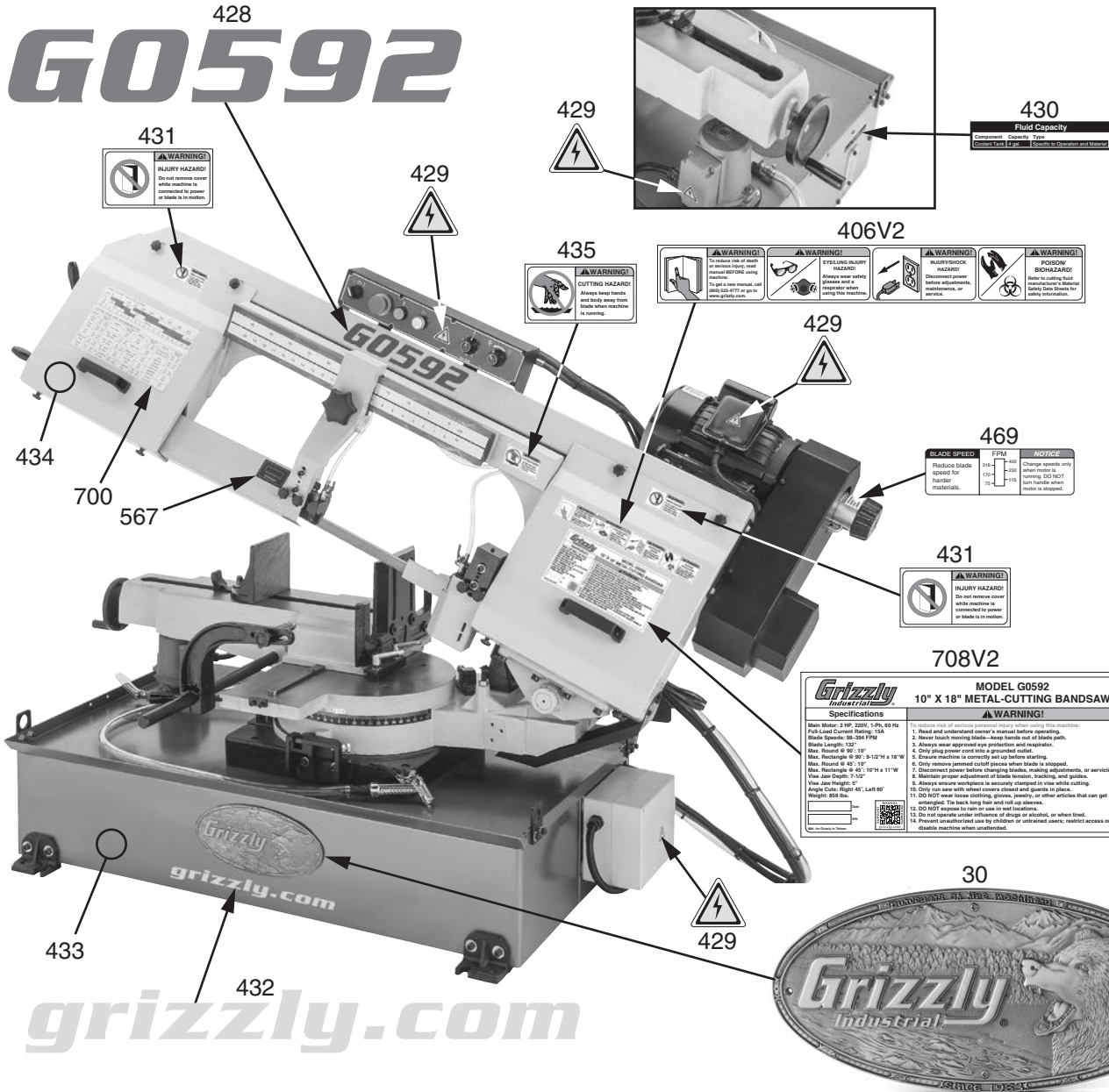

REF	PART #	DESCRIPTION
30	P0592030	GRIZZLY NAMEPLATE-LARGE
406V2	P0592406V2	COMBO WARNING LABEL V2.01.23
428	P0592428	MODEL NUMBER LABEL
429	P0592429	ELECTRICITY LABEL
430	P0592430	FLUID CAPACITY LABEL
431	P0592431	DO NOT REMOVE COVER LABEL
432	P0592432	GRIZZLY.COM LABEL

REF	PART #	DESCRIPTION
433	P0592433	TOUCH-UP PAINT, GRIZZLY GREEN
434	P0592434	TOUCH-UP PAINT, GRIZZLY BEIGE
435	P0592435	CUTTING HAZARD LABEL
469	P0592469	SPEED LABEL
567	P0592567	UPPER BLADE GUARD LABEL
700	P0592700	TOOTH SELECTION LABEL
708V2	P0592708V2	MACHINE ID LABEL V2.01.23

⚠ WARNING

Safety labels help reduce the risk of serious injury caused by machine hazards. If any label comes off or becomes unreadable, the owner of this machine **MUST** replace it in the original location before resuming operations. For replacements, contact (800) 523-4777 or www.grizzly.com.

BUY PARTS ONLINE AT GRIZZLY.COM!
Scan QR code to visit our Parts Store.



WARRANTY & RETURNS

Grizzly Industrial, Inc. warrants every product it sells for a period of **1 year** to the original purchaser from the date of purchase. This warranty does not apply to defects due directly or indirectly to misuse, abuse, negligence, accidents, repairs or alterations or lack of maintenance. This is Grizzly's sole written warranty and any and all warranties that may be implied by law, including any merchantability or fitness, for any particular purpose, are hereby limited to the duration of this written warranty. We do not warrant or represent that the merchandise complies with the provisions of any law or acts unless the manufacturer so warrants. In no event shall Grizzly's liability under this warranty exceed the purchase price paid for the product and any legal actions brought against Grizzly shall be tried in the State of Washington, County of Whatcom.

We shall in no event be liable for death, injuries to persons or property or for incidental, contingent, special, or consequential damages arising from the use of our products.

The manufacturers reserve the right to change specifications at any time because they constantly strive to achieve better quality equipment. We make every effort to ensure that our products meet high quality and durability standards and we hope you never need to use this warranty.

In the event you need to use this warranty, contact us by mail or phone and give us all the details. We will then issue you a "Return Number," which must be clearly posted on the outside as well as the inside of the carton. We will not accept any item back without this number. Proof of purchase must accompany the merchandise.

Please feel free to write or call us if you have any questions about the machine or the manual.

Thank you again for your business and continued support. We hope to serve you again soon.

To take advantage of this warranty, you must register it at <https://www.grizzly.com/forms/warranty>, or you can scan the QR code below to be automatically directed to our warranty registration page. Enter all applicable information for the product.



grizzly.com[®]

TOOL WEBSITE

Buy Direct and Save with Grizzly[®] – Trusted, Proven and a Great Value!
~Since 1983~

*Visit Our Website Today For
Current Specials!*

**ORDER
24 HOURS A DAY!
1-800-523-4777**

