

READ THIS FIRST



Model G0573

IMPORTANT UPDATE

For Machines Mfg. Since October, 2013
and Owner's Manual Printed August, 2007

For questions or help with this product contact Tech Support at (570) 546-9663 or techsupport@grizzly.com

The following changes were made since the owner's manual was printed:

- Casters are no longer installed when shipped.

Aside from this information, all other content in the owner's manual applies and **MUST** be read and understood for your own safety. **IMPORTANT: Keep this update with the owner's manual for future reference.**

For questions or help, contact our Tech Support at (570) 546-9663 or techsupport@grizzly.com.

Caster Hardware & Mounting

The casters and related mounting hardware are now shipped inside the machine.

Before operating machine, remove casters and secure to bottom of machine using the supplied fasteners, as shown.

31	P0573031	CASTER
32	P0573032	SKID CASTER
33	PW03M	FLAT WASHER 6MM
34	PB83M	HEX BOLT M6-1 X 16
39	PLW03M	LOCK WASHER 6MM

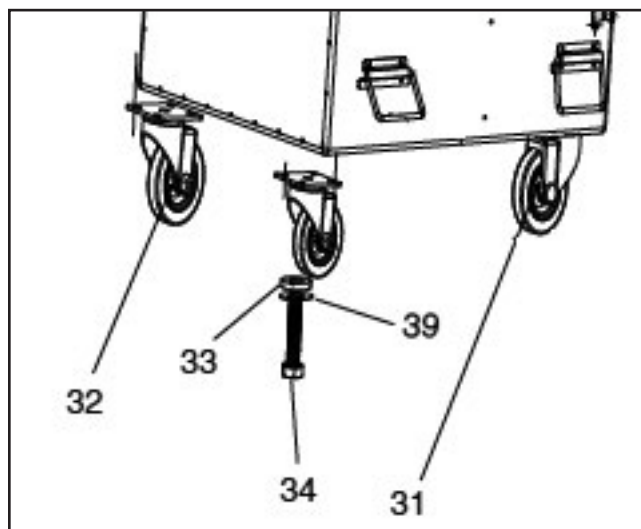

COPYRIGHT © OCTOBER, 2013 BY GRIZZLY INDUSTRIAL, INC. REVISED MARCH, 2014 (TR)

WARNING: NO PORTION OF THIS MANUAL MAY BE REPRODUCED IN ANY SHAPE OR FORM WITHOUT THE WRITTEN APPROVAL OF GRIZZLY INDUSTRIAL, INC.

#TR16068 PRINTED IN CHINA



**TWO SPEED
FLOOR AIR FILTER
MODEL G0573
INSTRUCTION MANUAL**



COPYRIGHT © DECEMBER, 2004 BY GRIZZLY INDUSTRIAL, INC. REVISED AUGUST, 2007 (BL)
**WARNING: NO PORTION OF THIS MANUAL MAY BE REPRODUCED IN ANY SHAPE
OR FORM WITHOUT THE WRITTEN APPROVAL OF GRIZZLY INDUSTRIAL, INC.**
#BL6811 PRINTED IN CHINA

WARNING

Some dust created by power sanding, sawing, grinding, drilling, and other construction activities contains chemicals known to the State of California to cause cancer, birth defects or other reproductive harm. Some examples of these chemicals are:

- Lead from lead-based paints.
- Crystalline silica from bricks, cement, and other masonry products.
- Arsenic and chromium from chemically treated lumber.

Your risk from these exposures varies, depending on how often you do this type of work. To reduce your exposure to these chemicals: work in a well ventilated area, and work with approved safety equipment, such as those dust masks that are specially designed to filter out microscopic particles.

Table of Contents

INTRODUCTION	2
Foreword	2
Contact Info.....	2
SECTION 1: SAFETY	3
Safety Instructions for Machinery.....	3
SECTION 2: CIRCUIT REQUIREMENTS	6
110V Operation	6
SECTION 3: SET UP	7
Set Up Safety	7
Items Needed For Set Up	7
Unpacking	7
SECTION 4: OPERATIONS	10
Operation Safety	10
Operations.....	10
Available Accessories	10
SECTION 5: MAINTENANCE	11
G0573 Wire Diagram	12
G0573 Parts Breakdown	13
WARRANTY AND RETURNS	16

INTRODUCTION

Foreword

We are proud to offer the Model G0573 Two Speed Floor Air Filter. This machine is part of a growing Grizzly family of fine woodworking machinery. When used according to the guidelines set forth in this manual, you can expect years of trouble-free, enjoyable operation and proof of Grizzly's commitment to customer satisfaction.

We are pleased to provide this manual with the Model G0573. It was written to guide you through assembly, review safety considerations, and cover general operating procedures.

The specifications, drawings, and photographs illustrated in this manual represent the Model G0573 as supplied when the manual was prepared. For your convenience, we always keep current Grizzly manuals available on our website at www.grizzly.com. Any updates to your machine will be reflected in these manuals as soon as they are complete.



Contact Info

If you have any comments regarding this manual, please write to us at the address below:

Grizzly Industrial, Inc.
c/o Technical Documentation
P.O. Box 2069
Bellingham, WA 98227-2069

We stand behind our machines. If you have any service questions or parts requests, please call or write us at the location listed below.

Grizzly Industrial, Inc.
1203 Lycoming Mall Circle
Muncy, PA 17756
Phone: (570) 546-9663
Fax: (800) 438-5901
E-Mail: techsupport@grizzly.com
Web Site: <http://www.grizzly.com>



Grizzly
Industrial, Inc.®

MACHINE DATA SHEET

Customer Service #: (570) 546-9663 • To Order Call: (800) 523-4777 • Fax #: (800) 438-5901

MODEL G0573 TWO SPEED FLOOR AIR FILTER

Motor1¼ HP, 2-Speed, 110 Volt, 1 PH
Amp Draw.....HI = 14 Amps, LO = 12 Amps
Dimensions..... 30 ½"L x 25 ¾" W x 29 ¾"H
Pre-Filter Dimensions..... 25"L x 25"H x 7/8"D
Primary Filter Dimensions 24"L x 24"H x 11¾"D
Weight165 lbs.
Airflow..... 1500 to 2000 CFM
Pre-Filter Filtration..... 3 Microns
Primary Filter Filtration .. .3 Microns (2000 CFM)

SECTION 1: SAFETY

WARNING

For Your Own Safety, Read Instruction Manual Before Operating this Machine

The purpose of safety symbols is to attract your attention to possible hazardous conditions. This manual uses a series of symbols and signal words which are intended to convey the level of importance of the safety messages. The progression of symbols is described below. Remember that safety messages by themselves do not eliminate danger and are not a substitute for proper accident prevention measures.

 **DANGER** Indicates an imminently hazardous situation which, if not avoided, **WILL** result in death or serious injury.

 **WARNING** Indicates a potentially hazardous situation which, if not avoided, **COULD** result in death or serious injury.

 **CAUTION** Indicates a potentially hazardous situation which, if not avoided, **MAY** result in minor or moderate injury. It may also be used to alert against unsafe practices.

NOTICE This symbol is used to alert the user to useful information about proper operation of the machine.

WARNING

Safety Instructions for Machinery

- 1. READ THROUGH THE ENTIRE MANUAL BEFORE STARTING MACHINERY.** Machinery presents serious injury hazards to untrained users.
- 2. ALWAYS USE ANSI APPROVED SAFETY GLASSES WHEN OPERATING MACHINERY.** Everyday eyeglasses only have impact resistant lenses, they are NOT safety glasses.
- 3. ALWAYS WEAR AN ANSI APPROVED RESPIRATOR WHEN OPERATING MACHINERY THAT PRODUCES DUST.** Wood dust is a carcinogen and can cause cancer and severe respiratory illnesses.
- 4. ALWAYS USE HEARING PROTECTION WHEN OPERATING MACHINERY.** Machinery noise can cause permanent hearing damage.
- 5. WEAR PROPER APPAREL. DO NOT** wear loose clothing, gloves, neckties, rings, or jewelry which may get caught in moving parts. Wear protective hair covering to contain long hair and wear non-slip footwear.
- 6. NEVER OPERATE MACHINERY WHEN TIRED, OR UNDER THE INFLUENCE OF DRUGS OR ALCOHOL.** Be mentally alert at all times when running machinery.

WARNING

Safety Instructions for Machinery

7. **ONLY ALLOW TRAINED AND PROPERLY SUPERVISED PERSONNEL TO OPERATE MACHINERY.** Make sure operation instructions are safe and clearly understood.
8. **KEEP CHILDREN AND VISITORS AWAY.** Keep all children and visitors a safe distance from the work area.
9. **MAKE WORKSHOP CHILD PROOF.** Use padlocks, master switches, and remove start switch keys.
10. **NEVER LEAVE WHEN MACHINE IS RUNNING.** Turn power *OFF* and allow all moving parts to come to a complete stop before leaving machine unattended.
11. **DO NOT USE IN DANGEROUS ENVIRONMENTS.** DO NOT use machinery in damp, wet locations, or where any flammable or noxious fumes may exist.
12. **KEEP WORK AREA CLEAN AND WELL LIT.** Clutter and dark shadows may cause accidents.
13. **USE A GROUNDED EXTENSION CORD RATED FOR MACHINE AMPERAGE.** Undersized cords overheat and lose power. Replace extension cords if they become damaged. DO NOT use extension cords for 220V machinery.
14. **ALWAYS DISCONNECT FROM POWER SOURCE BEFORE SERVICING MACHINERY.** Make sure switch is in OFF position before reconnecting.
15. **MAINTAIN MACHINERY WITH CARE.** Keep blades sharp and clean for best and safest performance. Follow instructions for lubricating and changing accessories.
16. **MAKE SURE GUARDS ARE IN PLACE AND WORK CORRECTLY BEFORE USING MACHINERY.**
17. **REMOVE ADJUSTING KEYS AND WRENCHES.** Make a habit of checking for keys and adjusting wrenches before turning machinery *ON*.
18. **CHECK FOR DAMAGED PARTS BEFORE USING MACHINERY.** Check for binding and alignment of parts, broken parts, part mounting, loose bolts, and any other conditions that may affect machine operation. Repair or replace damaged parts.
19. **USE RECOMMENDED ACCESSORIES.** Refer to the instruction manual for recommended accessories. The use of improper accessories may cause risk of injury.
20. **DO NOT FORCE MACHINERY.** Work at the speed for which the machine or accessory was designed.
21. **SECURE WORKPIECE.** Use clamps or a vise to hold the workpiece when practical. A secured workpiece protects your hands and frees both hands to operate the machine.
22. **DO NOT OVERREACH.** Keep proper footing and balance at all times.
23. **MANY MACHINES WILL EJECT WORKPIECE TOWARD OPERATOR.** Know and avoid conditions that cause the workpiece to "kickback."
24. **ALWAYS LOCK MOBILE BASES BEFORE OPERATING MACHINERY.**

WARNING

Additional Safety for Air Filters

- 1. FILTER USE.** This filter unit is only designed to remove very fine wood particles from the air. **DO NOT** use this machine to filter or collect liquids (especially flammables), metal shavings, lead paint, or asbestos. **DO NOT** use this machine to dissipate smoke, fumes, or when spraying paint.
- 2. FILTER REMOVAL.** Unplug machine before removing filter. Removing primary filter exposes the impeller, which may cause serious injury during contact if the machine is connected to the power source.
- 3. PROBLEMS WITH MOVING PARTS.** Problems concerned with moving parts or accessories must be investigated and corrected with the power disconnected and after the fan blade come to a complete stop.
- 4. EXPLOSION RISK.** Suspended dust particles in conjunction with an ignition source may cause an explosion. Do not operate this machine in areas where explosion risks would be high if dust were dispersed into the area. Areas of high risk include, but are not limited to, areas near pilot lights or open flames.
- 5. BURNING OR SMOKING MATERIAL.** Avoid collecting any material that is burning or smoking, including matches, cigarettes, and hot ashes.
- 6. MACHINE OPERATION.** Always operate the machine with the filter in place. When the primary filter is removed, the impeller is exposed to the unfiltered opening.
- 7. FILTER CLEANING AND REPLACEMENT.** Wear a respirator and safety glasses when changing or replacing filters. Empty dust into an approved container and dispose of properly.
- 8. OPERATING DIFFICULTIES.** If at any time you are experiencing difficulties performing the intended operation, stop using the machine! Then contact our service department or ask a qualified expert how the operation should be performed.
- 9. ALLERGIC REACTIONS.** Be aware that certain woods may cause an allergic reaction in people and animals, especially when exposed to fine dust. Make sure you know what type of wood dust you will be exposed to in case there is a possibility of an allergic reaction. Always wear an ANSI approved respirator!
- 10. LEAD-PAINT DUST OR ASBESTOS FIBERS.** This machine will not protect against lead-paint dust or asbestos fibers. These materials must be collected with special equipment due to high hazard to human health. **DO NOT** attempt to collect these materials with this machine.

WARNING

Like all machines there is danger associated with the Model G0573. Accidents are frequently caused by lack of familiarity or failure to pay attention. Use this machine with respect and caution to lessen the possibility of operator injury. If normal safety precautions are overlooked or ignored, serious personal injury may occur.

CAUTION

No list of safety guidelines can be complete. Every shop environment is different. Always consider safety first, as it applies to your individual working conditions. Use this and other machinery with caution and respect. Failure to do so could result in serious personal injury, damage to equipment, or poor work results.

SECTION 2: CIRCUIT REQUIREMENTS

110V Operation

! WARNING

Serious personal injury could occur if you connect the machine to the power source before you have completed the set up process. **DO NOT** connect the machine to the power source until instructed to do so.

Amperage Draw

The 1 $\frac{3}{4}$ HP motor on the Model G0573 will draw the following amps:

Motor Load 12-14 Amps

Circuit Breaker Requirements

Install your machine on a dedicated circuit to reduce the possibility of tripping the circuit breaker. If the circuit breaker frequently trips, have the circuit inspected by a qualified electrician. Never use a larger circuit breaker than stated below, or you will increase the risk of fire.

Circuit Breaker..... 15 Amp

Plug Type

The Model G0573 is supplied with an inverted-type 5-15 plug. You must insert an extension cord receptacle over the inverted plug and then insert the male part of the extension cord into a 5-15 wall receptacle.



! WARNING
Electrocution or fire could result if this machine is not grounded correctly or if your electrical configuration does not comply with local and state codes. Ensure compliance by checking with a qualified electrician!

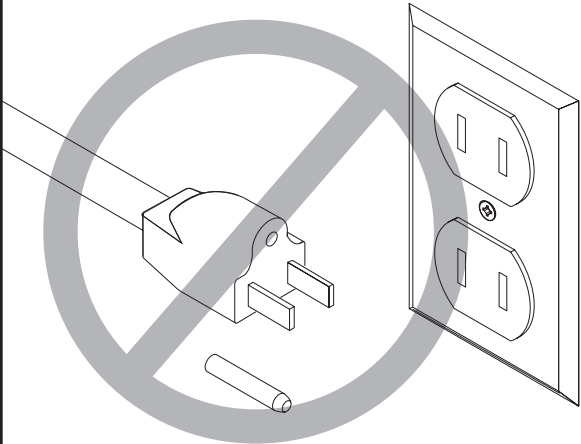

! CAUTION
This machine must have a ground prong in the plug to help ensure that it is grounded. **DO NOT** remove ground prong from plug to fit into a two-pronged outlet! If the plug will not fit the outlet, have the proper outlet installed by a qualified electrician.

Extension Cords

- Make sure the cord is rated Standard Service (grade S) or better.
- The extension cord must contain a ground wire and plug pin.
- Use at least a 16 gauge cord.
- DO NOT use a cord longer than 50 feet!.



SECTION 3: SET UP

Set Up Safety

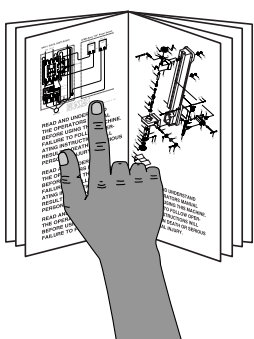

!WARNING
This machine presents serious injury hazards to untrained users. Read through this entire manual to become familiar with the controls and operations before starting the machine!



!WARNING
Wear safety glasses during the entire set up process!



!WARNING
The Model G0573 is a heavy machine (165 lbs. shipping weight). DO NOT over-exert yourself while unpacking or moving your machine—get assistance.



Items Needed For Set Up

The following items are needed to complete the set up process, but are not included with your machine:

DESCRIPTION	QTY
• 16 gauge extension cord (50 feet or less)	. 1
• 12" diameter ducting (optional) 1

Simply attach the female end of a 16 gauge extension cord onto the male 5-15 inverted plug on the air filter, then plug the extension cord into a grounded wall receptacle.

(Optional) To carry exhaust outside your shop, you can attach 12" diameter metal ducting to the exhaust vent.

Because of the high volume of air coming out of the Model G0573, you may want to attach a short length of ducting to control the direction of this airflow in your shop.



Unpacking

The Model G0573 was carefully packed when it left our warehouse. If you discover the machine is damaged after you have signed for delivery, *please immediately call Customer Service at (570) 546-9663 for advice.*

Save the containers and all packing materials for possible inspection by the carrier or its agent. *Otherwise, filing a freight claim can be difficult.*

When you are completely satisfied with the condition of your shipment, you should inventory the contents.



Shop Preparation

	<p>!WARNING DO NOT operate this air cleaner unit at a location where flammable fuels, solvents, or other volatile chemicals may exist. Since these products have a low flash point, the fan motor can ignite the fumes and cause an explosion and severe personal injury!</p>
---	--

	<p>!CAUTION Unsupervised children and visitors inside your shop could cause serious personal injury to themselves. Lock all entrances to the shop when you are away and DO NOT allow unsupervised children or visitors in your shop at any time!</p>
--	---

Operating Location

Operating this air cleaner unit in the incorrect environment can cause an explosion or respiratory damage to you and others. **This air cleaner unit is only designed to help remove very fine wood particles from the air. It is not a dust collector, so take all necessary safety precautions.** The operating location must be free of volatile fumes from fuels, paints, pesticides, chemicals, smoke, and other gasses; including an environment free of silica, metal, asbestos, hazardous bacterium, and other particles.

Working Clearances

Make sure there is 5-10' of clearance between the inlet and the outlet and any obstructions, as not to restrict the air flow. You may have to create or modify other shop ducting to achieve the correct working clearances and airflow.

Outlets

Make sure the electrical circuits have the capacity to handle the amperage requirements of the new air cleaner unit. Refer to **Page 6** for more information. Electrical outlets should be located near the unit so power or extension cords are clear of high-traffic areas.



Site Planning

Site planning is an important step to maximize the effectiveness of the air filter. Air circulation must be thought out and all obstructions to the air path considered.

Think of air circulation in terms of the circular motion of the air before and after the air filter. The air exiting the filter is exhausted at a higher velocity than that entering it. Consequently, exhaust being vented inside a building can have an effect on the pattern of air circulation.

The user may choose to vent exhaust horizontally from the 12" vent, install a short section of metal ducting onto the vent to deflect exhaust upward. Air circulation patterns will vary depending upon which method is used, and according to your specific shop setup.

Figure 1 shows an example of good air circulation where the user vents exhaust horizontally from the 12" exterior vent.

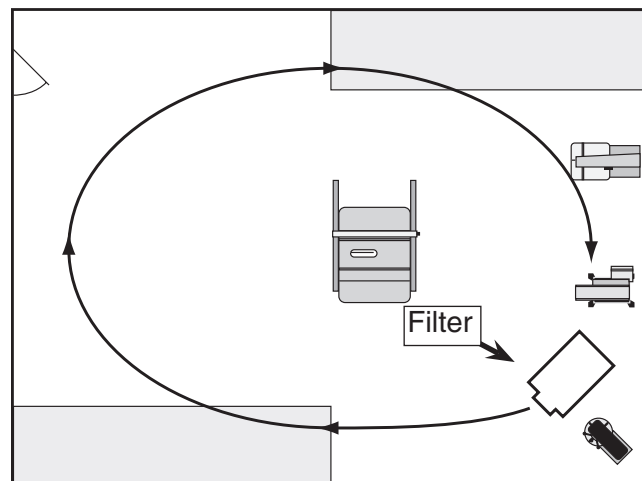

Figure 1. Good air circulation. The air filter placement promotes circular air motion.

Figure 2 shows an example of poor air circulation, where the air filter is placed too close to obstructions and the velocity of the air is lost and circulation is diminished.

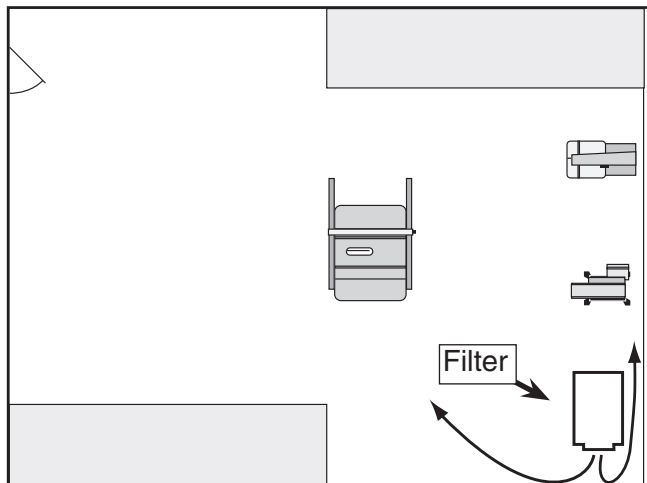

Figure 2. Poor air circulation, filter is placed too close to the wall.

Below is a list of things to keep in mind when selecting a spot for the air filter:

- Study your shop layout and try to determine the best location. Obstructed air flow will cause a short cycle effect, producing unsatisfactory results. There must be a clearance of at least 5-10' between the front and back of the unit and any obstructions.
- Try to place the air filter near areas where sanding will take place.
- Try to place the unit where it is easy to access for turning on, cleaning, and maintaining.



Filter Capacity

The G0573 Two Speed Floor Air Filter is designed to recirculate the entire volume of air in a 30' x 40' x 8' room approximately 12 times in one hour. For the best filtering effect, the volume in a room should be recirculated at least 6-8 times every hour.

To calculate the recirculating rate for a given volume:

Step 1. Calculate how long it takes to circulate all the volume of air in a room with the air filter; where W = Width, L = Length and H = Height of your room, in feet. The highest rate of air movement for the air filter is 2000 cubic feet per minute.

$$\frac{W' \times L' \times H'}{2000} = \text{Minutes for one recirculation change}$$

Step 1: $\frac{30' \times 40' \times 8'}{2000} = \frac{9600}{2000} = 4.8 \text{ Minutes}$

Step 2. Calculate how many times per hour the volume is recirculated through the air filter by dividing 60 minutes by the amount of time it takes to circulate the volume once. The result is listed as times per hour.

Step 2: $\frac{60}{4.8} = 12.5 \text{ Times per Hour}$



SECTION 4: OPERATIONS

Operation Safety

WARNING

Operating this equipment creates the potential for flying debris to cause eye injury. Always wear safety glasses when operating equipment. Everyday glasses or reading glasses only have impact resistant lenses, they are not safety glasses. Be certain the safety glasses you wear meet the appropriate standards of the American National Standards Institute (ANSI).



CAUTION

Operations that generate large amounts of any kind of dust may warrant the use of a respirator even though the dust filter is running. The dust filter is not a substitute for a respirator!



WARNING

THIS DUST FILTER IS TO BE USED FOR WOOD DUST ONLY. DO NOT use this machine to filter toxic fumes or paint spray. DO NOT use this machine to dissipate smoke or fumes.



Operations

To operate the unit:

1. Connect the unit to power and push the HI or LOW start switch. The fan should start up and begin filtering air in the room.
2. If it does not start, turn the switch *OFF* and disconnect the power.
 - Check the breaker/reset switch located next to the start switch and reset if needed.
 - Check to make sure the outlet connected to the filter is in working condition. Reset the breaker or replace the fuse if needed.

If the air filter continues to have problems, please call our customer support lines at (570) 546-9663 for troubleshooting information.



Available Accessories

Grizzly carries a complete selection of fine accessories for all of its equipment. Below is a list of accessories we are sure you will find useful.

- Dust Collection Basics, Model G2525
- Remote Dust Collector Switch, Model H2797 or H5397
- Primary Filter, P0573007
- Pre-Filter, P0573008

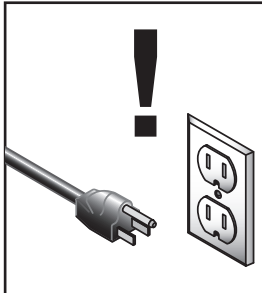

SECTION 5: MAINTENANCE

	<p>! WARNING</p> <p>To avoid personal injury, disconnect power to air filter when performing any adjustments, cleaning or maintenance.</p>
---	---

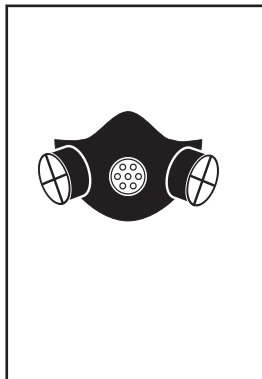
	<p>! CAUTION</p> <p>Use a respirator when cleaning or changing filters. Dust will become airborne creating a respiratory hazard. For safety, run the air filter for at least 6 minutes while wearing the respirator after cleaning.</p>
---	--

Cleaning the Filters

To maintain optimal operation, the filters in the Two Speed Floor Air Filter should be checked and cleaned or replaced regularly depending on usage. We recommend checking the primary filter and pre-filter once a month or more often if usage is high. Always wear a respirator when checking the filters.

To check, clean or replace the filters:

1. Disconnect power to the air filter.
2. Disengage the latches and swing open the front door.
3. Remove the pre-filter, place it inside a trash bag, and gently shake the dust from the filter.

Note—The pre-filter can be washed with water to remove the last of the dust and help maximize its filtering effect. DO NOT use compressed air to clean the pre-filter, as it may get damaged and lose its filtering capabilities.

4. Be sure the pre-filter is completely dry before re-installing it into the air filter.

<p>! CAUTION</p> <p>The primary air filter is heavy and could cause injuries if it drops on your feet. Use care when sliding it out of the air filter cabinet.</p>

5. Slide the primary air filter out of the air filter cabinet.
6. Slide a new primary air filter into the air filter cabinet, shut the door and engage the latches.

During regular use, the pre-filter can be cleaned several times before it needs to be replaced. It is important to look for holes in the pre-filter that would reduce the filtering effect. Please see the current Grizzly catalog for replacement information.



G0573 Wiring Diagram

⚠ DANGER

Disconnect power from machine before performing any electrical service. Failure to do this will result in a shock hazard leading to injury or death.

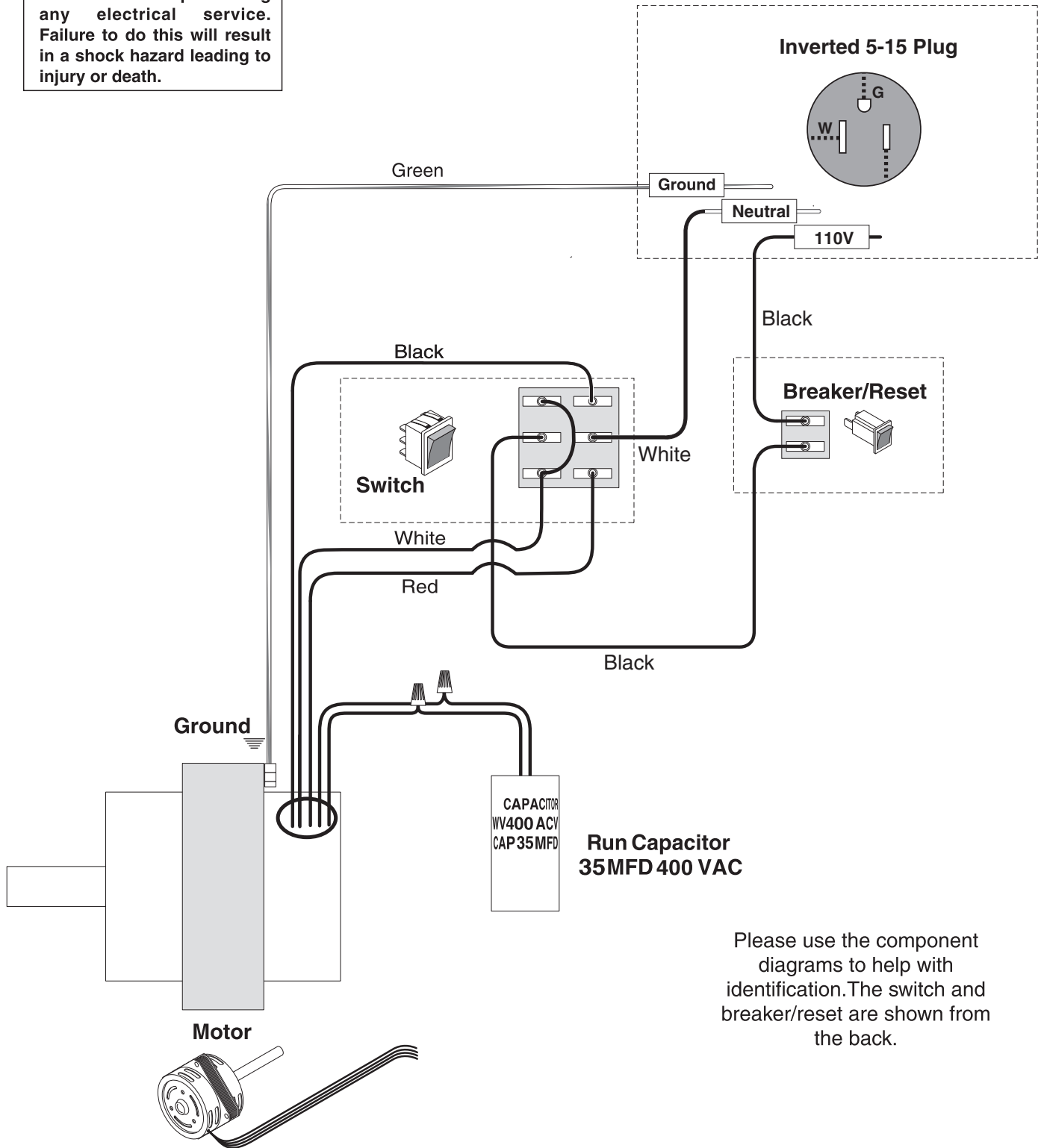

Please use the component diagrams to help with identification. The switch and breaker/reset are shown from the back.

G0573 Parts Breakdown

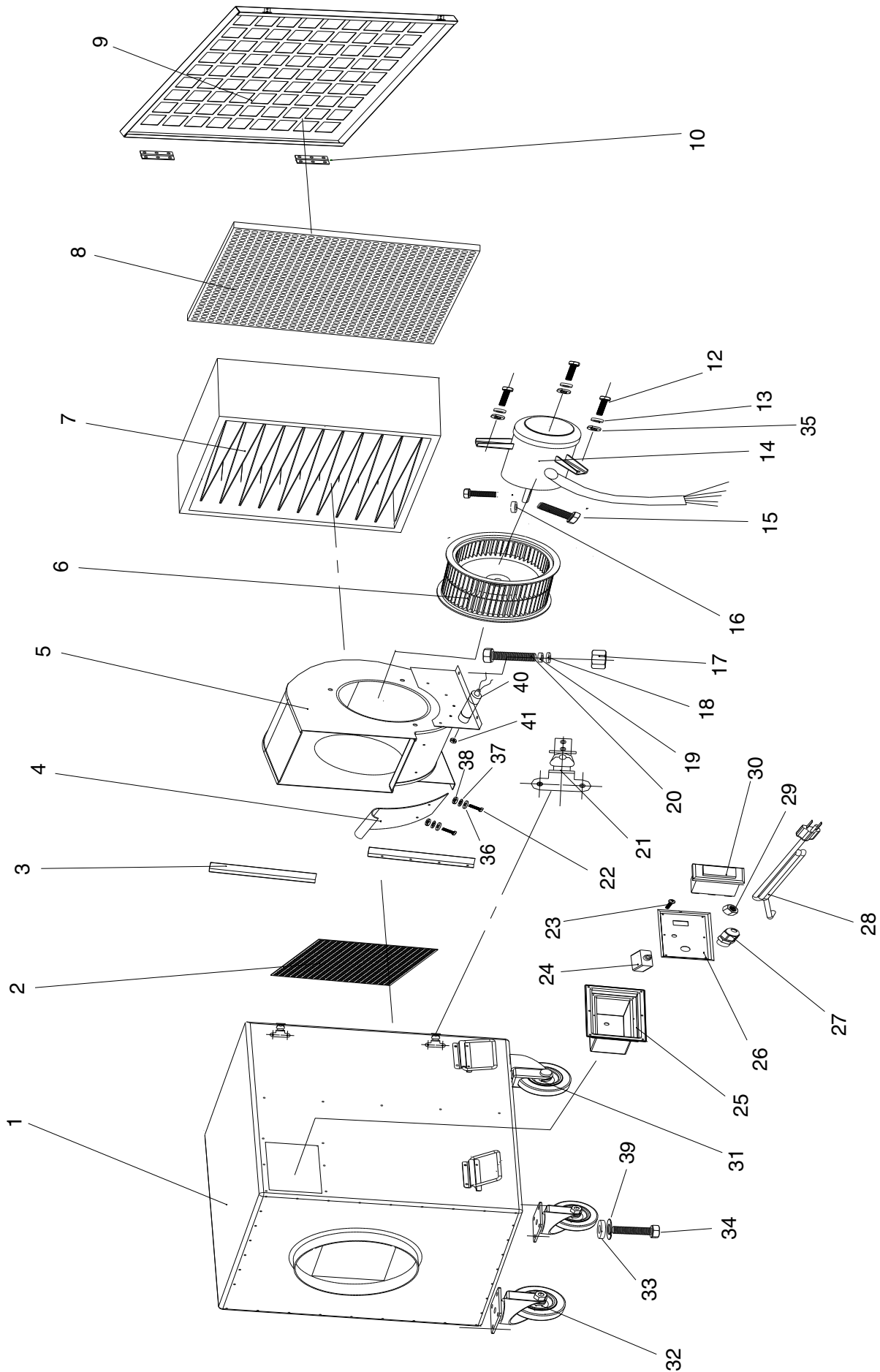

G0573 Parts List

REF	PART #	DESCRIPTION
1	P0573001	BODY
2	P0573002	STEELY GRATE
3	P0573003	ANGLE IRON
4	P0573004	FAN PLATE
5	P0573005	FAN HOUSING
6	P0573006	FAN BLADE
7	P0573007	PRIMARY FILTER
8	P0573008	PRE-FILTER
9	P0573009	INLET AIR DOOR
10	P0573010	CONNECTOR HINGE
12	PB09M	HEX BOLT M8-1.25 X 20
13	PW01M	FLAT WASHER 8MM
14	P0573014	MOTOR
15	PB09M	HEX BOLT M8-1.25 X 20
16	PN03M	HEX NUT M8-1.25
17	PN03M	HEX NUT M8-1.25
18	PW01M	FLAT WASHER 8MM
19	PLW04M	LOCK WASHER 8MM
20	PB07M	HEX BOLT M8-1.25 X 25
21	P0573021	DOOR LATCH

REF	PART #	DESCRIPTION
22	PS21M	PHLP HD SCR M4-.7 X 15
23	PHTEK5M	TAP SCREW M4.2 X 12
24	P0573024	FUSE
25	P0573025	SWITCH BOX
26	P0573026	SWITCH PLATE
27	P0573027	STRAIN RELIEF M20 X 1.5
28	P0573028	POWER CORD W/ PLUG
29	PN02M	HEX NUT M10-1.5
30	P0573030	SWITCH
31	P0573031	CASTER
32	P0573032	SKID CASTER
33	PW03M	FLAT WASHER 6MM
34	PB83M	HEX BOLT M6-1 X 16
35	PLW04M	LOCK WASHER 8MM
36	PW03	FLAT WASHER #10
37	PLW03	LOCK WASHER #10
38	PN04M	HEX NUT M4-.7
39	PLW03M	LOCK WASHER 6MM
40	P0573040	CAPACITOR 35 MFD 400 VAC
41	PN03M	HEX NUT M8-1.25

Troubleshooting

Symptom	Possible Cause	Possible Solution
The air cleaner does not operate at all.	<ol style="list-style-type: none"> 1. The power supply circuit breaker is tripped. 2. No power to the control panel 3. Wiring is at fault 4. The control panel circuit board is at fault. 5. The motor is at fault. 	<ol style="list-style-type: none"> 1. Correct the cause for high current draw and close the circuit breaker. 2. Replace the blown fuse in the control panel. 3. Repair, replace wires, plugs and cables as applicable; and make sure all electrical plugs and connections are secure. 4. Replace the circuit board. 5. Replace the motor.
The air cleaner CFM output is reduced.	<ol style="list-style-type: none"> 1. The filters are wet or clogged. 2. The airflow path is obstructed. 3. The control panel circuit board is at fault. 4. The motor is at fault. 	<ol style="list-style-type: none"> 1. Replace the primary filter and clean the pre-filter. 2. Remove obstructions or add ducting. 3. Replace the control panel circuit board. 4. Replace the motor.
The air filter unit is noisy or vibrates.	<ol style="list-style-type: none"> 1. The mounting is loose. 2. The unit is not level. 3. The fan or motor is loose. 	<ol style="list-style-type: none"> 1 Level the air cleaner unit. 2. Unplug the unit, remove the filters, and tighten all loose fasteners.



	<p>⚠ WARNING Disconnect power to the machine when performing any troubleshooting. Failure to do this may result in serious personal injury.</p>
--	---

WARRANTY AND RETURNS

Grizzly Industrial, Inc. warrants every product it sells for a period of **1 year** to the original purchaser from the date of purchase. This warranty does not apply to defects due directly or indirectly to misuse, abuse, negligence, accidents, repairs or alterations or lack of maintenance. This is Grizzly's sole written warranty and any and all warranties that may be implied by law, including any merchantability or fitness, for any particular purpose, are hereby limited to the duration of this written warranty. We do not warrant or represent that the merchandise complies with the provisions of any law or acts unless the manufacturer so warrants. In no event shall Grizzly's liability under this warranty exceed the purchase price paid for the product and any legal actions brought against Grizzly shall be tried in the State of Washington, County of Whatcom.

We shall in no event be liable for death, injuries to persons or property or for incidental, contingent, special, or consequential damages arising from the use of our products.

To take advantage of this warranty, contact us by mail or phone and give us all the details. We will then issue you a "Return Number," which must be clearly posted on the outside as well as the inside of the carton. We will not accept any item back without this number. Proof of purchase must accompany the merchandise.

The manufacturers reserve the right to change specifications at any time because they constantly strive to achieve better quality equipment. We make every effort to ensure that our products meet high quality and durability standards and we hope you never need to use this warranty.

Please feel free to write or call us if you have any questions about the machine or the manual.

Thank you again for your business and continued support. We hope to serve you again soon.



WARRANTY CARD

Name _____
 Street _____
 City _____ State _____ Zip _____
 Phone # _____ Email _____ Invoice # _____
 Model # _____ Order # _____ Serial # _____

The following information is given on a voluntary basis. It will be used for marketing purposes to help us develop better products and services. **Of course, all information is strictly confidential.**

1. How did you learn about us?

Advertisement Friend Catalog
 Card Deck Website Other:

2. Which of the following magazines do you subscribe to?

<input type="checkbox"/> Cabinet Maker	<input type="checkbox"/> Popular Mechanics	<input type="checkbox"/> Today's Homeowner
<input type="checkbox"/> Family Handyman	<input type="checkbox"/> Popular Science	<input type="checkbox"/> Wood
<input type="checkbox"/> Hand Loader	<input type="checkbox"/> Popular Woodworking	<input type="checkbox"/> Wooden Boat
<input type="checkbox"/> Handy	<input type="checkbox"/> Practical Homeowner	<input type="checkbox"/> Woodshop News
<input type="checkbox"/> Home Shop Machinist	<input type="checkbox"/> Precision Shooter	<input type="checkbox"/> Woodsmith
<input type="checkbox"/> Journal of Light Cont.	<input type="checkbox"/> Projects in Metal	<input type="checkbox"/> Woodwork
<input type="checkbox"/> Live Steam	<input type="checkbox"/> RC Modeler	<input type="checkbox"/> Woodworker West
<input type="checkbox"/> Model Airplane News	<input type="checkbox"/> Rifle	<input type="checkbox"/> Woodworker's Journal
<input type="checkbox"/> Modeltec	<input type="checkbox"/> Shop Notes	<input type="checkbox"/> Other:
<input type="checkbox"/> Old House Journal	<input type="checkbox"/> Shotgun News	

3. What is your annual household income?

\$20,000-\$29,000 \$30,000-\$39,000 \$40,000-\$49,000
 \$50,000-\$59,000 \$60,000-\$69,000 \$70,000+

4. What is your age group?

20-29 30-39 40-49
 50-59 60-69 70+

5. How long have you been a woodworker/metalworker?

0-2 Years 2-8 Years 8-20 Years 20+ Years

6. How many of your machines or tools are Grizzly?

0-2 3-5 6-9 10+

7. Do you think your machine represents a good value?

Yes No

8. Would you recommend Grizzly Industrial to a friend?

Yes No

9. Would you allow us to use your name as a reference for Grizzly customers in your area?

Note: *We never use names more than 3 times.* Yes No

10. Comments: _____

CUT ALONG DOTTED LINE

FOLD ALONG DOTTED LINE



Place
Stamp
Here



GRIZZLY INDUSTRIAL, INC.
P.O. BOX 2069
BELLINGHAM, WA 98227-2069



FOLD ALONG DOTTED LINE

Send a Grizzly Catalog to a friend:

Name _____
Street _____
City _____ State _____ Zip _____

TAPE ALONG EDGES--PLEASE DO NOT STAPLE

grizzly.com

TOOL WEBSITE

Buy Direct and Save with Grizzly® – Trusted, Proven and a Great Value!

*Visit Our Website Today And Discover Why
Grizzly® Is The Industry Leader!*

- SECURE ORDERING
- ORDERS SHIPPED WITHIN 24 HOURS
- E-MAIL RESPONSE WITHIN ONE HOUR

-OR-

Call Today For A **FREE**
Full Color Catalog

1-800-523-4777

