

Grizzly **Industrial, Inc.**®

MODEL G0555X

14" EXTREME SERIES BANDSAW

OWNER'S MANUAL

(For models manufactured since 9/17)



C US
252923

COPYRIGHT © OCTOBER, 2006 BY GRIZZLY INDUSTRIAL, INC., REVISED AUGUST, 2018 (MN)

**WARNING: NO PORTION OF THIS MANUAL MAY BE REPRODUCED IN ANY SHAPE
OR FORM WITHOUT THE WRITTEN APPROVAL OF GRIZZLY INDUSTRIAL, INC.**

#TR8670 PRINTED IN TAIWAN

V4.08.18



WARNING!

This manual provides critical safety instructions on the proper setup, operation, maintenance, and service of this machine/tool. Save this document, refer to it often, and use it to instruct other operators.

Failure to read, understand and follow the instructions in this manual may result in fire or serious personal injury—including amputation, electrocution, or death.

The owner of this machine/tool is solely responsible for its safe use. This responsibility includes but is not limited to proper installation in a safe environment, personnel training and usage authorization, proper inspection and maintenance, manual availability and comprehension, application of safety devices, cutting/sanding/grinding tool integrity, and the usage of personal protective equipment.

The manufacturer will not be held liable for injury or property damage from negligence, improper training, machine modifications or misuse.



WARNING!

Some dust created by power sanding, sawing, grinding, drilling, and other construction activities contains chemicals known to the State of California to cause cancer, birth defects or other reproductive harm. Some examples of these chemicals are:

- **Lead from lead-based paints.**
- **Crystalline silica from bricks, cement and other masonry products.**
- **Arsenic and chromium from chemically-treated lumber.**

Your risk from these exposures varies, depending on how often you do this type of work. To reduce your exposure to these chemicals: Work in a well ventilated area, and work with approved safety equipment, such as those dust masks that are specially designed to filter out microscopic particles.

Table of Contents

INTRODUCTION	2	SECTION 5: ACCESSORIES	40
Contact Info.....	2	SECTION 6: MAINTENANCE	42
Manual Accuracy	2	Schedule.....	42
Machine Data Sheet	3	Cleaning.....	42
Identification.....	5	Lubricating	42
SECTION 1: SAFETY	6	Redressing Rubber Tires.....	42
Safety Instructions for Machinery	6	SECTION 7: SERVICE	43
Additional Safety for Bandsaws.....	8	Troubleshooting	43
SECTION 2: POWER SUPPLY	9	Tensioning V-Belt.....	46
SECTION 3: SETUP	12	Replacing V-Belt.....	47
Needed for Setup.....	12	Shimming Table.....	48
Unpacking.....	12	Correcting Blade Lead.....	48
Inventory	13	Calibrating Fence Scale.....	49
Hardware Recognition Chart	14	Wheel Alignment.....	50
Cleanup.....	15	Blade Tensioner.....	52
Site Considerations.....	16	SECTION 8: WIRING	53
Assembly	17	Wiring Safety Instructions	53
Dust Collection.....	20	110V Wiring Diagram.....	54
Adjustment Overview	20	220V Wiring Diagram.....	55
Initial Blade Tracking	20	SECTION 9: PARTS	56
Test Run	22	Main	56
Tensioning Blade	23	Table, Fence & Guides.....	59
Adjusting Blade Support Bearings.....	24	Stand.....	61
Adjusting Blade Guide Bearings.....	25	Labels & Cosmetics.....	62
Adjusting Positive Stop	26	WARRANTY AND RETURNS	65
Setting Table Tilt Scale to 0°	27		
Leveling Extension Table.....	27		
Aligning Table	28		
Aligning Fence.....	28		
SECTION 4: OPERATIONS	29		
Operation Overview	29		
General Overview	30		
Disabling & Locking Switch.....	30		
Workpiece Inspection.....	31		
Setting Upper Blade Guide Height	31		
Adjusting Table Tilt	32		
Blade Selection.....	32		
Blade Care & Break-In.....	35		
Blade Breakage	35		
Changing Blade	36		
Scale Calibration.....	37		
Ripping.....	37		
Crosscutting	38		
Resawing	38		
Cutting Curves.....	39		
Stacked Cuts.....	39		

INTRODUCTION

Contact Info

We stand behind our machines! If you have questions or need help, contact us with the information below. Before contacting, make sure you get the **serial number** and **manufacture date** from the machine ID label. This will help us help you faster.

Grizzly Technical Support
1815 W. Battlefield
Springfield, MO 65807
Phone: (570) 546-9663
Email: techsupport@grizzly.com

We want your feedback on this manual. What did you like about it? Where could it be improved? Please take a few minutes to give us feedback.

Grizzly Documentation Manager
P.O. Box 2069
Bellingham, WA 98227-2069
Email: manuals@grizzly.com

Manual Accuracy

We are proud to provide a high-quality owner's manual with your new machine!

We made every effort to be exact with the instructions, specifications, drawings, and photographs in this manual. Sometimes we make mistakes, but our policy of continuous improvement also means that **sometimes the machine you receive is slightly different than shown in the manual.**

If you find this to be the case, and the difference between the manual and machine leaves you confused or unsure about something, check our website for an updated version. We post current manuals and manual updates for free on our website at www.grizzly.com.

Alternatively, you can call our Technical Support for help. Before calling, make sure you write down the **Manufacture Date** and **Serial Number** from the machine ID label (see below). This information is required for us to provide proper tech support, and it helps us determine if updated documentation is available for your machine.

Grizzly Industrial		MODEL GXXXX MACHINE NAME
SPECIFICATIONS		▲ WARNING!
Motor:		To reduce risk of serious injury when using this machine:
Specification:	Manufacture Date	1. Read manual before operation.
Specification:		2. Wear safety glasses and respirator.
Specification:		3. Make sure safety is correctly adjusted/setup and
Weight:		4. power is connected to grounded circuit before starting.
		4. Make sure the motor has stopped and disconnect
		power before adjustments, maintenance, or service.
		5. DO NOT expose to rain or dampness.
		6. DO NOT modify this machine in any way.
		7.
		8.
		9. Serial Number
		10. Maintain machine carefully to prevent accidents.
Manufactured for Grizzly in Taiwan		





MACHINE DATA SHEET

Customer Service #: (570) 546-9663 · To Order Call: (800) 523-4777 · Fax #: (800) 438-5901

MODEL G0555X 14" EXTREME SERIES BANDSAW

Product Dimensions:

Weight..... 236 lbs.
Width (side-to-side) x Depth (front-to-back) x Height..... 30 x 26 x 67-1/4 in.
Footprint (Length x Width)..... 17-1/4 x 16 in.

Shipping Dimensions:

Carton #1

Type..... Cardboard Box
Content..... Machine
Weight..... 199 Lbs.
Length x Width x Height..... 21 x 41 x 20 in.
Must Ship Upright..... No

Carton #2

Type..... Cardboard Box
Content..... Stand
Weight..... 60 Lbs.
Length x Width x Height..... 17 x 18 x 26 in.
Must Ship Upright..... No

Electrical:

Power Requirement..... 110V or 220V, Single-Phase, 60 Hz
Prewired Voltage..... 110V
Full-Load Current Rating..... 15A at 110V, 7.5A at 220V
Minimum Circuit Size..... 20A at 110V, 15A at 220V
Connection Type..... Cord & Plug
Power Cord Included..... Yes
Power Cord Length..... 6 ft.
Power Cord Gauge..... 14 AWG
Plug Included..... Yes
Included Plug Type..... 5-15 for 110V
Recommended Plug Type..... 6-15 for 220V
Switch Type..... ON/OFF Push Button Switch

Motors:

Main

Horsepower..... 1.5 HP
Phase..... Single-Phase
Amps..... 15A/7.5A
Speed..... 1725 RPM
Type..... TEFC Capacitor-Start Induction
Power Transfer..... Belt Drive
Bearings..... Shielded & Permanently Lubricated
Centrifugal Switch/Contacts Type..... External



Main Specifications:

Main Specifications

Bandsaw Size.....	14 in.
Max Cutting Width (Left of Blade).....	13-1/2 in.
Max Cutting Width (Left of Blade) w/Fence.....	12-1/4 in.
Max Cutting Height (Resaw Height).....	6 in.
Blade Speeds.....	3000 FPM

Blade Information

Standard Blade Length.....	93-1/2 in.
Blade Length Range.....	92-1/2 – 93-1/2 in.
Blade Width Range.....	1/8 – 3/4 in.
Type of Blade Guides.....	Ball Bearing
Guide Post Adjustment Type.....	Manual
Has Quick-Release.....	Yes

Table Information

Table Length.....	14 in.
Table Width.....	20-1/2 in.
Table Thickness.....	1-1/2 in.
Table Tilt.....	Left 15, Right 45 deg.
Table Tilt Adjustment Type.....	Manual
Floor-to-Table Height.....	44 in.
Fence Locking Position.....	Front
Fence is Adjustable for Blade Lead.....	Yes
Resaw Fence Attachment Included.....	Yes
Miter Gauge Included.....	Yes

Construction Materials

Table.....	Precision Ground Cast Iron
Trunnion.....	Aluminum
Fence.....	Extruded Aluminum and Cast Iron
Base/Stand.....	Pre-Formed Steel
Frame/Body.....	Cast Iron
Wheels.....	Computer-Balanced Cast Iron
Tire.....	Rubber
Wheel Cover.....	Pre-Formed Steel
Paint Type/Finish.....	Powder Coating

Other Related Information

Wheel Diameter.....	13-3/4 in.
Wheel Width.....	1-3/16 in.
Number of Dust Ports.....	1
Dust Port Size.....	4 in.
Compatible Mobile Base.....	D2260A

Other Specifications:

Country of Origin.....	Taiwan
Warranty.....	1 Year
Approximate Assembly & Setup Time.....	1-1/2 Hours
Serial Number Location.....	ID Label on Top Cover
ISO 9001 Factory.....	Yes
Certified by a Nationally Recognized Testing Laboratory (NRTL).....	Yes
Awards.....	Popular Woodworking Best New Tool 2003



Identification

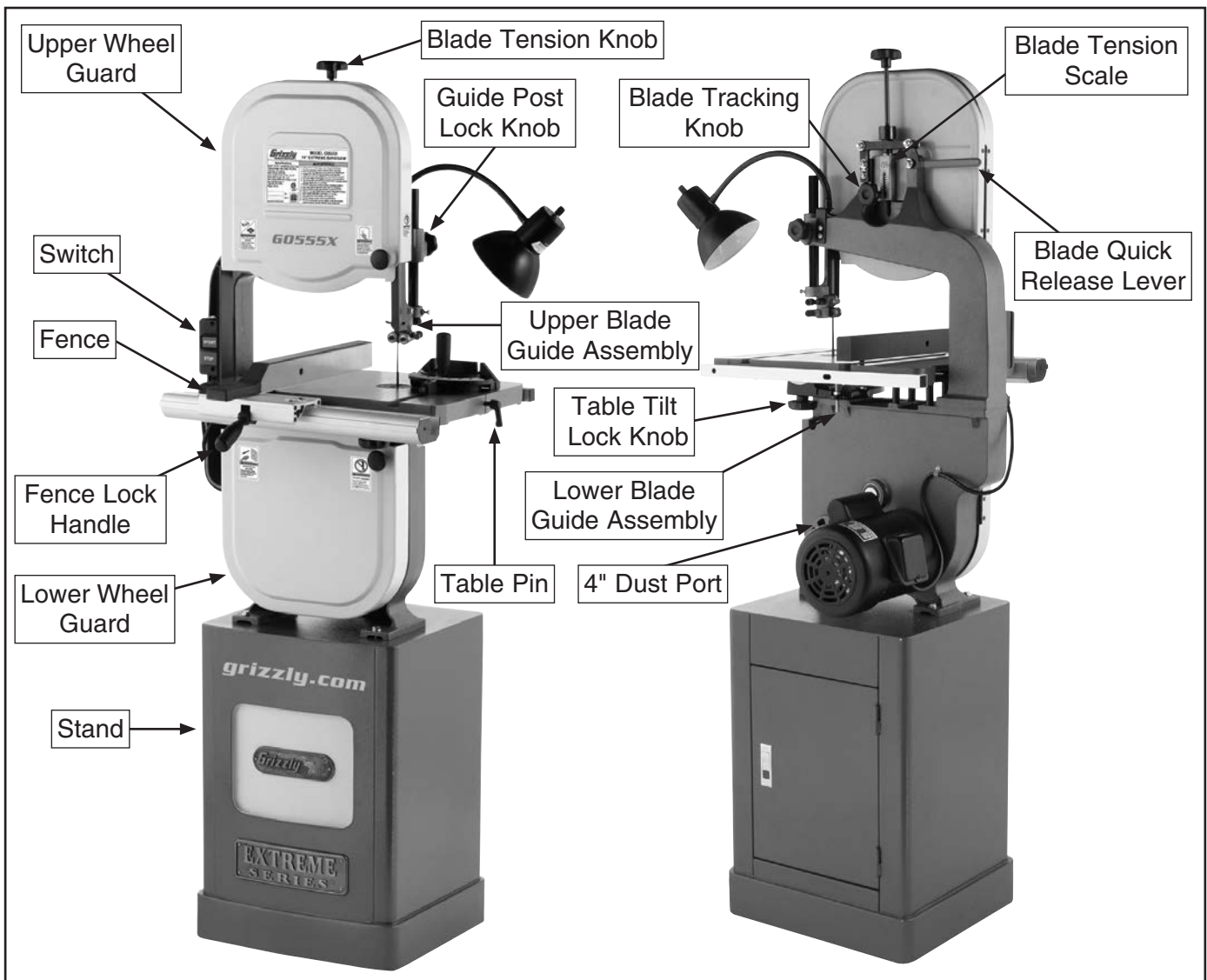

⚠️ WARNING

For Your Own Safety, Read Instruction Manual Before Operating Bandsaw

- a) Wear eye protection.
- b) Do not remove jammed cutoff pieces until blade has stopped.
- c) Maintain proper adjustment of blade tension, blade guides, and thrust bearings.
- d) Adjust upper guide to just clear workpiece.
- e) Hold workpiece firmly against table.



SECTION 1: SAFETY

For Your Own Safety, Read Instruction Manual Before Operating This Machine

The purpose of safety symbols is to attract your attention to possible hazardous conditions. This manual uses a series of symbols and signal words intended to convey the level of importance of the safety messages. The progression of symbols is described below. Remember that safety messages by themselves do not eliminate danger and are not a substitute for proper accident prevention measures. Always use common sense and good judgment.

 **DANGER** Indicates an imminently hazardous situation which, if not avoided, **WILL** result in death or serious injury.

 **WARNING** Indicates a potentially hazardous situation which, if not avoided, **COULD** result in death or serious injury.

 **CAUTION** Indicates a potentially hazardous situation which, if not avoided, **MAY** result in minor or moderate injury. It may also be used to alert against unsafe practices.

NOTICE This symbol is used to alert the user to useful information about proper operation of the machine.

Safety Instructions for Machinery

WARNING

OWNER'S MANUAL. Read and understand this owner's manual **BEFORE** using machine.

TRAINED OPERATORS ONLY. Untrained operators have a higher risk of being hurt or killed. Only allow trained/supervised people to use this machine. When machine is not being used, disconnect power, remove switch keys, or lock-out machine to prevent unauthorized use—especially around children. Make your workshop kid proof!

DANGEROUS ENVIRONMENTS. Do not use machinery in areas that are wet, cluttered, or have poor lighting. Operating machinery in these areas greatly increases the risk of accidents and injury.

MENTAL ALERTNESS REQUIRED. Full mental alertness is required for safe operation of machinery. Never operate under the influence of drugs or alcohol, when tired, or when distracted.

ELECTRICAL EQUIPMENT INJURY RISKS. You can be shocked, burned, or killed by touching live electrical components or improperly grounded machinery. To reduce this risk, only allow qualified service personnel to do electrical installation or repair work, and always disconnect power before accessing or exposing electrical equipment.

DISCONNECT POWER FIRST. Always disconnect machine from power supply **BEFORE** making adjustments, changing tooling, or servicing machine. This prevents an injury risk from unintended startup or contact with live electrical components.

EYE PROTECTION. Always wear ANSI-approved safety glasses or a face shield when operating or observing machinery to reduce the risk of eye injury or blindness from flying particles. Everyday eyeglasses are **NOT** approved safety glasses.



WARNING

WEARING PROPER APPAREL. Do not wear clothing, apparel or jewelry that can become entangled in moving parts. Always tie back or cover long hair. Wear non-slip footwear to reduce risk of slipping and losing control or accidentally contacting cutting tool or moving parts.

HAZARDOUS DUST. Dust created by machinery operations may cause cancer, birth defects, or long-term respiratory damage. Be aware of dust hazards associated with each workpiece material. Always wear a NIOSH-approved respirator to reduce your risk.

HEARING PROTECTION. Always wear hearing protection when operating or observing loud machinery. Extended exposure to this noise without hearing protection can cause permanent hearing loss.

REMOVE ADJUSTING TOOLS. Tools left on machinery can become dangerous projectiles upon startup. Never leave chuck keys, wrenches, or any other tools on machine. Always verify removal before starting!

USE CORRECT TOOL FOR THE JOB. Only use this tool for its intended purpose—do not force it or an attachment to do a job for which it was not designed. Never make unapproved modifications—modifying tool or using it differently than intended may result in malfunction or mechanical failure that can lead to personal injury or death!

AWKWARD POSITIONS. Keep proper footing and balance at all times when operating machine. Do not overreach! Avoid awkward hand positions that make workpiece control difficult or increase the risk of accidental injury.

CHILDREN & BYSTANDERS. Keep children and bystanders at a safe distance from the work area. Stop using machine if they become a distraction.

GUARDS & COVERS. Guards and covers reduce accidental contact with moving parts or flying debris. Make sure they are properly installed, undamaged, and working correctly BEFORE operating machine.

FORCING MACHINERY. Do not force machine. It will do the job safer and better at the rate for which it was designed.

NEVER STAND ON MACHINE. Serious injury may occur if machine is tipped or if the cutting tool is unintentionally contacted.

STABLE MACHINE. Unexpected movement during operation greatly increases risk of injury or loss of control. Before starting, verify machine is stable and mobile base (if used) is locked.

USE RECOMMENDED ACCESSORIES. Consult this owner's manual or the manufacturer for recommended accessories. Using improper accessories will increase the risk of serious injury.

UNATTENDED OPERATION. To reduce the risk of accidental injury, turn machine **OFF** and ensure all moving parts completely stop before walking away. Never leave machine running while unattended.

MAINTAIN WITH CARE. Follow all maintenance instructions and lubrication schedules to keep machine in good working condition. A machine that is improperly maintained could malfunction, leading to serious personal injury or death.

DAMAGED PARTS. Regularly inspect machine for damaged, loose, or mis-adjusted parts—or any condition that could affect safe operation. Immediately repair/replace BEFORE operating machine. For your own safety, DO NOT operate machine with damaged parts!

MAINTAIN POWER CORDS. When disconnecting cord-connected machines from power, grab and pull the plug—NOT the cord. Pulling the cord may damage the wires inside. Do not handle cord/plug with wet hands. Avoid cord damage by keeping it away from heated surfaces, high traffic areas, harsh chemicals, and wet/damp locations.

EXPERIENCING DIFFICULTIES. If at any time you experience difficulties performing the intended operation, stop using the machine! Contact our Technical Support at (570) 546-9663.



Additional Safety for Bandsaws

WARNING

Serious cuts, amputation, or death can occur from contact with the moving saw blade during operation or if blade breakage occurs. To reduce this risk, anyone operating this machine MUST completely heed the hazards and warnings below.

HAND PLACEMENT. Placing hands or fingers in line with blade during operation may result in serious injury if hands slip or workpiece moves unexpectedly. Do not position fingers or hands in line with blade, and never reach under table while blade is moving.

SMALL/NARROW WORKPIECES. If hands slip during a cut while holding small workpieces with fingers, serious personal injury could occur. Always support/feed small or narrow workpieces with push sticks, push blocks, jig, vise, or some type of clamping fixture.

BLADE SPEED. Cutting workpiece before blade is at full speed could cause blade to grab workpiece and pull hands into blade. Allow blade to reach full speed before starting cut. DO NOT start machine with workpiece contacting blade.

FEED RATE. To avoid risk of workpiece slipping and causing operator injury, always feed stock evenly and smoothly.

BLADE CONDITION. Dull blades require more effort to perform cut, increasing risk of accidents. Do not operate with dirty, dull, cracked or badly worn blades. Inspect blades for cracks and missing teeth before each use. Always maintain proper blade tension and tracking while operating.

CLEARING JAMS AND CUTOFFS. Always stop bandsaw and disconnect power before clearing scrap pieces that get stuck between blade and table insert. Use brush or push stick, not hands, to clean chips/cutoff scraps from table.

BLADE CONTROL. To avoid risk of injury due to blade contact, always allow blade to stop on its own. DO NOT try to stop or slow blade with your hand or the workpiece.

GUARDS/COVERS. Blade guards and covers protect operator from the moving bandsaw blade. The wheel covers protect operator from getting entangled with rotating wheels or other moving parts. ONLY operate this bandsaw with blade guard in proper position and wheel covers completely closed.

BLADE REPLACEMENT. To avoid mishaps that could result in operator injury, make sure blade teeth face down toward table and blade is properly tensioned and tracked before operating.

UPPER BLADE GUIDE SUPPORT. To reduce exposure of operator to blade and provide maximum blade support while cutting, keep upper blade guides adjusted to just clear workpiece.

CUTTING TECHNIQUES. To avoid blade getting pulled off wheels or accidentally breaking and striking operator, always turn bandsaw **OFF** and wait for blade to come to a complete stop before backing workpiece out of blade. DO NOT back workpiece away from blade while bandsaw is running. DO NOT force or twist blade while cutting, especially when sawing small curves. This could result in blade damage or breakage.

WORKPIECE SUPPORT. To maintain maximum control and reduce risk of blade contact/breakage, always ensure adequate support of long/large workpieces. Always keep workpiece flat and firm against table/fence when cutting to avoid loss of control. If necessary, use a jig or other workholding device.

WORKPIECE MATERIAL. This machine is intended for cutting natural and man-made wood products, and laminate covered wood products. This machine is NOT designed to cut metal, glass, stone, tile, etc.



SECTION 2: POWER SUPPLY

Availability

Before installing the machine, consider the availability and proximity of the required power supply circuit. If an existing circuit does not meet the requirements for this machine, a new circuit must be installed. To minimize the risk of electrocution, fire, or equipment damage, installation work and electrical wiring must be done by an electrician or qualified service personnel in accordance with all applicable codes and standards.

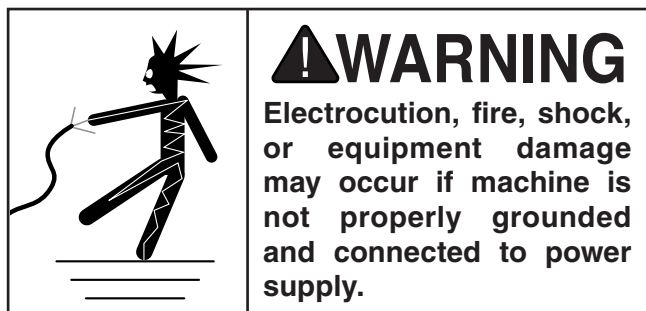

Full-Load Current Rating

The full-load current rating is the amperage a machine draws at 100% of the rated output power. On machines with multiple motors, this is the amperage drawn by the largest motor or sum of all motors and electrical devices that might operate at one time during normal operations.

Full-Load Current Rating at 110V..... 15 Amps

Full-Load Current Rating at 220V 7.5 Amps

The full-load current is not the maximum amount of amps that the machine will draw. If the machine is overloaded, it will draw additional amps beyond the full-load rating.

If the machine is overloaded for a sufficient length of time, damage, overheating, or fire may result—especially if connected to an undersized circuit. To reduce the risk of these hazards, avoid overloading the machine during operation and make sure it is connected to a power supply circuit that meets the specified circuit requirements.

Circuit Information

A power supply circuit includes all electrical equipment between the breaker box or fuse panel in the building and the machine. The power supply circuit used for this machine must be sized to safely handle the full-load current drawn from the machine for an extended period of time. (If this machine is connected to a circuit protected by fuses, use a time delay fuse marked D.)



Note: *Circuit requirements in this manual apply to a dedicated circuit—where only one machine will be running on the circuit at a time. If machine will be connected to a shared circuit where multiple machines may be running at the same time, consult an electrician or qualified service personnel to ensure circuit is properly sized for safe operation.*

Circuit Requirements for 110V

This machine is prewired to operate on a power supply circuit that has a verified ground and meets the following requirements:

Nominal Voltage 110V, 115V, 120V
Cycle.....60 Hz
Phase..... Single-Phase
Power Supply Circuit 20 Amps
Plug/Receptacle NEMA 5-15

Circuit Requirements for 220V

This machine can be converted to operate on a power supply circuit that has a verified ground and meets the requirements listed below. (Refer to **Voltage Conversion** instructions for details.)

Nominal Voltage 208V, 220V, 230V, 240V
Cycle.....60 Hz
Phase..... Single-Phase
Power Supply Circuit 15 Amps
Plug/Receptacle NEMA 6-15



Grounding Requirements

This machine **MUST** be grounded. In the event of certain malfunctions or breakdowns, grounding reduces the risk of electric shock by providing a path of least resistance for electric current.

For 110V operation: This machine is equipped with a power cord that has an equipment-grounding wire and a grounding plug (see following figure). The plug must only be inserted into a matching receptacle (outlet) that is properly installed and grounded in accordance with all local codes and ordinances.

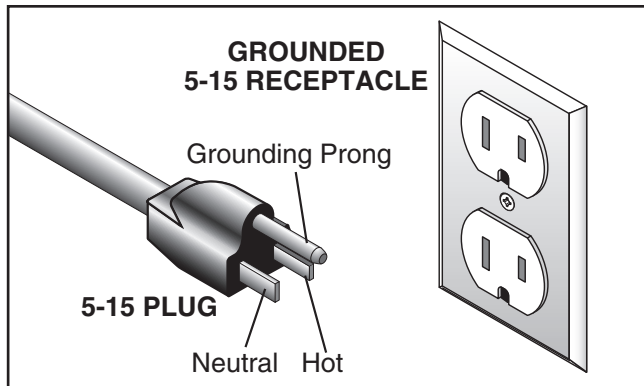

Figure 1. Typical 5-15 plug and receptacle.

For 220V operation: The plug specified under “Circuit Requirements for 220V” on the previous page has a grounding prong that must be attached to the equipment-grounding wire on the included power cord. The plug must only be inserted into a matching receptacle (see following figure) that is properly installed and grounded in accordance with all local codes and ordinances.

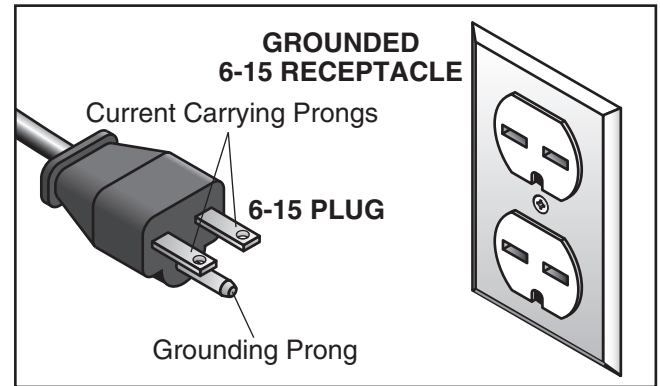

Figure 2. Typical 6-15 plug and receptacle.

Improper connection of the equipment-grounding wire can result in a risk of electric shock. The wire with green insulation (with or without yellow stripes) is the equipment-grounding wire. If repair or replacement of the power cord or plug is necessary, do not connect the equipment-grounding wire to a live (current carrying) terminal.

Check with a qualified electrician or service personnel if you do not understand these grounding requirements, or if you are in doubt about whether the tool is properly grounded. If you ever notice that a cord or plug is damaged or worn, disconnect it from power, and immediately replace it with a new one.

⚠ CAUTION

SHOCK HAZARD!

Two-prong outlets do not meet the grounding requirements for this machine. Do not modify or use an adapter on the plug provided—if it will not fit the outlet, have a qualified electrician install the proper outlet with a verified ground.



Extension Cords

We do not recommend using an extension cord with this machine. If you must use an extension cord, only use it if absolutely necessary and only on a temporary basis.

Extension cords cause voltage drop, which can damage electrical components and shorten motor life. Voltage drop increases as the extension cord size gets longer and the gauge size gets smaller (higher gauge numbers indicate smaller sizes).

Any extension cord used with this machine must be in good condition and contain a ground wire and matching plug/receptacle. Additionally, it must meet the following size requirements:

Minimum Gauge Size14 AWG
Maximum Length (Shorter is Better).....50 ft.

Work Lamp

The work lamp included with this machine is not part of the electrical wiring of the machine. The lamp must be connected to a separate grounded 120V circuit that accepts the included 5-15 plug.

Use only a replacement light bulb that is rated 40 watts or below. When changing the light bulb, always disconnect the lamp from power and wait for the bulb to cool.

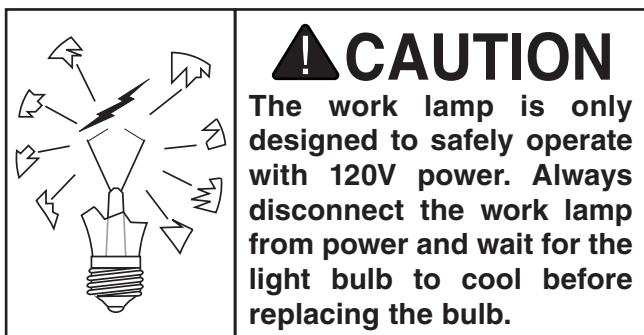

Voltage Conversion

The voltage conversion **MUST** be performed by an electrician or qualified service personnel.

To perform the voltage conversion, install the correct plug and rewire the motor to the new voltage, according to the provided wiring diagram on **Page 55**.

The START/STOP switch is a dual-voltage switch (110V/220V) and does not need to be re-wired or replaced.

Note: *If the diagram included on the motor conflicts with the one in this manual, the motor may have changed since the manual was printed. Use the diagram provided inside the motor wiring junction box.*

To convert machine to 220V:

1. DISCONNECT MACHINE FROM POWER!
2. Replace the 5-15 plug on the power cord with a 6-15 plug.
3. Re-wire the motor as illustrated in the wiring diagram on **Page 55**.

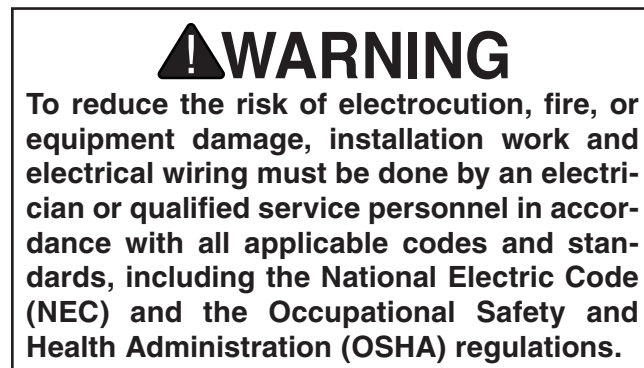

SECTION 3: SETUP

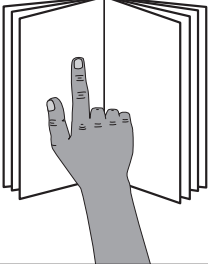

!WARNING
This machine presents serious injury hazards to untrained users. Read through this entire manual to become familiar with the controls and operations before starting the machine!



!WARNING
Wear safety glasses during the entire setup process!



!WARNING
HEAVY LIFT!
Straining or crushing injury may occur from improperly lifting machine or some of its parts. To reduce this risk, get help from other people and use a forklift (or other lifting equipment) rated for weight of this machine.

!WARNING
Like all machinery there is potential danger when operating this machine. Accidents are frequently caused by lack of familiarity or failure to pay attention. Use this machine with respect and caution to lessen the possibility of operator injury. If normal safety precautions are overlooked or ignored, serious personal injury may occur.

Needed for Setup

The following items are needed, but not included, for the setup/assembly of this machine.

Description	Qty
• Straightedge	1
• Level	1
• Another Person for Lifting Help	1
• Square	1
• Safety Glasses (for each person)	1
• Dust Collection System	1
• 4" Dust Hose (length as needed)	1
• 4" Hose Clamp	1

Unpacking

This machine was carefully packaged for safe transport. When unpacking, separate all enclosed items from packaging materials and inspect them for shipping damage. ***If items are damaged, please call us immediately at (570) 546-9663.***

IMPORTANT: Save all packaging materials until you are completely satisfied with the machine and have resolved any issues between Grizzly or the shipping agent. *You MUST have the original packaging to file a freight claim. It is also extremely helpful if you need to return your machine later.*



!WARNING
SUFFOCATION HAZARD!
Keep children and pets away from plastic bags or packing materials shipped with this machine. Discard immediately.



Inventory

The following is a list of items shipped with your machine. Before beginning setup, lay these items out and inventory them.

If any non-proprietary parts are missing (e.g. a nut or a washer), we will gladly replace them; or for the sake of expediency, replacements can be obtained at your local hardware store.

- Moving Plate (Resaw) 1
- Lock Handle M8-1.25 x 44 (Resaw)..... 1
- Flat Washer 8mm (Resaw) 1
- Hex Wrenches 3, 4, 5mm 1 Each

Main Components (Figure 3)		Qty
A.	Stand	1
B.	Bandsaw Unit	1
C.	Trunnion Base	1
D.	Lever Board.....	1
E.	Miter Gauge.....	1
F.	Extension Table.....	1
G.	Main Table.....	1
H.	Fence Assembly.....	1
I.	Resaw Fence	1
J.	Front Fence Rail.....	1
K.	Rear Fence Rail	1

Fasteners and Tools (not shown)		Qty
•	Rubber Feet (Stand)	4
•	Hex Nuts 3/8-16 (Feet/Stand)	8
•	Flat Washers 10mm (Feet/Stand)	8
•	Hex Bolts M8-1.25 x 35 (Bandsaw/Stand) .	4
•	Flat Washers 8mm (Bandsaw/Stand)	8
•	Lock Washers 8mm (Bandsaw/Stand).....	4
•	Hex Nuts M8-1.25 (Bandsaw/Stand).....	4
•	Hex Bolts M8-1.25 x 30 (Trunnion Base)...	2
•	Lock Washers 8mm (Trunnion Base).....	2
•	Hex Bolt M8-1.25 x 80 (Positive Stop).....	1
•	Hex Nut M8-1.25 (Positive Stop)	1
•	Spacers (Lever Board)	4
•	Cap Screws M8-1.25 x 60 (Lever Board) ..	4
•	Hex Nuts M8-1.25 (Lever Board)	4
•	Set Screws M8-1.25 x 20 (Lever Board)....	4
•	Cap Screws M6-1 x 25 (Lever Board)	4
•	Lock Washers 6mm (Lever Board)	4
•	Flat Washers 6mm (Lever Board)	4
•	Knobs M10-1.5 (Table)	2
•	Hex Bolts M6-1 x 20 (Front Rail)	2
•	Flat Washers 6mm (Front Rail).....	2
•	Lock Washers 6mm (Front Rail)	2
•	Cap Screws M6-1 x 16 (Rear Rails)	2
•	Lock Handle M8-1.25 x 20 (Fence).....	1
•	Hex Nut M8-1.25 (Fence).....	1

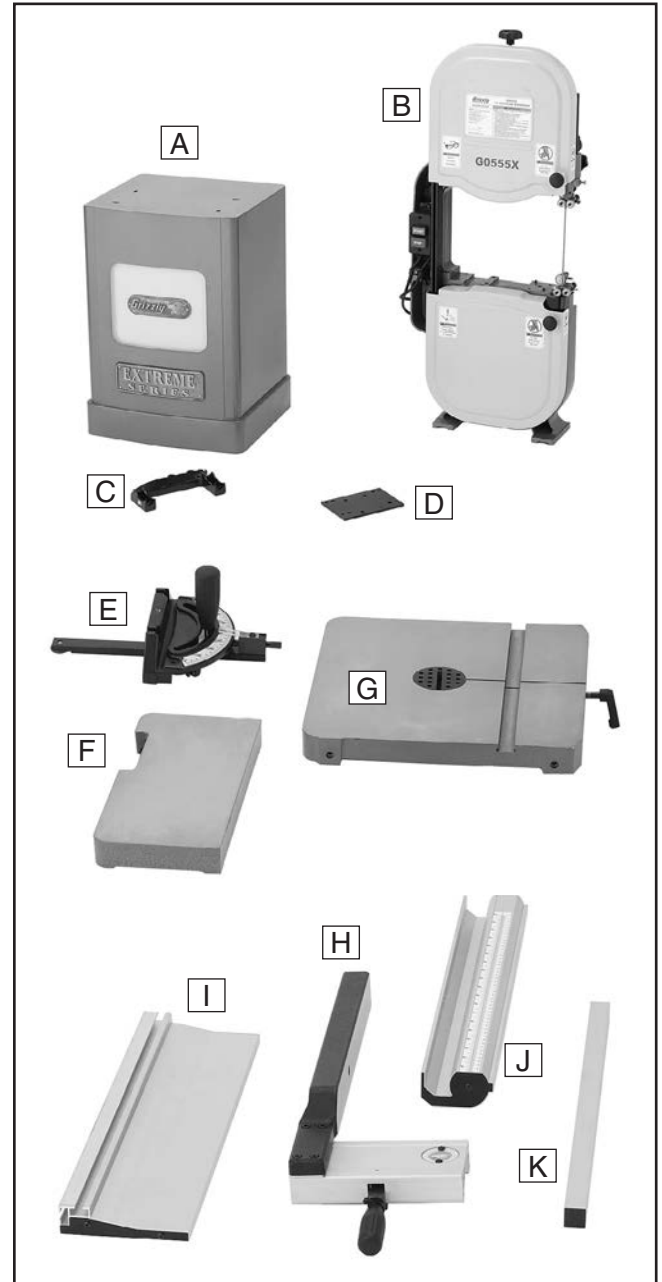

Figure 3. Main components inventory.

NOTICE

If you cannot find an item on this list, carefully check around/inside the machine and packaging materials. Often, these items get lost in packaging materials while unpacking or they are pre-installed at the factory.



Hardware Recognition Chart

USE THIS CHART TO MATCH UP
HARDWARE DURING THE INVENTORY
AND ASSEMBLY PROCESS.

MEASURE BOLT DIAMETER BY PLACING INSIDE CIRCLE

#10

1/4"

5/16"

3/8"

7/16"

1/2"



Key

4mm

5mm

6mm

8mm

10mm

12mm

16mm

LINES ARE 1MM APART

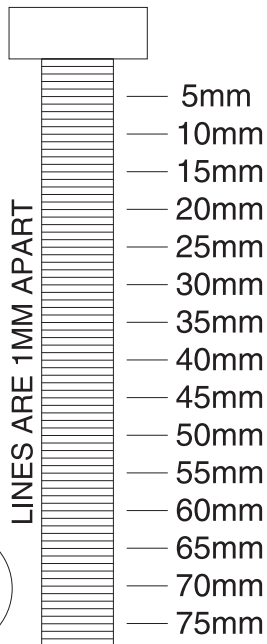

LINES ARE 1/16" INCH APART

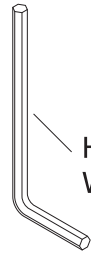
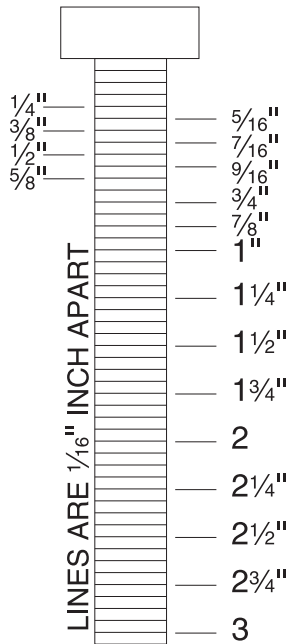

Hex Wrench

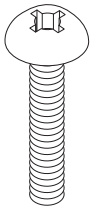

Phillips Head Screw

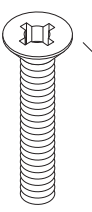

Flat Head Screw

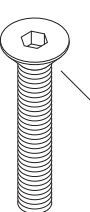

Flat Head Cap Screw

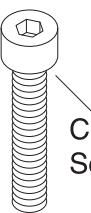

Cap Screw

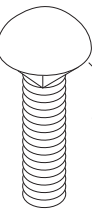

Carriage Bolt

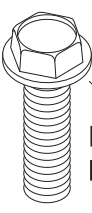

Flange Bolt

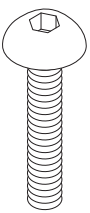

Button Head Screw



Tap Screw



External Retaining Ring



Internal Retaining Ring



E-Clip

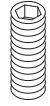

Set Screw

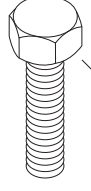

Hex Bolt



Lock Nut



Wing Nut

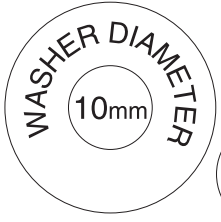
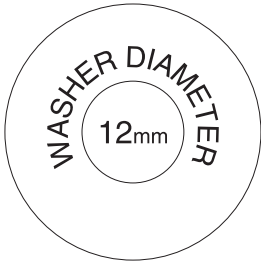
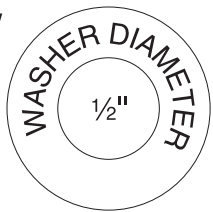
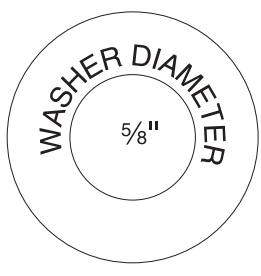

WASHERS ARE MEASURED BY THE INSIDE DIAMETER



Cleanup

The unpainted surfaces of your machine are coated with a heavy-duty rust preventative that prevents corrosion during shipment and storage. This rust preventative works extremely well, but it will take a little time to clean.

Be patient and do a thorough job cleaning your machine. The time you spend doing this now will give you a better appreciation for the proper care of your machine's unpainted surfaces.

There are many ways to remove this rust preventative, but the following steps work well in a wide variety of situations. Always follow the manufacturer's instructions with any cleaning product you use and make sure you work in a well-ventilated area to minimize exposure to toxic fumes.

Before cleaning, gather the following:

- Disposable rags
- Cleaner/degreaser (WD•40 works well)
- Safety glasses & disposable gloves
- Plastic paint scraper (optional)

Basic steps for removing rust preventative:

1. Put on safety glasses.
2. Coat the rust preventative with a liberal amount of cleaner/degreaser, then let it soak for 5–10 minutes.
3. Wipe off the surfaces. If your cleaner/degreaser is effective, the rust preventative will wipe off easily. If you have a plastic paint scraper, scrape off as much as you can first, then wipe off the rest with the rag.
4. Repeat **Steps 2–3** as necessary until clean, then coat all unpainted surfaces with a quality metal protectant to prevent rust.

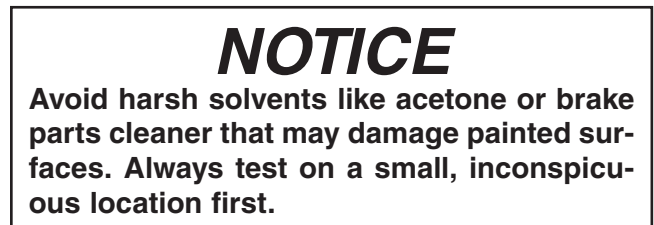
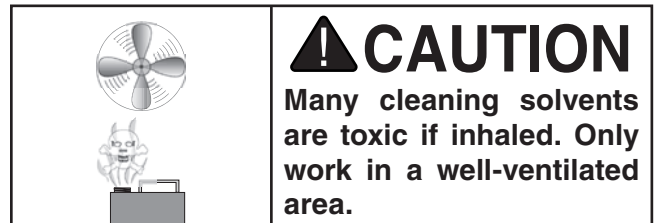
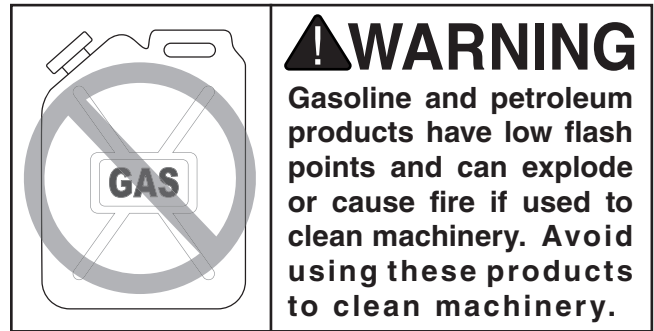

T23692—Orange Power Degreaser

A great product for removing the waxy shipping grease from the *non-painted* parts of the machine during clean up.



Figure 4. T23692 Orange Power Degreaser.



Site Considerations

Weight Load

Refer to the **Machine Data Sheet** for the weight of your machine. Make sure that the surface upon which the machine is placed will bear the weight of the machine, additional equipment that may be installed on the machine, and the heaviest workpiece that will be used. Additionally, consider the weight of the operator and any dynamic loading that may occur when operating the machine.

Space Allocation

Consider the largest size of workpiece that will be processed through this machine and provide enough space around the machine for adequate operator material handling or the installation of auxiliary equipment. With permanent installations, leave enough space around the machine to open or remove doors/covers as required by the maintenance and service described in this manual.

See below for required space allocation.



Physical Environment

The physical environment where the machine is operated is important for safe operation and longevity of machine components. For best results, operate this machine in a dry environment that is free from excessive moisture, hazardous chemicals, airborne abrasives, or extreme conditions. Extreme conditions for this type of machinery are generally those where the ambient temperature range exceeds 41°–104°F; the relative humidity range exceeds 20%–95% (non-condensing); or the environment is subject to vibration, shocks, or bumps.

Electrical Installation

Place this machine near an existing power source. Make sure all power cords are protected from traffic, material handling, moisture, chemicals, or other hazards. Make sure to leave enough space around machine to disconnect power supply or apply a lockout/tagout device, if required.

Lighting

Lighting around the machine must be adequate enough that operations can be performed safely. Shadows, glare, or strobe effects that may distract or impede the operator must be eliminated.

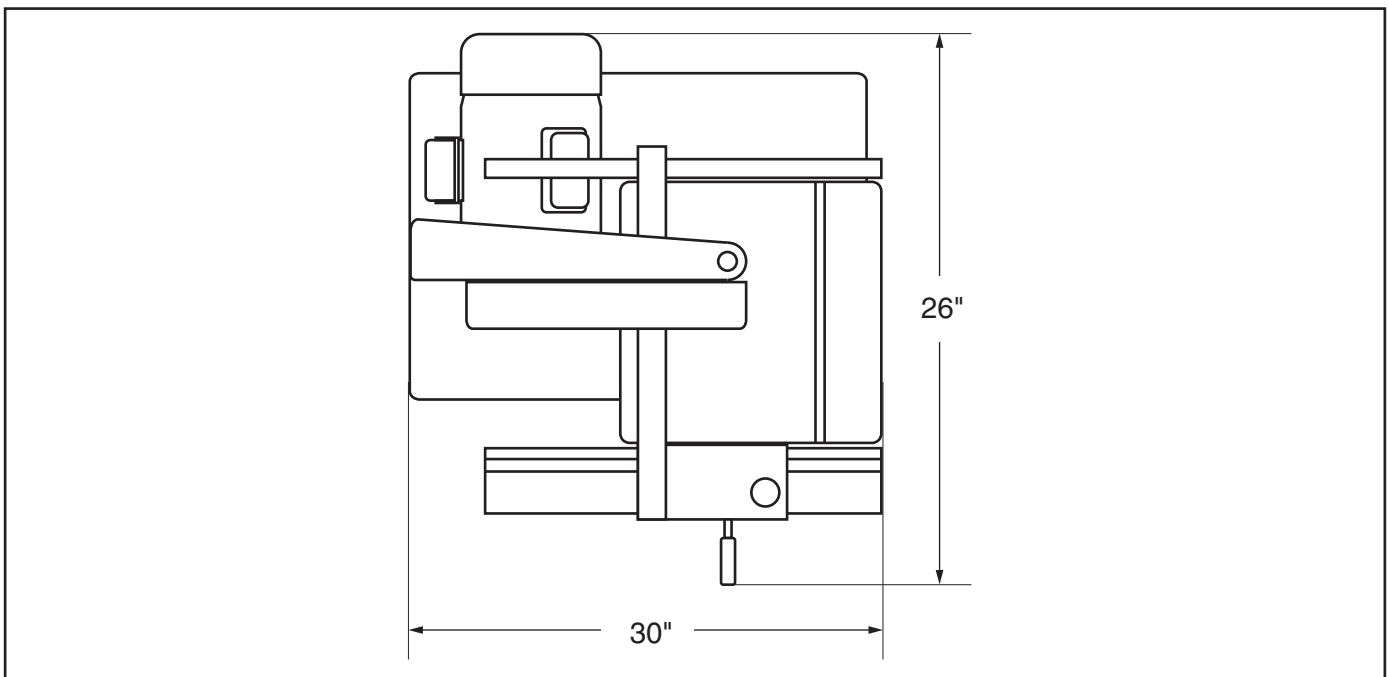

Figure 5. Minimum working clearances.



Assembly

The machine must be fully assembled before it can be operated. Before beginning the assembly process, refer to **Needed for Setup** and gather all listed items. To ensure the assembly process goes smoothly, first clean any parts that are covered or coated in heavy-duty rust preventative (if applicable).

To assemble bandsaw:

1. Install rubber feet into bottom of cabinet stand, as shown in **Figure 6**, with $\frac{3}{8}$ -16 hex nuts and 10mm flat washers.

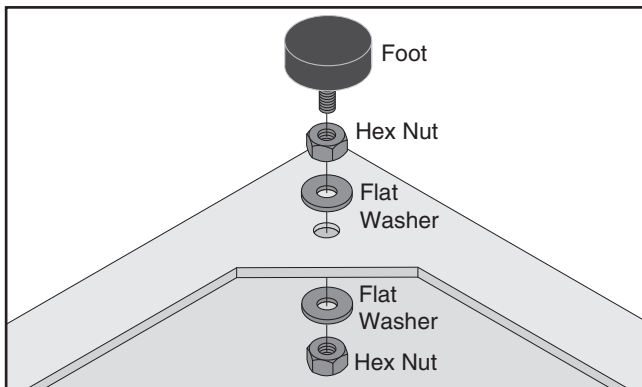
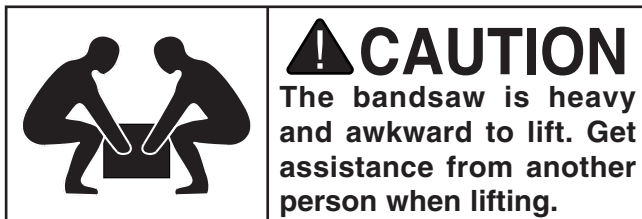

Figure 6. Rubber foot order of installation.

2. Level cabinet stand by adjusting feet up or down, then tighten hex nuts against stand to secure feet in place.



3. Get an assistant to help you lift the bandsaw and place it on top of the stand.
4. Line up mounting holes on bandsaw base with those on stand.
5. Secure bandsaw to stand with (4) M8-1.25 x 35 hex bolts, (8) 8mm flat washers, (4) 8mm lock washers, and (4) M8-1.25 hex nuts (see **Figure 7**).



Figure 7. Bandsaw mounted to stand.

6. Fasten trunnion base to bandsaw, as shown in **Figure 8**, with (2) M8-1.25 x 30 hex bolts and (2) 8mm lock washers.

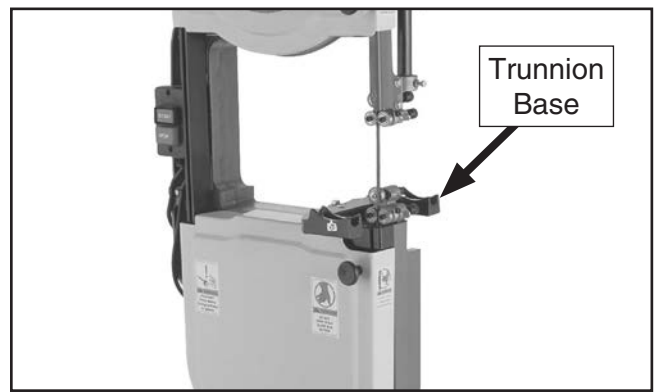

Figure 8. Installing trunnion base.

7. Thread (1) M8-1.25 hex nut halfway up M8-1.25 x 80 hex bolt.
8. Thread the M8-1.25 x 80 hex bolt (a.k.a. positive stop bolt) into trunnion base so it is installed similar to **Figure 9**.

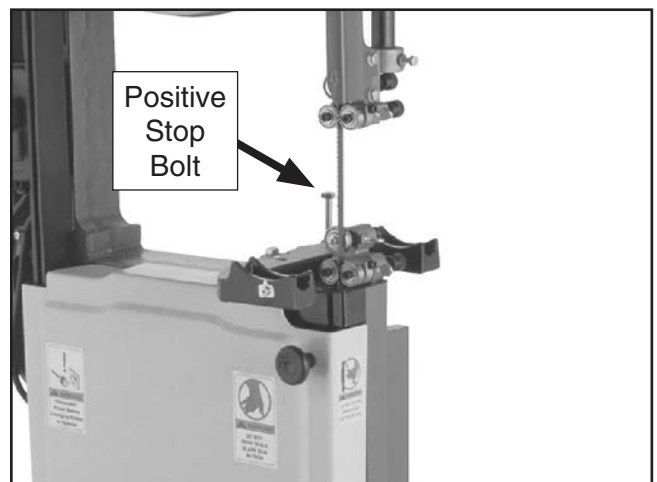

Figure 9. Shows positive stop bolt installed.



- Attach lever board to bandsaw body with (4) spacers and (4) M8-1.25 x 60 cap screws, as shown in **Figure 10**.

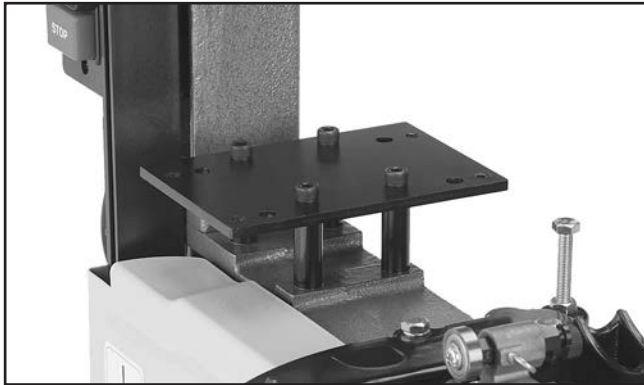

Figure 10. Lever body attached.

- Thread four set screws into lever board from underneath until they are flush with top of lever board (see **Figure 11**), then thread M8-1.25 hex nuts up set screws and against lever board.

Note: *The hex nuts act to lock the set screws in place once they are positioned, so they do not vibrate loose during operation.*

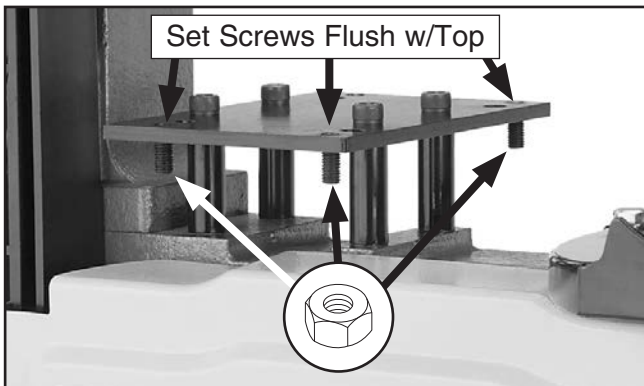

Figure 11. Set screws installed in lever board (3 of 4 shown).

- Attach extension table to lever board with (4) M6-1 x 25 cap screws, (4) 6mm flat washers, and (4) 6mm lock washers (see **Figure 12**). Only thread cap screws in halfway for now (adjustments to extension table will be made later).

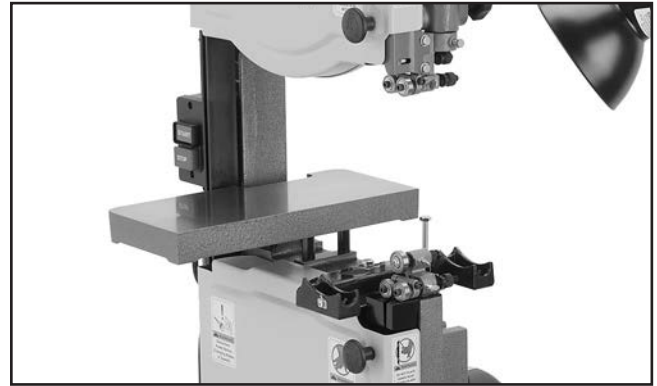

Figure 12. Extension table installed.

- Remove table insert from center of table and remove table pin from end of table slot.
- Fit table around blade and rest table trunnions on trunnion base, making sure trunnion bolts are hanging out of bottom of trunnion base.
- Thread (2) M10-1.5 knobs onto the trunnion bolts hanging through bottom of trunnion base, as illustrated in **Figure 13**.

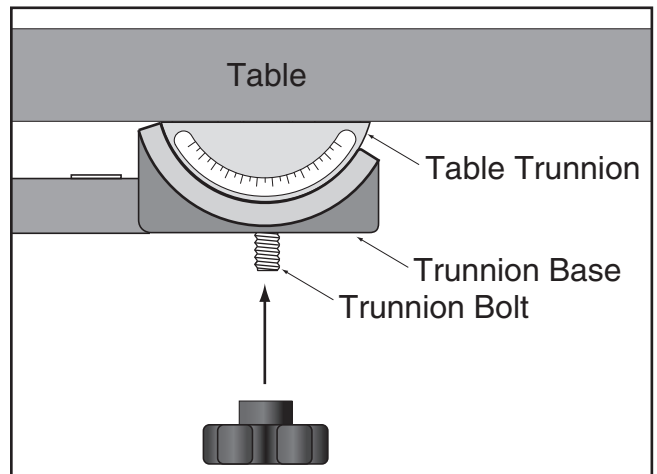

Figure 13. Table installation on trunnion base.

- Place table insert in center of table, so it sits flush with table top surface.
- Insert pin into end of table slot.



17. Fasten front fence rail to front of bandsaw table with (2) M6-1 x 20 hex bolts, (2) 6mm lock washers, and (2) 6mm flat washers, as shown in **Figure 14**.



Figure 14. Fastening front fence rail to table.

18. Fasten rear fence rail to back of bandsaw with (2) M6-1 x 16 cap screws.
19. Thread M8-1.25 hex nut from hardware bag onto fence handle threads, then thread fence handle into fence.
20. Tighten hex nut (already on the fence handle threads) down to fence body to keep fence handle from rotating.
21. Pull fence handle up and place fence on the front fence rail, as shown in **Figure 15**.

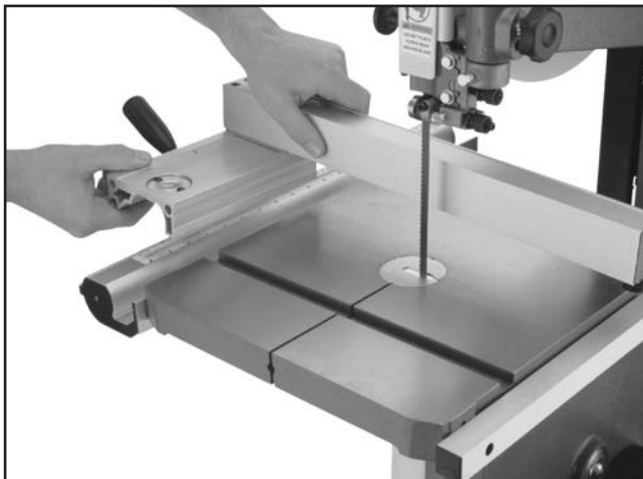

Figure 15. Installing fence onto rails.

22. Push fence handle down to lock fence in position.
23. Insert lock handle with washer through hole in fence and attach moving plate (see **Figure 16**) on other side.
24. Slide resaw fence over moving plate as shown in **Figure 16**. Center it with original fence, then lock it in position by tightening lock handle.

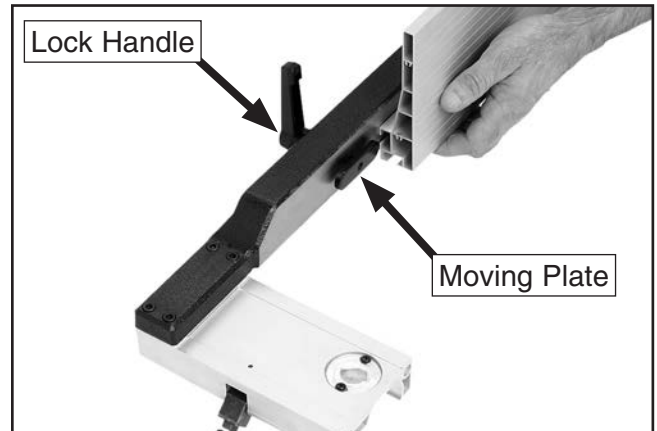

Figure 16. Installing resaw fence.

25. Install a light bulb that is rated for the wired voltage of the machine. The bulb must not exceed 60W.



Dust Collection

⚠ CAUTION

This machine creates a lot of wood chips/dust during operation. Breathing airborne dust on a regular basis can result in permanent respiratory illness. Reduce your risk by wearing a respirator and capturing the dust with a dust-collection system.

Recommended CFM at Dust Port: 400 CFM

Do not confuse this CFM recommendation with the rating of the dust collector. To determine the CFM at the dust port, you must consider these variables: (1) CFM rating of the dust collector, (2) hose type and length between the dust collector and the machine, (3) number of branches or wyes, and (4) amount of other open lines throughout the system. Explaining how to calculate these variables is beyond the scope of this manual. Consult an expert or purchase a good dust collection "how-to" book.

To connect dust collection system to machine:

1. Fit 4" dust hose over dust port, as shown in **Figure 17**, and secure in place with a hose clamp.
2. Tug hose to make sure it does not come off.

Note: A tight fit is necessary for proper performance.

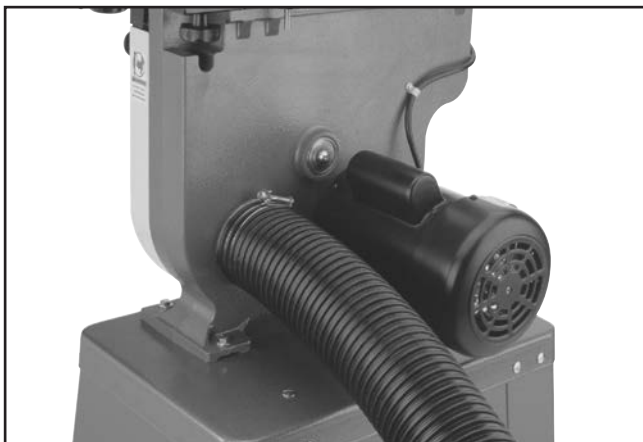

Figure 17. Dust hose attached to dust port.

Adjustment Overview

The bandsaw is one of the most versatile wood-working machines. However, it has multiple components that must be properly adjusted for the best cutting results.

For practical and safety reasons, some adjustments and test operations must be performed before performing other necessary adjustments. Below is an overview of all the adjustments and the order in which they should be performed:

1. Initial Blade Tracking
2. Test Run
3. Tension Blade
4. Adjusting Blade Support Bearings
5. Adjusting Blade Guide Bearings
6. Table Tilt Calibration
7. Aligning Table
8. Aligning Fence

Initial Blade Tracking

"Tracking" refers to how the blade rides on the bandsaw wheels. Proper tracking is important for maintaining bandsaw adjustments, achieving correct blade tension, and cutting accurately. Improper tracking reduces cutting accuracy, causes excess vibrations, and places stress on the blade and other bandsaw components. The shape of the wheels and the orientation of the wheels in relation to each other determine how the blade tracks.

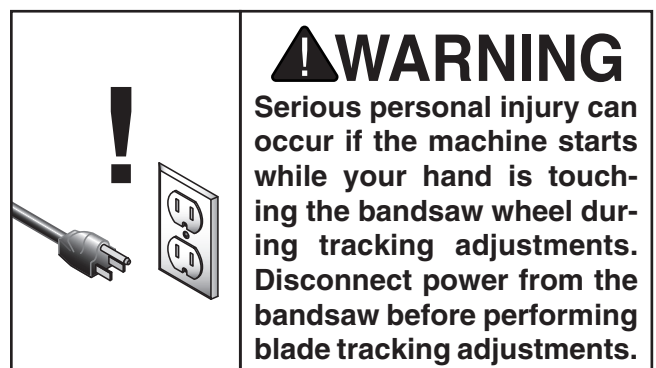

Bandsaw wheels are either flat or crowned and both shapes track differently. This bandsaw has crowned wheels. As the wheels spin, a properly tracking blade naturally tracks at the center of the wheel (see **Figure 18**).

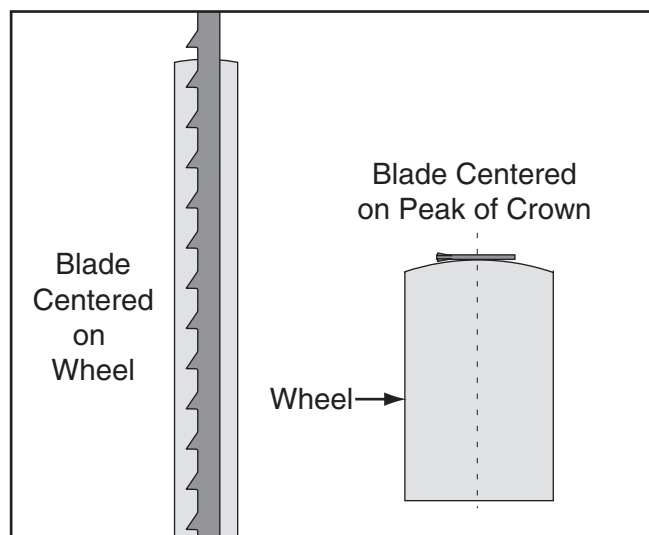

Figure 18. Blade centered on crown of wheel.

Blade tracking is primarily affected by the tilt of the upper wheel, known as “center tracking.” However, the alignment of both wheels plays an important part as well (see **Wheel Alignment** on **Page 50** for more details).

The wheels on this bandsaw were aligned at the factory, so center tracking is the only adjustment that needs to be checked/performed when the saw is new.

To set blade center tracking:

1. DISCONNECT MACHINE FROM POWER!
2. Adjust upper and lower blade guides away from blade (refer to **Adjusting Blade Guide Bearings** on **Page 25** for detailed instructions).

Note: When adjusting blade tracking for test run in this procedure, blade must have a reasonable amount of tension to simulate operating conditions. After test run is successfully completed, you will perform a thorough version of the following steps to more accurately tension the blade.

3. Pull blade tension quick-release lever down (as viewed from rear of machine) to apply tension to blade (see **Figure 19**).
4. Use tension knob on top of the bandsaw to bring upper edge of indicator block to appropriate blade tension scale mark for blade width (see **Figure 19**).

Note: A $\frac{3}{8}$ " wide blade is shipped with the machine when new.

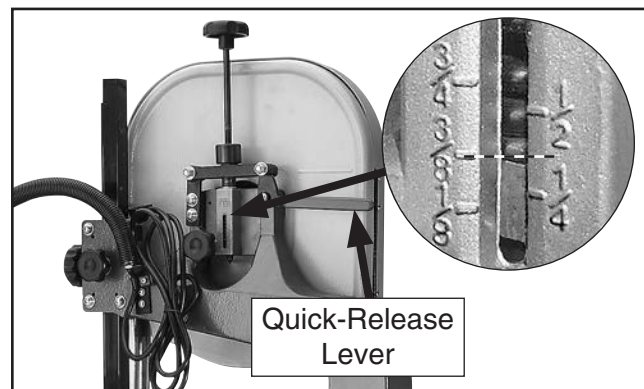

Figure 19. Tension applied for a $\frac{3}{8}$ " blade.

5. Open upper wheel cover, rotate upper wheel by hand several times and watch where blade rides on wheel crown (see **Figure 18** for an illustration of this concept).

—If blade rides in center of upper wheel and is centered on wheel crown, it is properly tracking and you are done with this procedure—proceed to **Test Run** on **Page 22**.

—If blade is NOT properly tracking, then continue with this procedure to adjust it.

6. Loosen wing nut on tracking knob (see **Figure 20**).

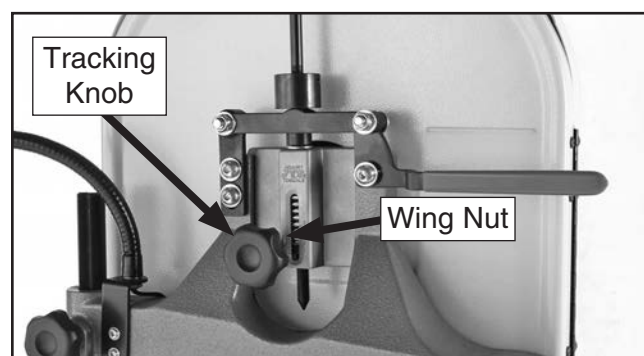

Figure 20. Tracking knob and wing nut for blade tracking controls.



7. Spin upper wheel with one hand and slowly adjust tracking knob with other hand until blade consistently tracks in center of wheel.
8. Tighten wing nut to lock setting, then spin upper wheel several times to confirm proper tracking. If necessary, repeat adjustment procedure until blade is tracking properly.
9. Re-adjust blade guide bearings toward blade (refer to **Adjusting Blade Guide Bearings** on **Page 25** for detailed instructions).
10. Close and secure upper wheel cover before operating bandsaw.

Test Run

Once assembly is complete, test run the machine to ensure it is properly connected to power and safety components are functioning correctly.

If you find an unusual problem during the test run, immediately stop the machine, disconnect it from power, and fix the problem **BEFORE** operating the machine again. The **Troubleshooting** table in the **SERVICE** section of this manual can help.

The Test Run consists of verifying the following:
 1) The motor powers up and runs correctly, and
 2) the safety disabling mechanism on the switch works correctly.

!WARNING

Serious injury or death can result from using this machine BEFORE understanding its controls and related safety information. DO NOT operate, or allow others to operate, machine until the information is understood.

!WARNING

DO NOT start machine until all preceding setup instructions have been performed. Operating an improperly set up machine may result in malfunction or unexpected results that can lead to serious injury, death, or machine/property damage.

To test run machine:

1. Clear all setup tools away from machine.
2. Connect machine to power supply.
3. Turn machine **ON**, verify motor operation, and then turn machine **OFF**.

The motor should run smoothly and without unusual problems or noises.

4. Insert disabling pin or padlock through switch button (see **Figure 21**).

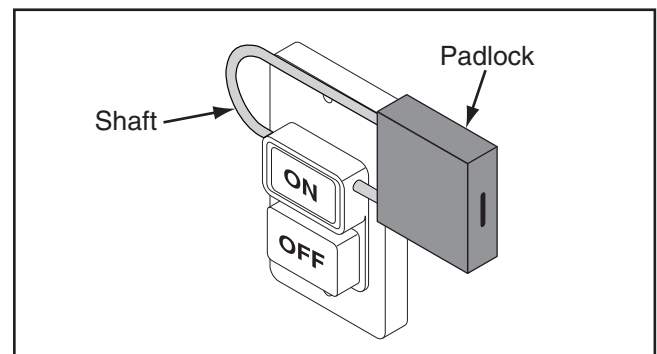

Figure 21. Switch disabling padlock inserted into ON button.

5. Try to start machine by pressing switch button.

Machine should **NOT** start. If it does start, the switch disabling feature is not functioning properly and the switch must be replaced.



Tensioning Blade

A properly tensioned blade is essential for making accurate cuts, maximizing blade life, and making other bandsaw adjustments. However, a properly tensioned blade will not compensate for cutting problems caused by excessive feed rate, hardness variations between workpieces, and improper blade selection.

Optimal cutting results for any type of workpiece are achieved through a combination of correct blade selection, proper blade tension, properly adjusted blade guides and other bandsaw components, and using an appropriate feed rate.

Improper blade tension is unsafe, produces inaccurate and inconsistent results, and introduces unnecessary wear on bandsaw components. Over-tensioning the blade increases the chance of the blade breaking or wheel misalignment. Under-tensioned blades wander excessively while cutting and will not track properly during operation.

The method used to tension the blade is often a matter of preference. This manual describes two methods: the flutter method and the deflection method. Either method will help you properly tension the blade. Experience and personal preference will help you decide which method you prefer.

Note: *Tensioning the blade before the **Test Run** was an approximate tension. The following procedures fine-tune the blade tension.*

The Flutter Method

Using the flutter method, you intentionally loosen the blade until it just passes the point of being too loose (when it begins to flutter). Then you gradually tighten the blade until proper tension is reached.

To tension bandsaw blade using flutter method:

1. DISCONNECT MACHINE FROM POWER.
2. Make sure blade is properly center tracking (refer to **Blade Tracking** on **Page 20** for instructions).
3. Raise guide post all the way up and move upper and lower guide bearings away from blade (refer to **Adjusting Blade Guide Bearings** on **Page 25**).
4. Engage blade tension quick release lever to apply tension to blade.
5. Connect bandsaw to power, and turn bandsaw **ON**.
6. Using blade tension adjustment knob, slowly decrease blade tension until you see the blade start to flutter.
7. Slowly increase tension until blade stops fluttering, then tighten blade tension adjustment knob and additional $\frac{1}{8}$ to $\frac{1}{4}$ turn.
8. View tension gauge and use that as a guide for tensioning that specific blade size in the future.

Note: *Do not rely on this setting for other blades or for long periods of time because all blades require specific tensioning and stretch with use. If you notice a decrease in performance at the setting repeat this procedure.*

*With extended use, blade tensioning system may need to be reset. Refer to **Resetting Blade Tensioner** in the **Service** section in this manual for details.*

9. Disconnect bandsaw from power.
10. Re-adjust blade guides (refer to **Adjusting Blade Support Bearings** and **Adjusting Blade Guide Bearings** on **Pages 24–25** for instructions).



The Deflection Method

The deflection method is much more subjective than the flutter method. Each blade will deflect differently and every user will determine what "moderate pressure" means. The following are general guidelines for tensioning the blade with this method.

To tension bandsaw blade using deflection method:

1. DISCONNECT MACHINE FROM POWER.
2. Make sure blade is properly tracking (refer to **Initial Blade Tracking** on **Page 20** for instructions).
3. Raise guide post all the way up and move upper and lower guide bearings away from the blade.
4. Set blade tension quick release lever to apply tension to the blade.
5. Using moderate pressure, push the center of blade sideways.

—If blade deflects approximately $\frac{1}{4}$ " it is properly tensioned. Proceed to **Step 7**.

—If blade deflects less than $\frac{1}{4}$ " it is over-tensioned. Turn blade tensioning knob counter clockwise two full turns and repeat **Step 6**.

—If the blade deflects $\frac{1}{4}$ " or more, it is under-tensioned. Apply tension to blade incrementally and repeat **Step 6** until properly tensioned.

6. Re-adjust blade guides (refer to **Adjusting Blade Support Bearings** and **Adjusting Blade Guide Bearings** beginning on this page for instructions).

NOTICE

When using different size blades, the blade tensioning system may need to be reset for correct operation.

Adjusting Blade Support Bearings

The support bearings are positioned behind the blade on the blade guides and prevent it from deflecting backward during cutting operations. Proper adjustment of the support bearings is an important part of making accurate cuts and keeps the blade teeth from coming in contact with the blade guides while cutting, which will bend the "tooth set" of the blade teeth and ruin the cutting effectiveness of the blade.

There are support bearings on the upper and lower blade guide assemblies. Both adjust in the same manner.

IMPORTANT: Make sure the blade is tracking and tensioned correctly before performing this procedure.

Items Needed	Qty
Wrench 10mm	1
Feeler Gauge 0.016" (or Dollar Bill)	1

To adjust support bearings:

1. DISCONNECT MACHINE FROM POWER!
2. Familiarize yourself with support bearing controls shown in **Figure 22**.

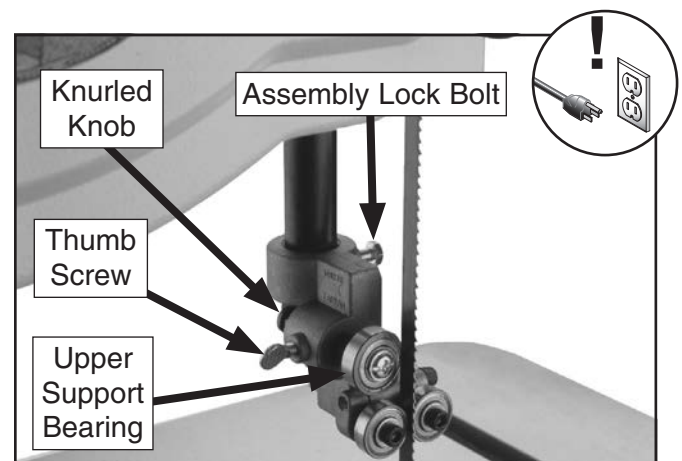

Figure 22. Support bearing controls.



3. Loosen guide assembly lock bolt (see **Figure 22**) so that support bearing can be rotated perpendicular to blade in next step.
4. Rotate blade guide assembly until the face of support bearing is perpendicular to blade, as shown in **Figure 23**.

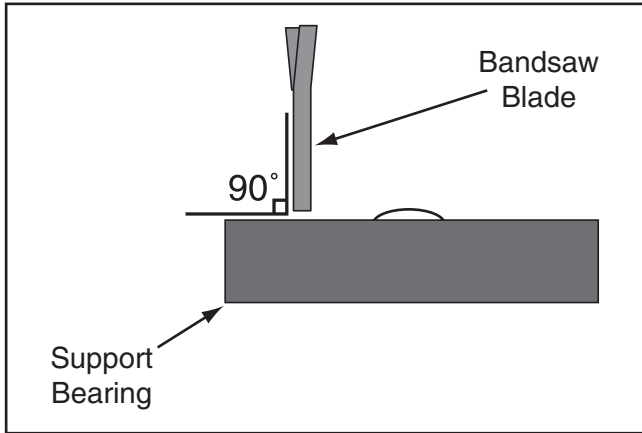

Figure 23. The face of the support bearing must be perpendicular (90°) to the blade.

5. Tighten assembly lock bolt (see **Figure 22** on **Page 24**).
6. Loosen thumb screw (see **Figure 22** on **Page 24**) on support bearing adjustment shaft.
7. Use knurled knob to position support bearing approximately 0.016" away from back of blade, as shown in **Figure 24**. Measure this with a feeler gauge or a dollar bill folded twice.

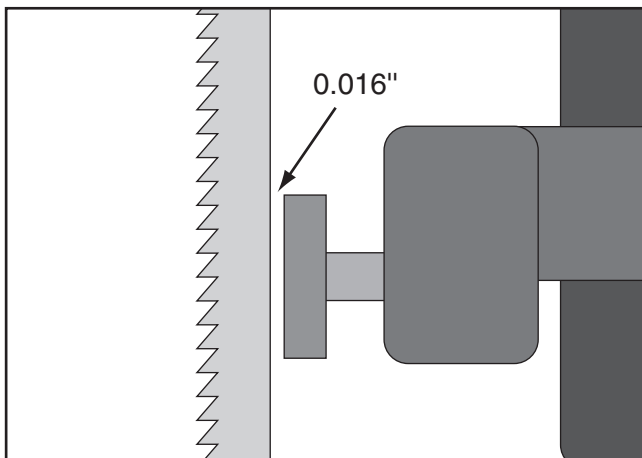

Figure 24. Blade should be aligned approximately 0.016" away from the bearing edge.

8. Tighten thumb screw to secure adjustment.

Adjusting Blade Guide Bearings

Properly adjusting the blade guides provides side-to-side support to help keep the blade straight while cutting.

There are blade guide bearings on the upper and lower blade guide assemblies. Both adjust in the same manner.

IMPORTANT: Ensure the blade is tracking and tensioned correctly before performing this procedure (see **Tensioning Blade** on **Page 23**).

Items Needed	Qty
Hex Wrench 4mm.....	2

To adjust upper and lower blade guides:

1. DISCONNECT MACHINE FROM POWER!
2. Familiarize yourself with blade guide controls shown in **Figure 25**.
3. Loosen thumbscrew on forward/backward adjustment rod.

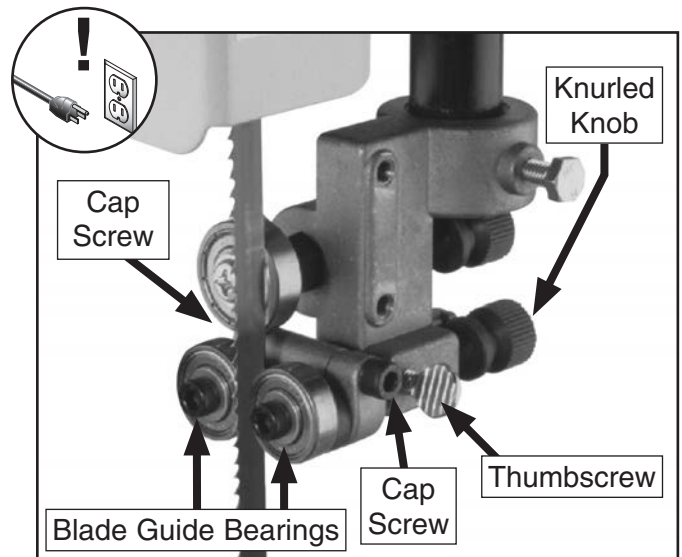

Figure 25. Blade guide controls.

4. Rotate knurled knob behind blade guides to position blade guides laterally, so front edges of bearings are just behind blade gullets, as illustrated in **Figure 26** on **Page 26**.



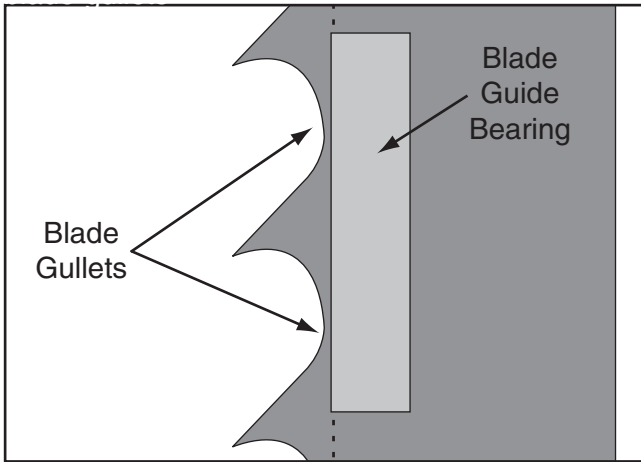

Figure 26. Lateral adjustment of blade guides.

NOTICE

Make sure that the blade teeth will not contact the guide bearings when the blade is against the rear support bearing during the cut.

5. Tighten thumbscrew on lateral adjustment rod so knurled knob will not turn.
6. Loosen cap screws behind blade guides.
7. With a hex wrench, rotate cap screws in center portion of blade guides while slowing rotating blade wheel. Adjust till bearing is engaged by blade, back off adjustment till the bearing stops moving as the blade passes (see **Figure 27**).

When blade guide bearings are properly positioned just of contact, they rotate only slightly when the bandsaw wheel is turned.

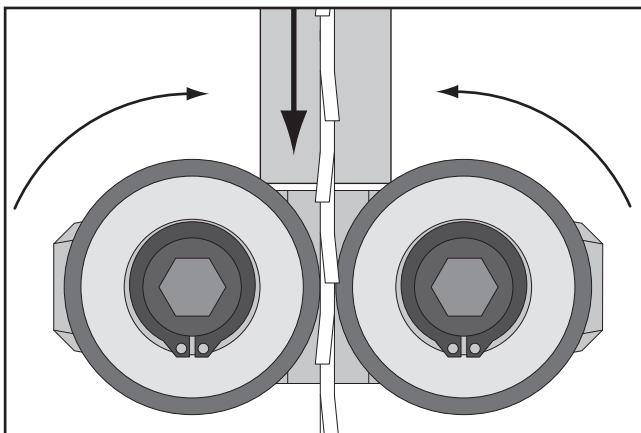

Figure 27. Blade guide bearings against both sides of blade.

8. Tighten cap screws to lock blade guides in position.

NOTICE

Whenever changing a blade or adjusting tension and tracking, the upper and lower blade guide bearings and blade guide bearings must be re-adjusted before cutting operations.

Adjusting Positive Stop

An adjustable positive stop allows the table to easily return to 90° after tilting.

To set positive stop 90° to blade:

1. Make sure blade is correctly tensioned as described in **Tensioning Blade** instructions on **Page 23**.
2. DISCONNECT BANDSAW FROM POWER!
3. Loosen two plastic knobs that secure table to trunnions.
4. Loosen hex nut that locks positive stop bolt in place.
5. Raise upper blade guide assembly and place a 6" machinist's square or try-square on table next to side of the blade as illustrated in **Figure 28**. Adjust positive stop bolt to raise or lower table until table is 90° to blade.



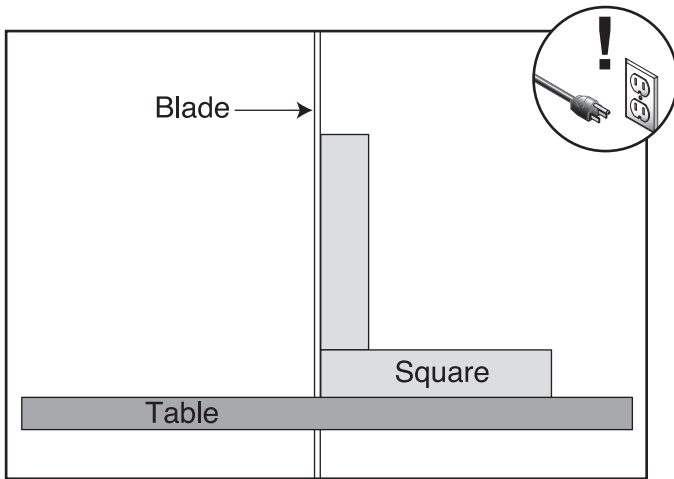

Figure 28. Squaring table to blade.

- Secure plastic knobs and lock positive stop bolt by tightening hex nut against casting. *Ensure bolt does not turn by holding with another wrench while tightening hex nut.*

Setting Table Tilt Scale to 0°

The pointer on the table tilt scale must be calibrated in order for the scale reading to be accurate.

To calibrate pointer on table tilt scale:

- Make sure blade is tensioned and is tracking correctly, and that table is 90° to blade (this procedure should be already completed with **Adjusting Positive Stop** instructions).
- Loosen screw on pointer so pointer is able to move.
- Align tip of pointer with the 0° mark on table tilt scale.
- Tighten screw on the pointer so pointer is locked in place.

Leveling Extension Table

The extension table must be level with the main table. It is important to keep the extension table at least 1/8" away from the main table during leveling to allow the table room for tilting.

To level extension table:

- Set table to 90°.
- Locate lever board set screws underneath extension table (see **Figure 11** on **Page 18**) and loosen hex nuts on set screws. This will allow you to adjust set screws when leveling extension table.
- Place a straightedge across the front of the main table and extension table as shown in **Figure 29**.

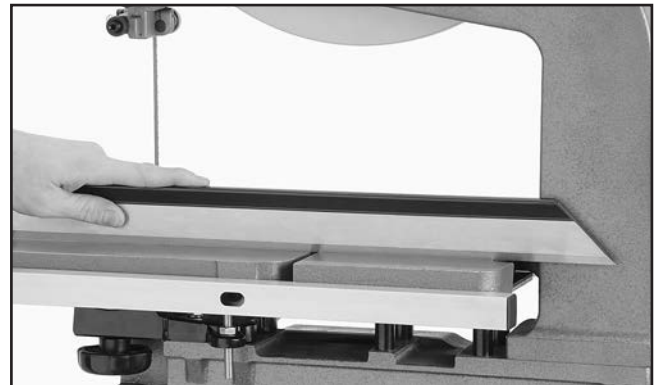

Figure 29. Leveling extension table with straightedge.



4. Adjust two front set screws in lever board until extension table is even with main table.
 5. Place a straightedge across the rear of the main table and extension table.
 6. Adjust two front set screws in lever board until extension table is even with main table.
 7. Repeat **Steps 3–4**.
 8. Repeat **Steps 5–6**.
 9. Tighten cap screws that secure extension table to lever board.
 10. Verify that extension table did not move during tightening and adjust if necessary.
 11. Tighten hex nuts loosened in **Step 2** against lever board so set screws cannot vibrate out of adjustment.
3. Loosen trunnion bolts that secure trunnions to table.
 4. Place an accurate straightedge along the blade. The straightedge should lightly touch both front and back of blade.
 5. Use a fine ruler to gauge distance between blade and miter slot. The distance you measure should be the same at front and back ends of miter slot.
 6. Adjust table as needed until distance between the blade and miter slot is equal at both ends, as measured in **Step 5**.
 7. Tighten trunnion bolts.

CAUTION

No list of safety guidelines can be complete. Every shop environment is different. Always consider safety first, as it applies to your individual working conditions. Use this and other machinery with caution and respect. Failure to do so could result in serious personal injury, damage to equipment, or poor work results.

Aligning Table

To ensure cutting accuracy when the table is first installed, the table should be aligned so the miter slot is parallel to the bandsaw blade. *This procedure works best with a 3/4" blade.*

To align miter slot parallel to bandsaw blade:

1. Make sure blade is tracking properly and that it is correctly tensioned.
2. **DISCONNECT BANDSAW FROM POWER!**

Aligning Fence

To ensure cutting accuracy, the fence must be parallel with the miter slot.

To align fence parallel with miter slot:

1. If fence is mounted on left-hand side of blade, remove it and remount it on the right-hand side of the blade.
2. Loosen four cap screws located on top face of fence.
3. Adjust fence face parallel with edge of miter slot.
4. Tighten four cap screws, being careful not to move the fence.

NOTICE

Adjusting the fence parallel to the miter slot does not guarantee straight cuts. The miter slot may need to be adjusted parallel to the side of the blade. Refer to the Aligning Table instructions.





SECTION 4: OPERATIONS

Operation Overview

The purpose of this overview is to provide the novice machine operator with a basic understanding of how the machine is used during operation, so the machine controls/components discussed later in this manual are easier to understand.

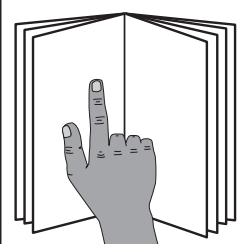
Due to the generic nature of this overview, it is **not** intended to be an instructional guide. To learn more about specific operations, read this entire manual, seek additional training from experienced machine operators, and do additional research outside of this manual by reading "how-to" books, trade magazines, or websites.

	<p>!WARNING To reduce the risk of serious injury when using this machine, read and understand this entire manual before operating.</p>
--	---

<p>!WARNING Damage to your eyes and lungs could result from using this machine without proper protective gear. Always wear safety glasses and a respirator when operating this machine.</p>	
	

<p>NOTICE If you have never used this type of machine or equipment before, WE STRONGLY RECOMMEND that you read books, review industry trade magazines, or get formal training before beginning any projects. Regardless of the content in this section, Grizzly Industrial will not be held liable for accidents caused by lack of training.</p>

To complete a typical operation, the operator does the following:

1. Examines workpiece to make sure it is suitable for cutting.
 2. Adjusts fence for width of cut and then locks it in place.
 3. Adjusts table tilt, if necessary, to correct angle of desired cut.
 4. Loosens guide post lock knob, adjusts upper blade guide height to just clear workpiece (no more than 1/4"), then re-tightens guide post lock knob.
 5. Checks to make sure workpiece can safely pass all the way through blade without interference from other objects.
 6. Puts on safety glasses and a respirator.
 7. Starts dust collector and bandsaw.
 8. Firmly holds workpiece flat against both table and fence, and then pushes workpiece into blade at a steady and controlled rate until cut is complete.
- IMPORTANT:** *The operator is very careful to keep fingers away from the blade and uses a push stick to feed narrow workpieces.*
9. Stops bandsaw.



General Overview

The bandsaw is one of the most versatile wood cutting tools in the shop. It is capable of performing the following types of cuts:

Straight Cuts

- Miters
- Angles
- Compound Angles
- Resawing
- Ripping
- Crosscutting

Irregular Cuts

- Simple and Complex Curves
- Duplicate Parts
- Circles
- Beveled Curves

A properly adjusted bandsaw can be safer to operate than most other saws and performs many functions with ease and accuracy.

Basic Cutting Tips

Here are some basic tips to follow when operating the bandsaw:

- Replace, sharpen, and clean blades as necessary. Make adjustments periodically to keep the saw running in top condition.
- Use light and even pressure while cutting. Light contact with the blade eases line following and prevents undue friction.
- Avoid twisting the blade when cutting around tight corners. Allow the blade to saw around the corners.
- Misusing the saw or using incorrect techniques is unsafe and results in poor cuts. Remember—the blade does the cutting with the operator's guidance.

Disabling & Locking Switch

The ON/OFF switch can be disabled and locked by inserting a padlock through the ON button, as shown. Locking the switch in this manner can prevent unauthorized operation of the machine, which is especially important if the machine is not stored inside an access-restricted building.

IMPORTANT: Locking the switch with a padlock only restricts its function. It is not a substitute for disconnecting power from the machine when adjusting or servicing.

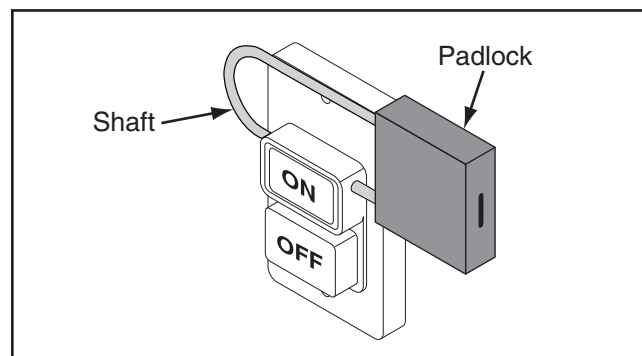

Figure 30. Switch disabled by a padlock.

⚠ WARNING

Children or untrained people can be seriously injured by this machine. This risk increases with unsupervised operation. To help prevent unsupervised operation, disable and lock the switch before leaving machine unattended! Place key in a well-hidden or secure location.

NOTICE

The padlock shaft diameter is important to the disabling function of the switch. With any padlock used to lock the switch, test the switch after installation to ensure that it is properly disabled.

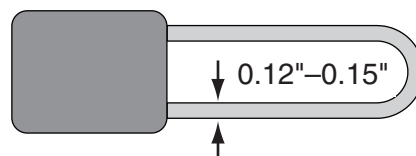

Figure 31. Minimum lock shaft requirements.



Workpiece Inspection

Some workpieces are not safe to cut or may require modification before they are safe to cut. **Before cutting, inspect all workpieces for the following:**

- **Material Type:** This machine is intended for cutting natural and man-made wood products, laminate covered wood products, and some plastics. Cutting drywall or cementitious backer board creates extremely fine dust and may reduce the life of the bearings. This machine is NOT designed to cut metal, glass, stone, tile, etc.; cutting these materials with a bandsaw may lead to injury.
- **Foreign Objects:** Nails, staples, dirt, rocks and other foreign objects are often embedded in wood. While cutting, these objects can become dislodged and hit the operator and bind or break the blade, which might then fly apart. Always visually inspect your workpiece for these items. If they can't be removed, DO NOT cut the workpiece.
- **Large/Loose Knots:** Loose knots can become dislodged during the cutting operation. Large knots can break blade teeth and cause machine damage. Choose workpieces that do not have large/loose knots or plan ahead to avoid cutting through them.
- **Wet or "Green" Stock:** Cutting wood with a moisture content over 20% causes unnecessary wear on the blades, increases the risk of kickback, and yields poor results.
- **Excessive Warping:** Workpieces with excessive cupping, bowing, or twisting are dangerous to cut because they are unstable and often unpredictable when being cut. DO NOT use workpieces with these characteristics!
- **Minor Warping:** Workpieces with slight cupping can be safely supported if the cupped side is facing the table or the fence. A workpiece supported on the bowed side may move unexpectedly resulting in severe injury.

Setting Upper Blade Guide Height

When cutting, the blade guides must always be positioned so they just clear (no more than $\frac{1}{4}$ ") the workpiece. The guide post, shown in **Figure 32**, allows the upper blade guide assembly to be quickly adjusted for height.

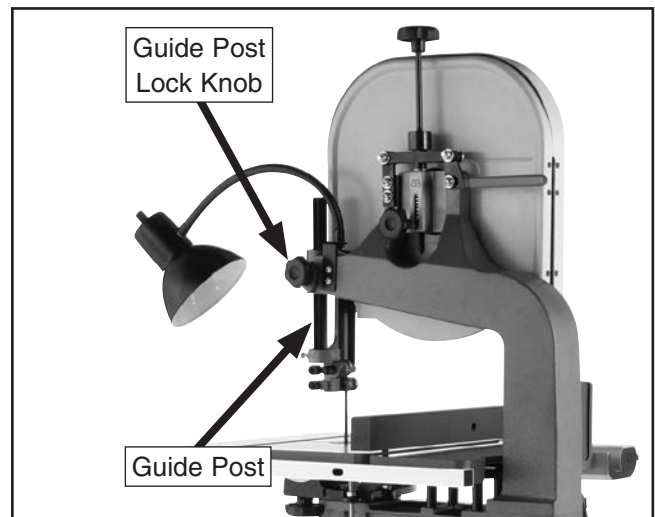

Figure 32. Guide post controls.

To adjust blade guide assembly on guide post:

1. DISCONNECT MACHINE FROM POWER!
2. Make sure that the blade tension, blade tracking, support bearing and blade guides are adjusted correctly.
3. Loosen the guide post lock knob shown in **Figure 32**.
4. Raise/lower the guide post so the bottom of the blade guide assembly is less than 1" from the top of the workpiece.
5. Lock the guide post with the lock knob.



Adjusting Table Tilt

The table can be tilted to make angled or beveled cuts. A simple tilt scale is provided on the trunnion for a quick gauge (see **Figure 33**). For more accurate results use a protractor.

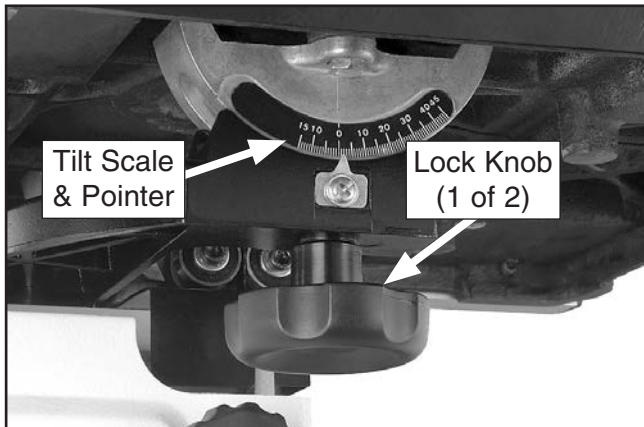

Figure 33. Table tilt controls.

Note: When tilting the table to the left, the positive stop bolt must be lowered. Be sure to re-adjust it when returning the table to be perpendicular with the blade.

To tilt table:

1. DISCONNECT BANDSAW FROM POWER!
2. Loosen both table lock knobs underneath table.
3. Tilt table to desired angle, then retighten lock knobs.

Blade Selection

Selecting the right blade requires a knowledge of the various blade characteristics to match the blade with the particular cutting operation.

Blade Terminology

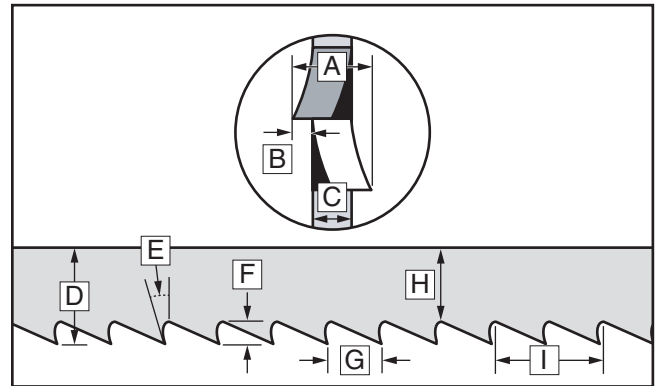

Figure 34. Bandsaw blade components.

- A. Kerf:** The amount of material removed by the blade during cutting.
- B. Tooth Set:** The amount each tooth is bent left or right along the blade.
- C. Gauge:** The thickness of the blade.
- D. Blade Width:** The widest point of the blade measured from the tip of the tooth to the back edge of the blade.
- E. Tooth Rake:** The angle of the tooth face from a line perpendicular to the length of the blade.
- F. Gullet Depth:** The distance from the tooth tip to the bottom of the curved area (gullet).
- G. Tooth Pitch:** The distance between tooth tips.
- H. Blade Back:** The distance between the bottom of the gullet and the back edge of the blade.
- I. TPI:** The number of teeth per inch measured from gullet to gullet.



Blade Dimensions

Length Range.....92¹/₂"–93¹/₂"
 Width Range.....¹/₈"–³/₄"

Blade Length

Measured by the blade circumference, blade lengths are specific to each bandsaw. They are determined by the wheel diameter and distance between the wheels. Blades will vary slightly even in the same length because of how they are welded. Refer to the **Accessories** section later in this manual for blade replacements from Grizzly.

Blade Width

Measured from the back of the blade to the tip of the blade tooth (the widest point), blade width is often the first consideration given to blade selection. Blade width dictates the largest and smallest curve that can be cut, as well as how accurately it can cut a straight line.

- **Curve Cutting:** Use the chart in **Figure 35** to determine the correct blade for curve cutting. Determine the smallest radius curve that will be cut on your workpiece and use the corresponding blade width.

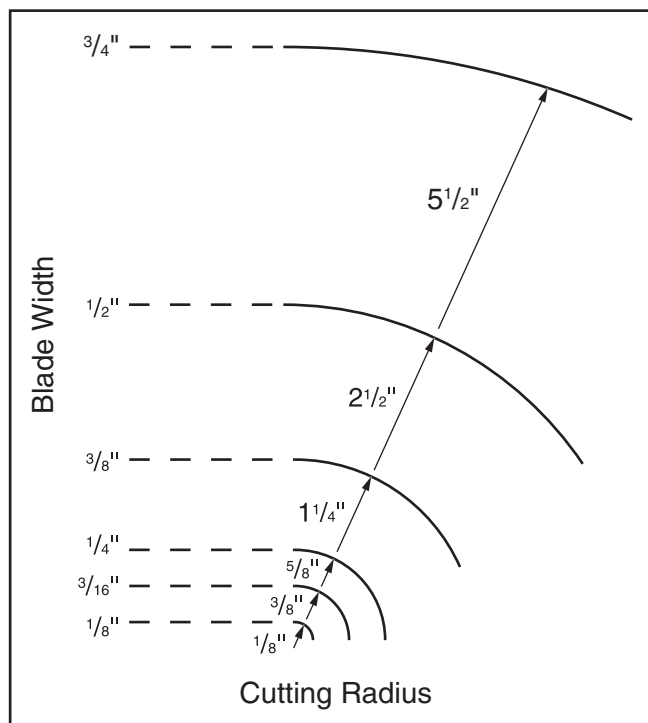

Figure 35. Recommended cutting radius per blade width.

- **Straight Cutting:** Use the largest width blade that you own. Large blades excel at cutting straight lines and are less prone to wander (known as blade lead—refer to **Page 48** for more information on blade lead).

Tooth Style

Figure 36 illustrates the three main blade tooth styles:

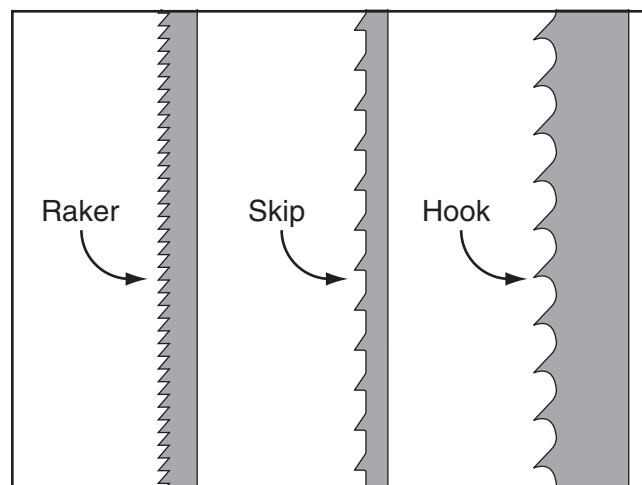

Figure 36. Main blade tooth styles.

- **Raker:** Considered to be the standard because the tooth size and shape are the same as the tooth gullet. The teeth on raker blades usually are very numerous, have no angle, and produce cuts by scraping the material. As a result, smooth cuts can be achieved without cutting fast or generating more heat than other tooth types.
- **Skip:** Similar to a raker blade that is missing every other tooth. Because of the design, skip toothed blades have a much larger gullet than raker blades, and therefore, cut faster and generate less heat. However, these blades also leave a rougher cut than raker blades.
- **Hook:** The teeth have a positive angle (downward) which makes them dig into the material, and the gullets are usually rounded for easier waste removal. These blades are excellent for the tough demands of resawing and ripping thick material.



Tooth Pitch

Measured as TPI (teeth per inch), tooth pitch determines the number of teeth. More teeth per inch (fine pitch) will cut slower, but smoother; while fewer teeth per inch (coarse pitch) will cut rougher, but faster. As a general rule, choose blades that will have at least three teeth in the material at all times. Use fine-pitched blades on harder woods and coarse-pitched blades on softer woods.

Tooth Set

Two common tooth sets for wood bandsaw blades are alternate and raker. Each different type of tooth set removes material in a different manner, leaving cuts with different characteristics (see **Figure 37**).

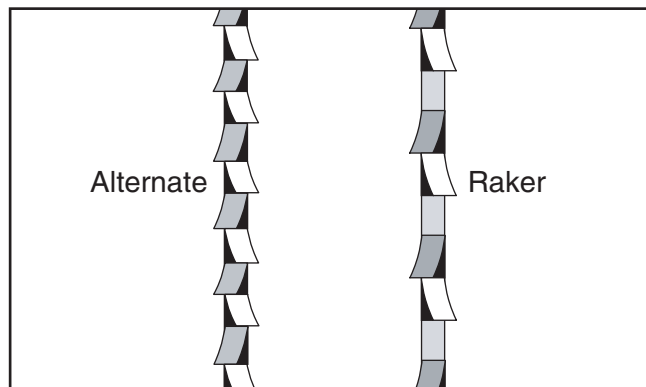

Figure 37. Common woodcutting bandsaw blade tooth sets.

- **Alternate:** An all-purpose arrangement where the teeth are bent evenly left and right of the blade.
- **Raker:** Three teeth in a recurring group—one bent left, one bent right, and then one that is not bent. The raker set is ideal for most contour cuts.

Blade Material

Bandsaw blades must meet two requirements: flexibility and hardness. The flexibility of a blade allows it to travel on the wheel as a band, while hardness allows the teeth to cut and hold an edge. Modern materials technology has allowed bandsaw blades to meet these requirements in various ways.

Carbon Steel: These blades are differentially heat treated to provide hard teeth that will hold an edge, and yet be flexible in the back.

Carbide Tooth: Extremely hard carbide is either welded onto or impregnated into the carbon steel blades, providing superior edge-holding characteristics (see **Figure 38**).

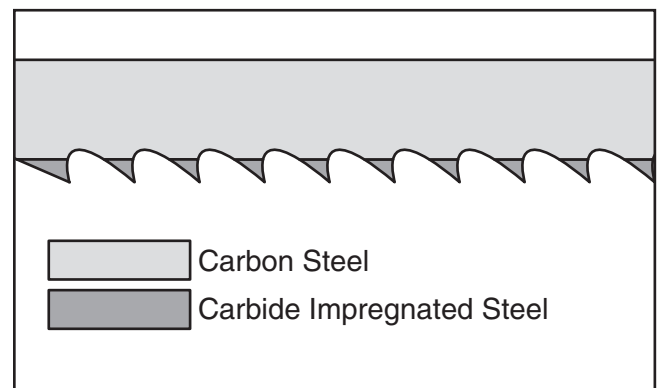

Figure 38. Carbide-tooth blade composition.

Bi-metal Blade: A strip of high-speed tool steel is precision welded to a flexible carbon blade, then teeth are ground into the blade to provide good edge-holding qualities for blades taking a lot of abuse (see **Figure 39**).

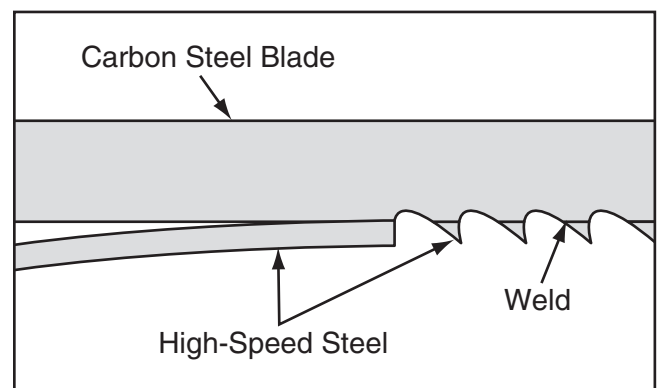

Figure 39. Bi-metal blade composition.



Blade Care & Break-In

Blade Care

A bandsaw blade is a thin piece of steel that is subjected to tremendous strain. You can obtain longer use from a bandsaw blade if you give it fair treatment and always use the appropriate feed rate for your operation.

Be sure to select blades with the proper width, set, type, and pitch for each application. Using the wrong blade will produce unnecessary heat and shorten the life of the blade.

A clean blade will perform much better than a dirty blade. Dirty or gummed up blades pass through the cutting material with much more resistance than clean blades. This extra resistance also causes unnecessary heat.

Blade Break-In

The tooth tips and edges of a new blade are extremely sharp, and cutting at too fast of a feed rate fractures the beveled edges of the teeth and causes premature blade wear.

To properly break in a new blade:

1. Choose correct speed for blade and material of operation.
2. Reduce feed pressure by half for first 50–100 in² of material cut.
3. To avoid twisting blade when cutting, adjust feed pressure when total width of blade is in cut.

Blade Breakage

Many conditions may cause a bandsaw blade to break. Blade breakage is unavoidable in some cases, since it is the natural result of the peculiar stresses that bandsaw blades are subjected to.

Blade breakage is also due to avoidable circumstances. Avoidable blade breakage is most often the result of poor care or judgement on the part of the operator when mounting or adjusting the blade or support guides.

The most common causes of blade breakage are:

- Faulty alignment or adjustment of the blade guides.
- Forcing or twisting a wide blade around a short radius.
- Feeding the workpiece too fast.
- Dull or damaged teeth.
- Over-tensioned blade.
- Upper blade guide assembly set too high above the workpiece. Adjust the top blade guide assembly so that there is approximately $\frac{1}{8}$ "– $\frac{1}{4}$ " between the bottom of the assembly and the workpiece.
- Using a blade with a lumpy or improperly finished braze or weld.
- Leaving the blade tensioned when not in use.
- Using the wrong pitch (TPI) for the workpiece thickness. The general rule of thumb is to have no less than two teeth in contact with the workpiece at all times during cutting.



Changing Blade

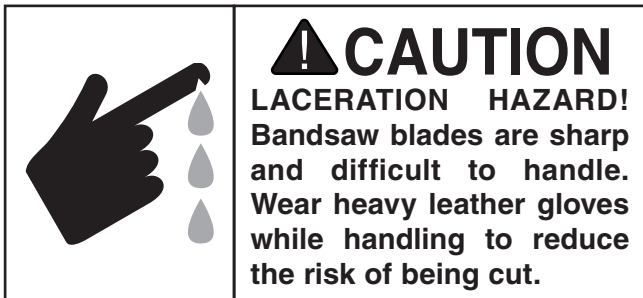
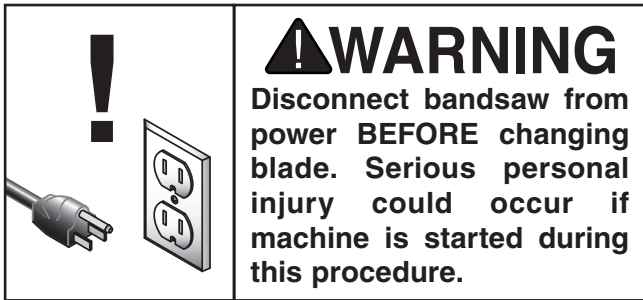

To remove blade:

1. DISCONNECT BANDSAW FROM POWER!
2. Release tension lever.
3. Remove table insert and table pin. Adjust upper and lower guide blocks away from blade.
4. Open upper and lower wheel covers and slide blade off both wheels.
5. Rotate blade 90° and slide it through slot in the table.

To replace blade:

1. Slide blade through table slot, ensuring teeth are pointing down toward table. *If teeth will not point downward in any orientation, the blade is inside-out. Put on heavy gloves, remove blade, and twist it rightside-out.*
2. Slip blade through guides, and mount it over upper and lower wheels.

3. Apply tension. If blade cannot be tensioned as described on **Page 23**, adjust the tensioner as described in **Steps 4-6**. If the tension is correct, go to **Step 7**.

Note: *The tensioner must be adjusted if you are using a different length of blade.*

4. Remove set screw in spacer indicated in **Figure 40**, and rotate spacer up 5-6 turns.

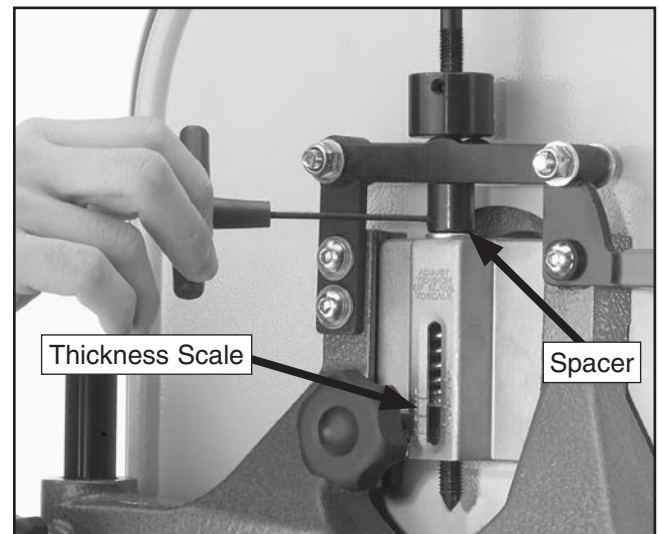

Figure 40. Tensioner adjustment.

5. Turn tension knob until proper blade tension has been reached according to blade thickness scale on sliding bracket. Fine tune as needed.
6. Thread spacer down until it lightly contacts top of sliding bracket. Move spacer back up shaft about 1-2 turns to leave a small space. Replace set screw in spacer and tighten (see **Figure 40**).
7. Check and adjust tracking.
8. Adjust upper/lower guide blocks and support bearings.
9. Close wheel covers.
10. Replace table insert and table pin, being sure not to use excessive force when inserting table pin.



Scale Calibration

You may need to recalibrate the fence scale after changing or adjusting the blade, or if the scale is not producing accurate cuts. Recalibrate the fence scale by adjusting the hairline indicator on the fence and testing your adjustment by cutting a piece of scrap wood.

To calibrate scale:

1. Set fence anywhere along scale and locate a piece of scrap wood with at least one straightedge. *Joint edge with a jointer if needed to make the edge straight.*
2. Hold straight edge of workpiece firmly against fence, and feed workpiece through saw blade with a push stick.
3. Measure width of cut workpiece. The width of workpiece should match the reading on the fence scale.
4. If reading on scale is not the same as the width of cut workpiece, loosen screws on magnifying window (see **Figure 41**) and adjust it to match width of cut workpiece.
5. Tighten screws; scale is now correctly calibrated.



Figure 41. Scale recalibration screws.

Ripping

"Ripping" means cutting with the grain of the wood stock. For plywood and other processed wood, ripping simply means cutting down the length of the workpiece.

To make a rip cut:

1. Adjust fence to match width of cut on your workpiece, then lock fence in place.
2. Adjust blade guide assembly to less than 1" away from workpiece.
3. After all safety precautions have been met, turn bandsaw **ON**. Slowly feed workpiece into blade and continue with cut until blade is completely through workpiece. **Figure 42** shows a typical ripping operation.

Note: *If you cut narrow pieces, use a push stick to protect your fingers.*



Figure 42. Typical ripping operation.

!WARNING

NEVER place fingers or hands in the line of cut. If you slip, your hands or fingers may go into the blade. **ALWAYS** use a push stick when ripping narrow pieces. Failure to follow these warnings may result in serious personal injury!



Crosscutting

"Crosscutting" means cutting across the grain of wood. For plywood and other processed wood, crosscutting simply means cutting across the width of the workpiece.

To make a 90° crosscut:

1. Mark workpiece on edge where you want to begin the cut.
2. Adjust blade guide assembly to less than 1" away from workpiece and make sure miter gauge is set to 90°.
3. Move fence out of the way. Place the workpiece evenly against the miter gauge.
4. Hold the workpiece against the miter gauge and align the mark with the blade.
5. After all safety precautions have been met, turn the bandsaw **ON**. Slowly feed the workpiece into the blade and continue the cut until the blade is all the way through the workpiece. **Figure 43** shows a typical crosscutting operation.



Figure 43. Typical crosscutting operation.

Resawing

"Resawing" (see **Figure 44**) means cutting the thickness of a board into two or more thinner boards. The maximum board width that can be resawn is limited by the maximum cutting height of the bandsaw.

One of the most important considerations for resawing is blade selection—a wide blade cuts straighter and is less prone to blade lead (see **Page 48** for more info on blade lead).

For most applications, use a blade with a hook or a skip tooth style. Choose blades with fewer teeth-per-inch (from 3 to 6), because they offer larger gullet capacities for clearing sawdust, reducing heat buildup and reducing strain on the motor.



Figure 44. Typical resawing operation.

To resaw a workpiece:

1. Verify that the bandsaw is setup properly and that the table is perpendicular to the blade.
2. Use the widest blade your bandsaw will accept. **Note:** *The blade must also be sharp and clean.*
3. Install the resaw fence, adjust it to the desired width of cut, and lock it in place.



!WARNING

When resawing thin pieces, a wandering blade (blade lead) can tear through the side of the workpiece, exposing your hands to the blade teeth. Always use push blocks when resawing and keep your hands clear of the blade.

4. Support the ends of the board if necessary.
5. Turn the bandsaw **ON**.
6. Using push paddles and a push stick, maintain workpiece pressure against the fence and table, and slowly feed the workpiece into the moving blade until the blade is completely through the workpiece (see **Figure 44**).

Cutting Curves

When cutting curves, simultaneously feed and turn the stock carefully so the blade follows the layout line without twisting. If a curve is so abrupt that it is necessary to repeatedly back up and cut a new kerf, use a narrower blade, a blade with more TPI (teeth per inch), or more relief cuts.

Relief cuts are cuts made through the waste portion of the workpiece and are stopped at the layout line. Relief cuts reduce the chance that the blade will be pinched or twisted by removing waste wood from the workpiece and alleviating any pressure on the back of the blade.

NOTICE

The list below shows the minimum radii for different blade widths.

Width	Radius
1/8"	1/8"
3/16"	3/8"
1/4"	5/8"
3/8"	1 1/4"
1/2"	2 1/2"
5/8"	3 3/4"
3/4"	5 1/2"

Stacked Cuts

One of the benefits of a bandsaw is its ability to cut multiple copies of a particular shape by stacking workpieces together and cutting them as one. Before making stacked cuts, ensure that both the table and the blade are properly adjusted to 90°; otherwise, any error will be compounded.

To complete a stacked cut:

1. Align your pieces from top-to-bottom to ensure that each piece has adequate scrap to provide a clean, unhampered cut.
2. Secure all the pieces together in a manner that will not interfere with the cutting. Hot glue on the edges works well, as do brad nails through the waste portion. (Be careful not to cut into the brads or you may break the blade!)
3. On the face of the top piece, mark the shape you intend to cut.
4. Make relief cuts perpendicular to the outline of your intended shape in areas where changes in blade direction could cause the blade to bind.
5. Cut the stack of pieces as though you were cutting a single piece. Follow your layout line with the blade kerf on the waste side of your line as shown in **Figure 45**.

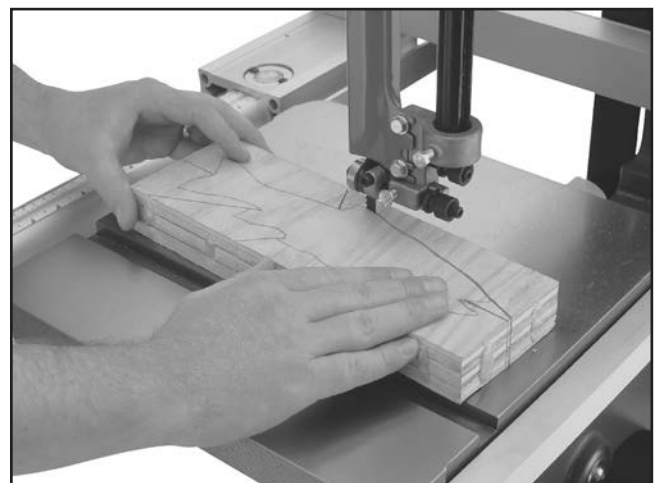

Figure 45. Typical stacked cut.



SECTION 5: ACCESSORIES

!WARNING

Installing unapproved accessories may cause machine to malfunction, resulting in serious personal injury or machine damage. To reduce this risk, only install accessories recommended for this machine by Grizzly.

NOTICE

Refer to our website or latest catalog for additional recommended accessories.

- G5562—SLIPIT® 1 Qt. Gel
- G5563—SLIPIT® 12 oz. Spray
- G2870—Boeshield® T-9 4 oz. Spray
- G2871—Boeshield® T-9 12 oz. Spray
- H3788—G96® Gun Treatment 12 oz. Spray
- H3789—G96® Gun Treatment 4.5 oz. Spray



Figure 46. Recommended lubricants for protecting unpainted cast iron/steel part on machinery.

H3051—Riser Block Kit for G0555 & G0555X
Increase your G0555 or G0555X 14" Bandsaw's cutting capacity to 12" high with this bolt-on 6" extension block kit. Includes all necessary hardware plus extended blade guard and 3/8" x 105" x 6 TPI blade.

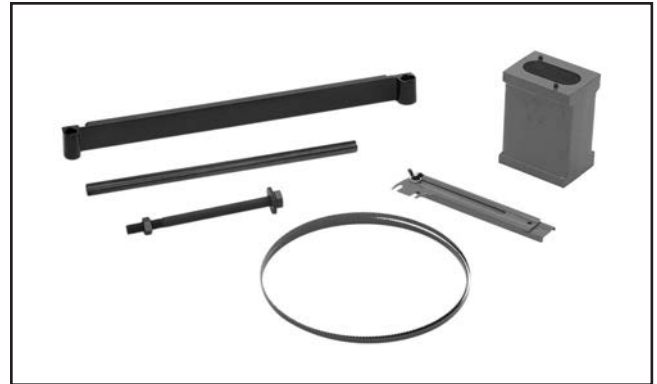

Figure 47. H3051 Riser Block Kit.

T28000—"Bear Crawl" Mobile Base

We took years of input and months of testing and design to come out with the Grizzly "Bear Crawl" Mobile Base. Its 1200 lb. capacity, steel and rubber heavy-duty ball bearing wheels, and toe flip-stops are only a few of the features that will make this mobile base a staple under your machines for years to come. Adjusts from 19" x 21" to 29½" x 29½"!

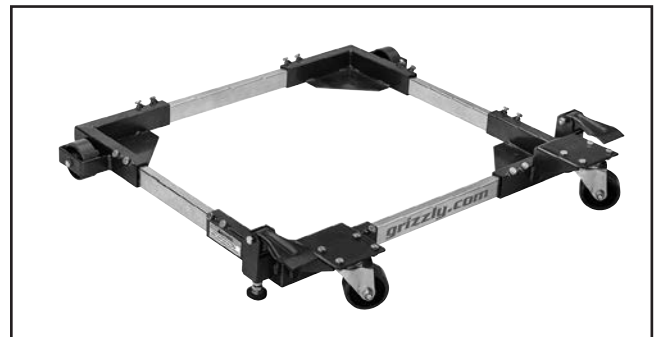

Figure 48. T28000 Bear Crawl Mobile Base.

order online at www.grizzly.com or call 1-800-523-4777



T1194—Resaw Fence w/Drift Bar

Anyone who's ever tried to rip or resaw on a bandsaw without adjusting for blade drift knows the natural line of cut is not always parallel to the fence. Forcing the wood against the fence will put strain on the blade and cause a wandering cut line. The easiest way to compensate for blade drift is to scribe a cut line on the edge or face of your workpiece and use a drift bar mounted to your fence. The drift bar allows you to adjust the angle of cut to the scribed line, ensuring a uniform thickness without putting undue strain on the blade. This includes the 19⁷/₈" x 5¹⁵/₁₆" resaw fence and drift bar so you have everything you need to start cutting down on drift!

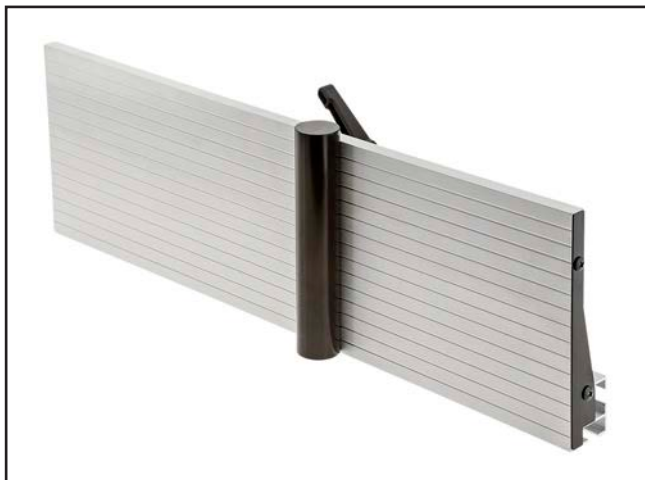

Figure 49. T1194 Resaw Fence with Drift Bar.

T23070—Replacement Tires

These are replacement tires for the G0555, G0555X, G0555P, and G0580 bandsaws.

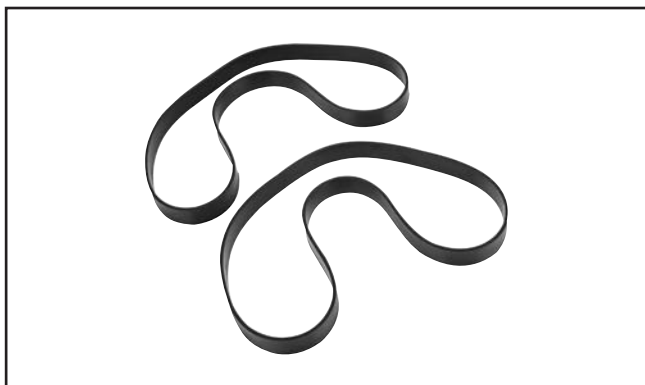

Figure 50. T23070 Replacement Tires.

T26403—The Missing Shop Manual: Bandsaw

Dedicated to providing integral information about woodworking tools and techniques that other manuals overlook, the books in this series contain safety facts, explanations about basic project set up, and tips for maximizing tool performance. In Bandsaw, you will find out how to best utilize this essential workshop tool, and how to get the most for your money by getting the most from your equipment. Filled with clear diagrams and instructions, this pocket sized durable manual is ideal for quick reference in the workshop. 112 pages, soft cover.

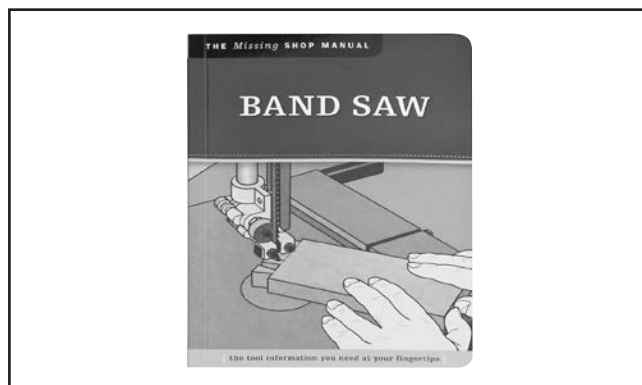

Figure 51. The Missing Shop Manual: Bandsaw.

H6572—Grease-Resistant Mat 3' x 3' x 3/4"

These Black Grease Resistant Mats are engineered for proper back and leg support, using super-tough virgin rubber material. The non-slip surface features a modular interlock design, which enables the user to create a custom floor. Mats measure 36" x 36" x 3/4".

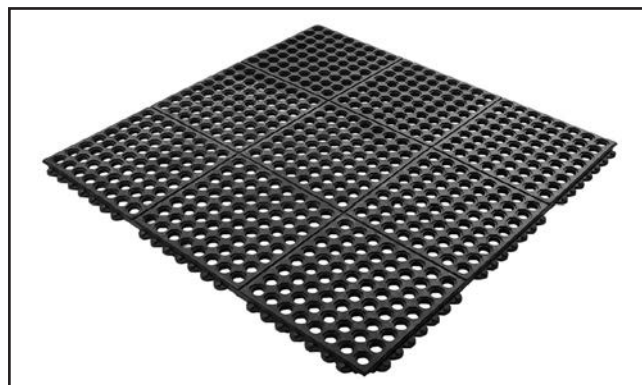
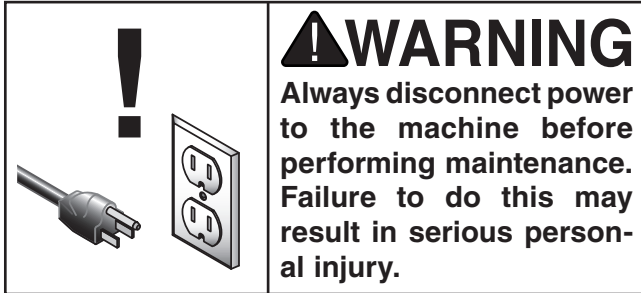

Figure 52. H6572 Grease-Resistant Mat 3' x 3' x 3/4".

order online at www.grizzly.com or call 1-800-523-4777



SECTION 6: MAINTENANCE



Schedule

For optimum performance from this machine, this maintenance schedule must be strictly followed.

Ongoing

To maintain a low risk of injury and proper machine operation, if you ever observe any of the items below, shut down the machine immediately and fix the problem before continuing operations:

- Loose mounting bolts.
- Worn or damaged saw blade.
- Worn or damaged wires.
- Check/clean wheel brush.
- Clean/protect table surface.
- Check lubrication points.
- Any other unsafe condition.

Monthly

- Check for V-belt tension, damage, or wear.
- Remove blade and thoroughly clean all built-up sawdust from the rubber tires on the wheels.
- Clean/vacuum dust buildup from inside cabinet and off motor.

Cleaning

Vacuum excess wood chips and sawdust, and wipe off the remaining dust with a dry cloth. If resin has built up, use a resin dissolving cleaner to remove it. Once a month, remove the blade and thoroughly clean all built-up sawdust from the rubber tires on the wheels.

Lubricating

Protect the unpainted cast iron surfaces on the table by wiping the table clean after every use—this ensures moisture from wood dust does not remain on bare metal surfaces. Keep tables rust-free with regular applications of products like G96® Gun Treatment, SLIPIT®, or Boeshield® T-9 on **Page 40**.

If the table becomes difficult to tilt, remove it and lubricate the trunnions and the slides in the trunnion base.

Redressing Rubber Tires

As the bandsaw ages, the rubber tires may need to be redressed if they harden or glaze over. Redressing the rubber tires improves blade tracking and reduces vibration/blade lead.

To redress rubber tires:

1. DISCONNECT MACHINE FROM POWER!
2. Put on heavy leather gloves.
3. Remove blade.
4. Clean any built-up sawdust from rubber tires.
5. Hold 100-grit sandpaper against rubber tire and rotate wheel by hand. Only redress rubber enough to expose a fresh rubber surface.

Note: *If the rubber tires become too worn, then blade tracking will become extremely difficult. At that point, redressing will no longer be effective and the rubber tires must be replaced.*



SECTION 7: SERVICE

Review the troubleshooting procedures in this section if a problem develops with your machine. If you need replacement parts or additional help with a procedure, call our Technical Support. **Note:** *Please gather the serial number and manufacture date of your machine before calling.*

Troubleshooting

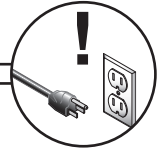

Motor & Electrical

Symptom	Possible Cause	Possible Solution
Machine does not start or a breaker trips immediately upon startup.	<ol style="list-style-type: none"> 1. Incorrect power supply voltage. 2. Power supply circuit breaker tripped or fuse blown. 3. Motor wires connected incorrectly. 4. Wiring open/has high resistance. 5. ON/OFF switch at fault. 6. Start capacitor at fault. 7. Centrifugal switch at fault. 8. Motor at fault. 	<ol style="list-style-type: none"> 1. Ensure correct power supply voltage. 2. Ensure circuit is sized correctly and free of shorts. Reset circuit breaker or replace fuse. 3. Correct motor wiring connections (Page 53). 4. Check/fix broken, disconnected, or corroded wires. 5. Replace switch. 6. Test/replace. 7. Adjust/replace centrifugal switch if available. 8. Test/repair/replace.
Machine stalls or is underpowered.	<ol style="list-style-type: none"> 1. Dull or incorrect blade for task. 2. Workpiece material not suitable for machine, or feed rate/pressure too heavy. 3. Belt slipping; oil/grease on belt. 4. Blade slipping on wheels. 5. Motor wired incorrectly. 6. Run capacitor at fault. 7. Pulley/sprocket slipping on shaft. 8. Centrifugal switch at fault. 9. Motor bearings at fault. 	<ol style="list-style-type: none"> 1. Sharpen/replace blade (Page 36). Use correct blade. 2. Only cut wood—ensure moisture is below 20%, reduce feed rate or depth of cut. 3. Clean/tension/replace belt (Page 36). 4. Adjust blade tracking and tension (Page 20). Ensure proper blade size. 5. Wire motor correctly (Page 53). 6. Test/repair/replace. 7. Tighten/replace loose pulley/shaft. 8. Adjust/replace centrifugal switch if available. 9. Test/repair/replace.
Machine has vibration or noisy operation.	<ol style="list-style-type: none"> 1. Motor or component loose. 2. Large blade weld or blade at fault. 3. V-belt worn or loose. 4. Motor fan rubbing on fan cover. 5. Motor mount loose/broken. 6. Pulley loose. 7. Machine incorrectly mounted. 8. Centrifugal switch at fault. 9. Motor bearings at fault. 	<ol style="list-style-type: none"> 1. Inspect/replace damaged bolts/nuts and retighten use thread-locking fluid if necessary. 2. Replace warped/bent/broken blade; replace/resharpen dull blade (Page 36). 3. Inspect/replace belt (Page 46). 4. Fix/replace fan cover; replace loose/damaged fan. 5. Tighten/replace. 6. Re-align/replace shaft, pulley set screw, and key. 7. Tighten mounting bolts; relocate/shim machine. 8. Replace. 9. Test by rotating shaft; rotational grinding/loose shaft requires bearing replacement.



Operating Machine

Symptom	Possible Cause	Possible Solution
Blade or teeth break/crack.	<ol style="list-style-type: none"> 1. Blade tension is too tight. 2. Blade is incorrect for application. 3. Excessive feed rate/pressure. 4. Cutting corners too sharply. 5. Blade is dull or worn/weld at fault. 6. Blade is tracking incorrectly. 7. Blade guides/support bearings not adjusted properly, allowing blade teeth to hit guides while cutting. 	<ol style="list-style-type: none"> 1. Reduce blade tension (Page 23). 2. Use correct blade for application (Page 32). 3. Reduce feed rate/pressure. 4. Use a wider arc on outside cuts, or use relief cuts to make tight inside cuts. 5. Replace blade (Page 36). 6. Properly adjust blade tracking (Page 20). 7. Adjust blade guides/support bearings properly, so teeth cannot contact guides during operation (Pages 24–25).
Blade slows, smokes, shows overheating or wears on one side.	<ol style="list-style-type: none"> 1. Blade contacting table insert. 2. Blade guides are misadjusted or worn. 3. Blade installed backwards. 4. Too much side pressure when feeding workpiece. 5. Wheels are out of alignment. 6. Fence not parallel with blade. 7. Dull, bell-mouthed, or incorrect blade. 8. V-belt loose, worn or slipping. 	<ol style="list-style-type: none"> 1. Adjust blade guides to eliminate any side pressure (Pages 24–25). Properly align table (Page 28). 2. Adjust guides properly. Replace blade guides if worn. 3. Check blade rotation. Reverse blade if necessary (Page 36). 4. Feed workpiece straight into blade. 5. Adjust wheels to be coplanar (Page 50). 6. Adjust fence parallelism with blade (Page 28). 7. Replace blade (Page 36). 8. Tighten V-belt. Replace if worn or oily (Page 46).
Finished workpieces are rough or show scoring.	<ol style="list-style-type: none"> 1. Blade is overloaded and twists. TPI is too fine. Blade is too narrow for cutting task. 2. Blade TPI is too coarse or tooth style incorrect. 3. Blade is loose and fluttering. 4. Blade tracking is incorrect. 5. Blade has missing/bent teeth, or faulty weld. 	<ol style="list-style-type: none"> 1. Decrease feed rate; ensure proper TPI (Page 32). 2. Use correct blade for material and speed of cut (Page 32). 3. Properly adjust blade tension (Page 23). 4. Adjust blade tracking (Page 20). 5. Replace blade (Page 36).
Table is hard to tilt.	<ol style="list-style-type: none"> 1. Table tilt lock knobs engaged. 2. Sawdust or pitch trapped between trunnion and base. 3. Metal burrs on trunnion. 	<ol style="list-style-type: none"> 1. Disengage table tilt lock knobs. 2. Remove table and clean trunnion sliding surfaces free of sawdust or pitch. 3. Remove burrs.
Table does not accurately tilt to 45 or 0 degrees.	<ol style="list-style-type: none"> 1. Table tilt scale pointer not calibrated. 2. Positive stop not set correctly. 	<ol style="list-style-type: none"> 1. Calibrate table tilt scale pointer (Page 27). 2. Adjust positive stop (Page 26).
Miter bar binds in miter slot.	<ol style="list-style-type: none"> 1. Miter slot dirty or gummed up. 2. Miter bar is bent. 	<ol style="list-style-type: none"> 1. Carefully clean miter slot. 2. Replace.



Operating Machine (Cont.)

Symptom	Possible Cause	Possible Solution
Blade tracks incorrectly or comes off wheels.	<ol style="list-style-type: none"> 1. Tracking not adjusted properly. 2. Wheels are not coplanar. 3. Blade tension too loose. 4. Blade guides/support bearings are too tight. 5. Feeding workpiece too fast. 6. Incorrect blade for operation. 7. Blade is bell-mouthed, worn, or dull. 8. Rubber tire or wheel is damaged or worn. 	<ol style="list-style-type: none"> 1. Adjust tracking (Page 20). 2. Adjust wheels to be coplanar (Page 50). 3. Increase blade tension (Page 23). 4. Properly adjust blade guides/support bearings (Pages 24–25). 5. Feed workpiece slower. 6. Install correct blade (Page 32). 7. Install new blade and remove tension from blade when not in use. 8. Replace rubber tires or wheel and remove tension from blade when no in use.
Cut is crooked or blade wanders (blade lead).	<ol style="list-style-type: none"> 1. Excessive feed rate/pressure. 2. Blade tension too loose. 3. Blade is too narrow or tooth type/TPI is incorrect for the cut. 4. Inadequate blade support. 5. Blade dull or has damaged tooth set from improper guides/support bearing adjustment. 6. Blade tracking is incorrect. 7. Table is loose. 8. Fence or miter slot out of alignment with blade. 9. Tooth set is uneven or teeth are sharper on one side than the other. 	<ol style="list-style-type: none"> 1. Reduce feed rate/pressure. 2. Increase blade tension (Page 23). 3. Use wider blade. Ensure tooth type & TPI is correct (Page 32). 4. Position upper blade guides to just clear workpiece. Properly adjust blade guides/support bearings (Pages 24–25). 5. Replace blade (Page 36). 6. Adjust blade tracking (Page 20). 7. Tighten table trunnion mounting bolts or tilt lock lever. 8. Align table miter slot and fence with blade (Page 28). 9. Properly adjust blade guides/support bearings (Pages 24–25) and replace blade (Page 36).
Blade prematurely gets dull.	<ol style="list-style-type: none"> 1. Excessive feed rate/pressure. 2. Wrong blade tooth type or TPI for cutting operation/material. 3. Blade is twisted. 4. Blade is slipping on wheel. 5. Blade guides hitting teeth and ruining tooth set. 	<ol style="list-style-type: none"> 1. Reduce feed rate/pressure. 2. Use blade with correct tooth type and TPI. (Page 32). 3. Replace blade (Page 36). 4. Adjust blade tension (Page 23). 5. Properly adjust guide bearings (Page 25).
Gullets loaded with chips.	<ol style="list-style-type: none"> 1. Wrong cutting speed. 2. Blade TPI is too fine. 	<ol style="list-style-type: none"> 1. Adjust cutting speed. 2. Install correct blade (Page 32).
Backside of blade deformation/cracking.	<ol style="list-style-type: none"> 1. Excessive feed rate/pressure. 2. Blade tension too high. 3. Blade support bearing improperly adjusted. 	<ol style="list-style-type: none"> 1. Reduce feed rate/pressure. 2. Adjust blade tension (Page 23). 3. Properly adjust blade support bearing (Page 24).
Sawdust buildup inside cabinet.	<ol style="list-style-type: none"> 1. Blade brush under table is worn or mis-adjusted. 2. Clogged dust port. 3. Low CFM (airflow) from dust collection system. 	<ol style="list-style-type: none"> 1. Properly adjust brush; replace if necessary. 2. Clean dust port. 3. Inspect ducting for leaks/clogs and repair as necessary; move dust collector closer to machine; install a stronger dust collector.



Tensioning V-Belt

To ensure optimum power transmission from the motor to the blade, V-belt must be in good condition and operate under proper tension.

V-belt tension should be checked at least every month—more often if the bandsaw is used daily. If belt shows signs of cracks, fraying, and excessive wear, replace it. (refer to **Replacing V-Belt** on **Page 47** for instructions).

Checking V-Belt Tension

1. DISCONNECT MACHINE FROM POWER!
2. Open lower wheel cover.
3. Check V-Belt deflection. V-belt is properly tensioned if there is approximately $\frac{1}{4}$ " deflection. Deflection is checked by pushing V-belt with moderate pressure, as shown in **Figure 53**, and noting how much it moves.

—If V-belt is not properly tensioned, perform following **Tensioning V-Belt** procedure.

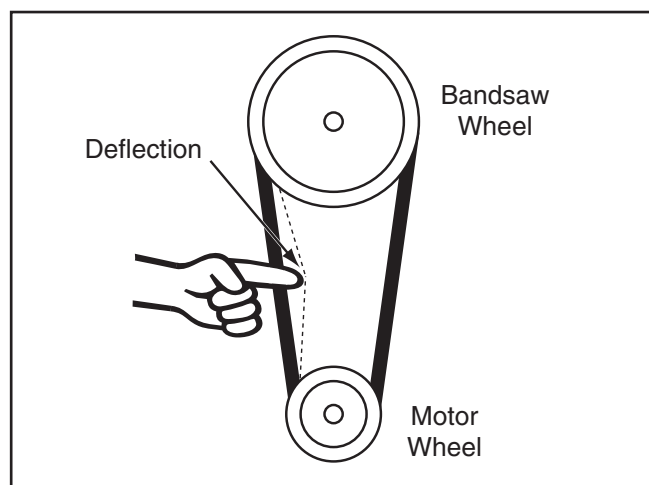

Figure 53. Belt deflection.

Tensioning V-Belt

Items Needed	Qty
Hex Wrench 6mm.....	1

To properly tension V-belt:

1. DISCONNECT MACHINE FROM POWER!
2. Open lower wheel cover, and loosen motor mount cap screws shown in **Figure 54**.

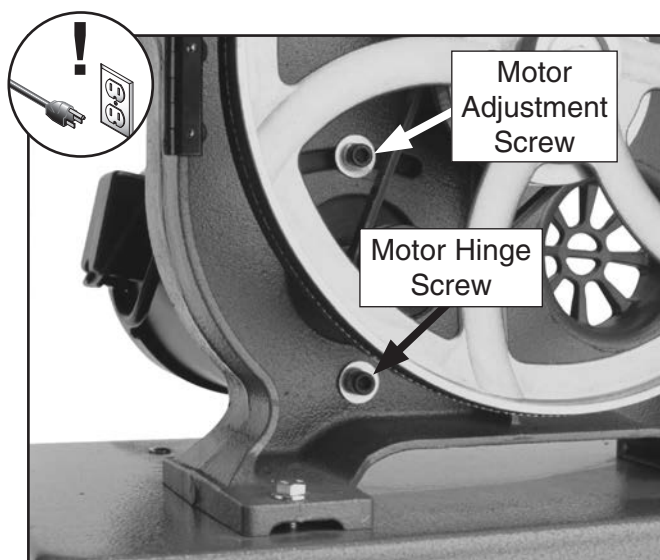

Figure 54. Motor mount screws.

3. Push motor to the left (as viewed from front of machine) until there is approximately $\frac{1}{4}$ " deflection in V-belt.
4. Re-tighten both cap screws and close wheel cover.



Replacing V-Belt

To ensure optimum power transmission from motor to blade, V-belt must be in good condition and be properly tensioned.

Replace V-belt if it shows signs of cracking, fraying, and excessive wear.

Items Needed	Qty
Hex Wrench 6mm.....	1
Open-End Wrench or Socket 13mm	1
Replacement V-Belt	1

To replace the belt:

1. DISCONNECT BANDSAW FROM POWER!
2. Open both wheel covers.
3. Remove bandsaw blade.
4. Loosen motor mount bolt shown in **Figure 55**.

5. Move body of motor so motor adjustment bolt slides to the right-hand side of adjustment slot.
6. Pull belt off of motor pulley.
7. Unthread wheel mount bolt shown in **Figure 55**, and slide lower wheel off of bearing shaft.
8. Slip old belt off of wheel pulley and install the new belt in its place.
9. Re-install lower wheel onto bearing shaft, and replace/tighten wheel mount bolt.
10. Position belt over motor pulley.
11. Move body of motor so motor adjustment bolt slides to the left-hand side of adjustment slot.
12. Hold motor in position with one hand and tighten motor adjustment bolt with the other hand.
13. Check belt tension and adjust if necessary (see **Tensioning Belt** on **Page 46**).
14. When belt tension is correct, tighten motor hinge bolt and close lower wheel cover.

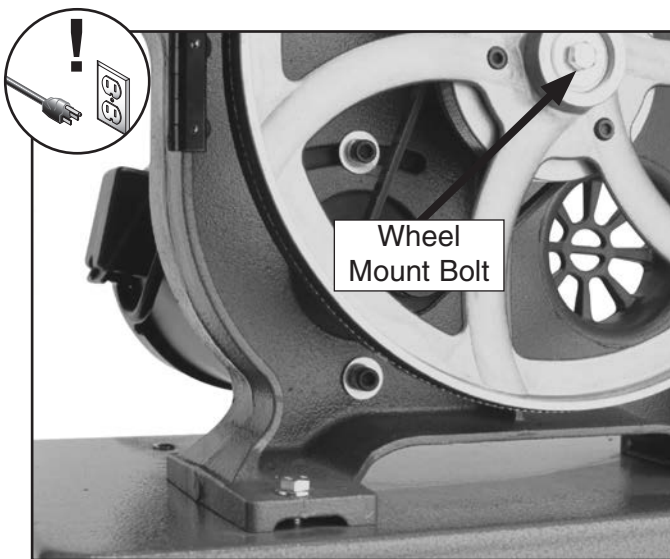

Figure 55. Wheel mount bolt.



Shimming Table

To ensure accuracy when cutting stacked workpieces, the table should be 90° to the back of the blade as shown in **Figure 56**. If the table is not perpendicular to the back of the blade, the table needs to be shimmed.

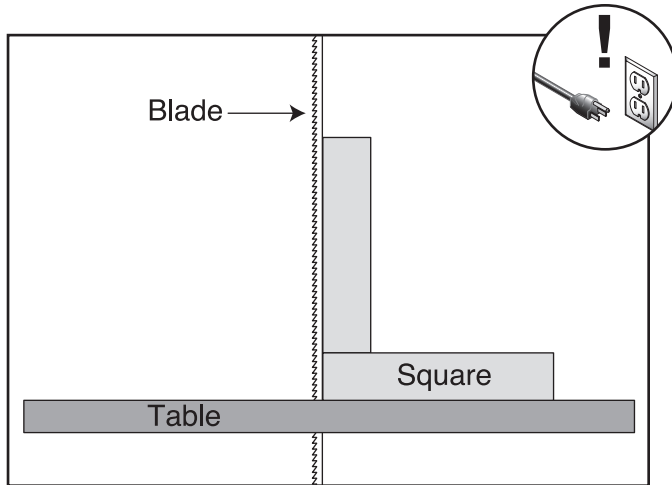

Figure 56. Squaring table to blade back.

To shim the table:

1. Make sure that the blade is tracking properly and that it is correctly tensioned.
2. DISCONNECT BANDSAW FROM POWER!
3. Loosen the trunnion bolts that secure the trunnions to the table.
4. Place shim stock between the table and the two trunnions to shim the table in the desired direction.

Note: Another way to shim the table is to add washers between the table and the trunnion. Electrical washers are a good choice for this procedure because they are very thin and will allow for fine adjustment.

5. Follow the **Aligning Miter Slot** instructions on **Page 28** to complete this procedure.

Correcting Blade Lead

"Blade Lead" means that the blade does not cut straight when using the fence or miter gauge (see **Figure 57**). This is a common condition with all bandsaws. Worn or damaged blades may cause lead and replacing them will fix the problem. Still, if your bandsaw is setup correctly and lead occurs, compensate for it by skewing the fence.

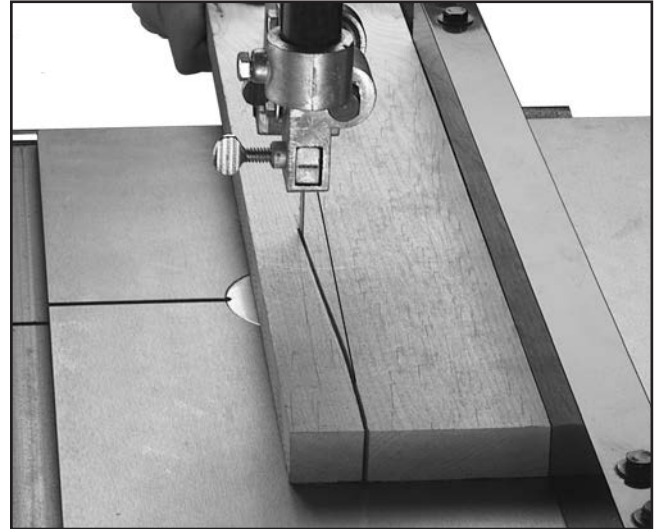

Figure 57. Blade leading away from line of cut.

To correct blade lead, do the following steps and make a test cut before skewing the fence:

1. Ensure that you have proper blade tension (refer to **Page 23**).
2. Ensure that the blade guides are adjusted correctly (refer to **Pages 24 & 25**).
3. Ensure that the miter slot or fence is parallel to the blade (refer to **Page 28**).

To skew your fence:

1. Cut a piece of scrap wood approximately $\frac{3}{4}$ " thick x 3" wide x 17" long. On a wide face of the board, draw a straight line parallel to the long edge.
2. Slide the fence out of the way and cut free-hand along the line. Stop at the halfway point. Turn the bandsaw **OFF** and wait for the blade to stop.



3. Clamp the board to the bandsaw table without moving it. Now slide the fence over to the board so it barely touches one end of the board.
4. Loosen the four cap screws on top of the fence.
5. Skew the fence as needed until it is parallel to the edge of the scrap piece. You may need to re-adjust the fence locking mechanisms to gain maximum adjustment.
6. While maintaining the skew, tighten the cap screws.

To compensate for lead when making straight crosscuts with the miter gauge, you will need to shift the table:

1. Set the miter gauge to 90°.
2. On a scrap piece of wood, mark a line that is perpendicular to the front edge. Starting where the line begins, cut the board by pushing it through the blade with the miter gauge. *The miter gauge should be checked for square before beginning this procedure.*
3. Loosen the table mounting bolts, and shift the table to compensate for the blade lead.
4. Repeat **Steps 1 & 2** until the blade cuts straight when wood is pushed through with the miter gauge.

NOTICE

If the table is shifted, the fence will be affected since it is attached.

NOTICE

Lead adjustments will change when new blades are mounted on the saw.

Calibrating Fence Scale

You may need to recalibrate the fence scale after changing or adjusting the blade, or if the scale is not producing accurate cuts. Recalibrate the fence scale by adjusting the hairline indicator on the fence and testing your adjustment by cutting a piece of scrap wood.

Items Needed	Qty
Phillips Screwdriver #1	1

To calibrate scale:

1. Set fence anywhere along scale and locate a piece of scrap wood with at least one straight edge.

Note: *Joint the edge with a jointer if needed to make the edge straight.*
2. Hold straight edge of workpiece firmly against fence, and feed workpiece through saw blade with a push stick.
3. Measure the width of cut workpiece. The width of workpiece should match reading on fence scale.
4. If reading on scale is not the same as width of cut workpiece, loosen two screws on magnifying window (see **Figure 58**) and adjust it to match width of the cut workpiece.

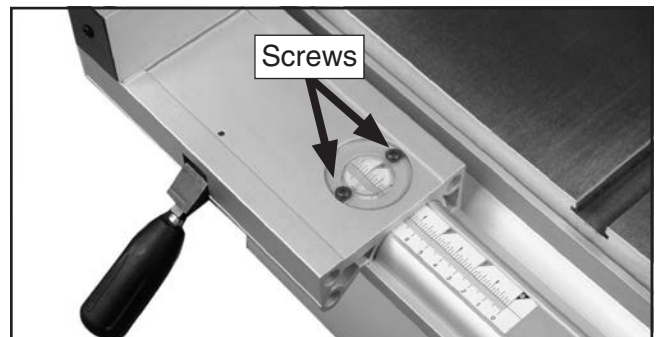

Figure 58. Example of fence scale window and screws.

5. Re-tighten screws—scale is now correctly calibrated.



Wheel Alignment

Wheel alignment is important for optimal performance from your bandsaw. Wheels are properly aligned when they are parallel with each other and in the same plane or “coplanar” (see the illustration in the figure to the right).

When wheels are coplanar, the bandsaw is more likely to cut straight without wandering; and vibration, heat, and blade wear are considerably decreased because the blade is automatically balanced on the wheel.

Bringing the wheel into alignment may require a combination of shimming a wheel and center/lateral tracking the blade.

Items Needed	Qty
Straightedge 4 ft.....	1
Fine Ruler.....	1
Open-Ended Wrench or Socket 13mm	1
Open-Ended Wrench or Socket 19mm	1

Checking Wheel Alignment

1. DISCONNECT MACHINE FROM POWER!
2. Remove table.
3. With blade on and properly tensioned, hold a straightedge close to center of both wheels. Make sure straightedge fully extends across rims of both wheels, as shown in **Figure 59**.

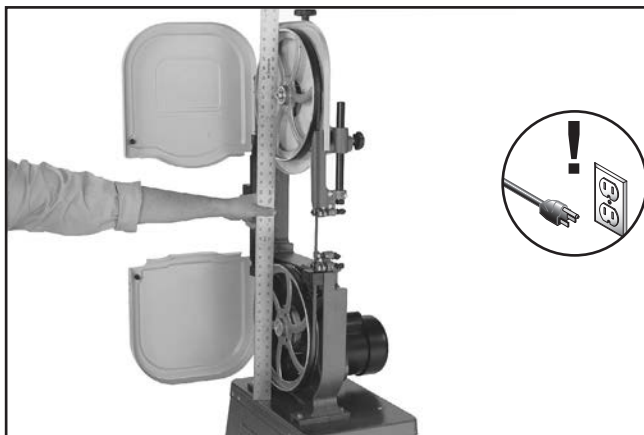

Figure 59. Checking wheel alignment with a straightedge.

4. Referring to **Figure 60**, check wheel alignment.

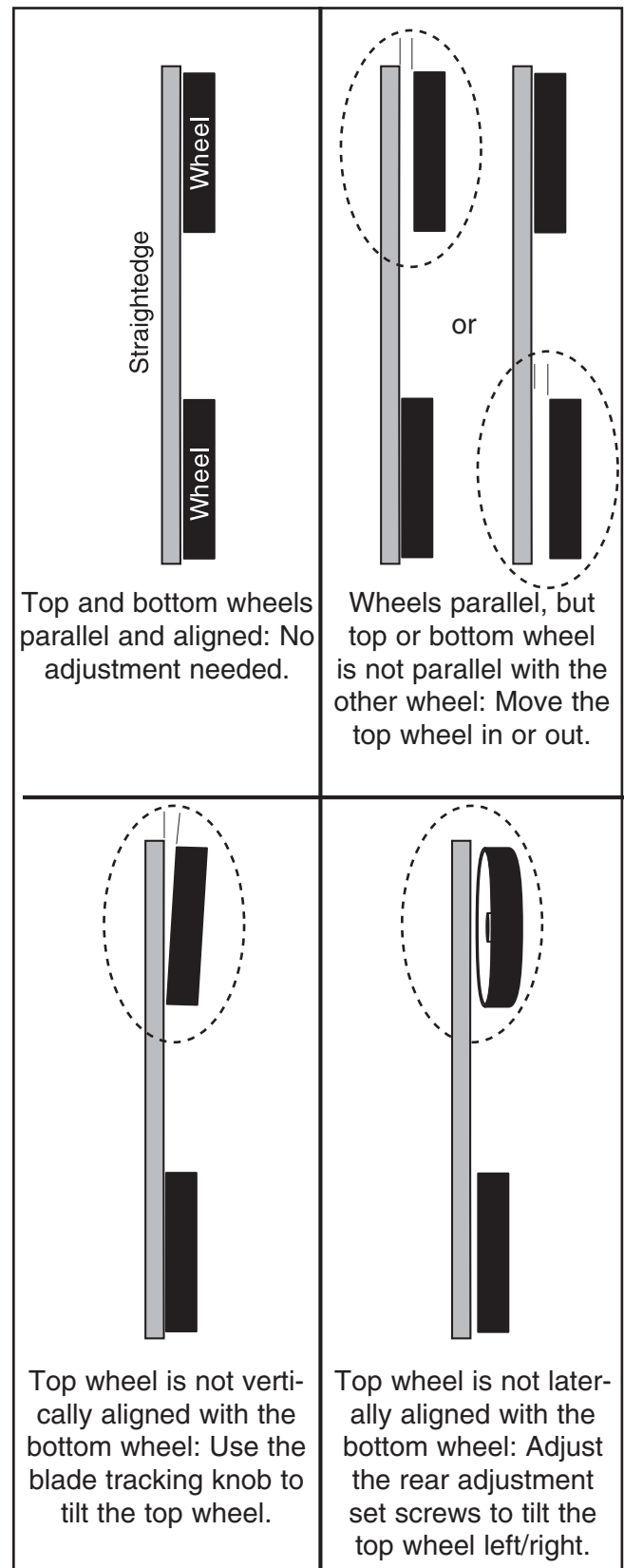

Figure 60. Wheel alignment illustration.



Shimming a Wheel

A wheel that is parallel with the other wheel, but is not coplanar, must be shimmed by the distance that it is not in the same plane with the other wheel.

Tip: *Thin washers work well for shimming the wheel because they can easily be stacked to get the desired height.*

To shim a wheel:

1. DISCONNECT MACHINE FROM POWER!
2. Adjust upper wheel tracking so that it is parallel with bottom wheel.
3. With straightedge touching both rims of wheel that does not need to be adjusted, measure distance away from other wheel with a fine ruler, as shown in **Figure 61**. The distance measured with ruler is the distance this wheel must be shimmed.

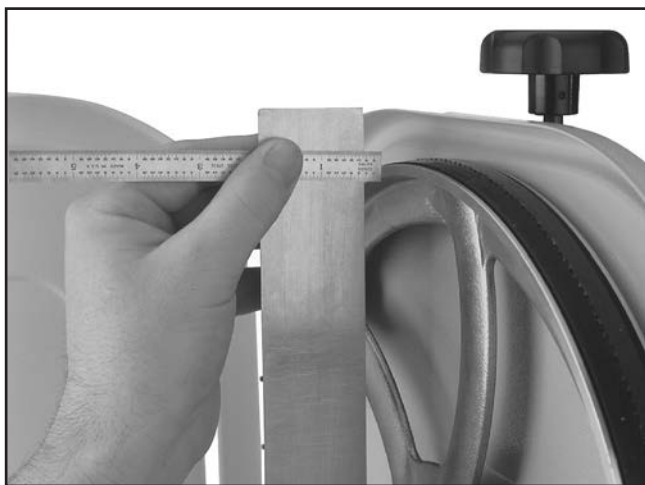

Figure 61. Measuring the distance to shim the wheel to be coplanar.

4. Remove blade.
5. Remove wheel to be shimmed. Place as many shims as necessary to correct the gap measured in **Step 3** onto the wheel shaft.
6. Re-install wheel and secure it in place.
7. Re-install blade and properly tension it.
8. Perform previous **Wheel Alignment** procedure (refer to **Page 50** for instructions). If necessary to make wheels parallel, repeat this procedure.
9. Close wheel covers.

Note: *The first time you get wheels coplanar, place a mark on each wheel where you held the straightedge, then use this position again in the future if you need to repeat the procedure. This assures repeated accuracy every time you adjust the wheels.*



Blade Tensioner

The blade tensioner may need to be reset for one of the following reasons:

- The blade tension quick release lever will not move to the right position when the tension scale is correctly adjusted for the installed blade.
- You have installed a blade of a different length and the tensioner needs tightened.

The procedure below describes how to decompress the spring in the blade tensioner to allow the quick release lever to perform its intended purpose. If the tensioner needs tightened, reverse the procedure to get the desired results.

Items Needed	Qty
Hex Wrench 2.5mm.....	1

To reset blade tensioner:

1. DISCONNECT BANDSAW FROM POWER!
2. Release tension lever shown in **Figure 62** and remove bandsaw blade.

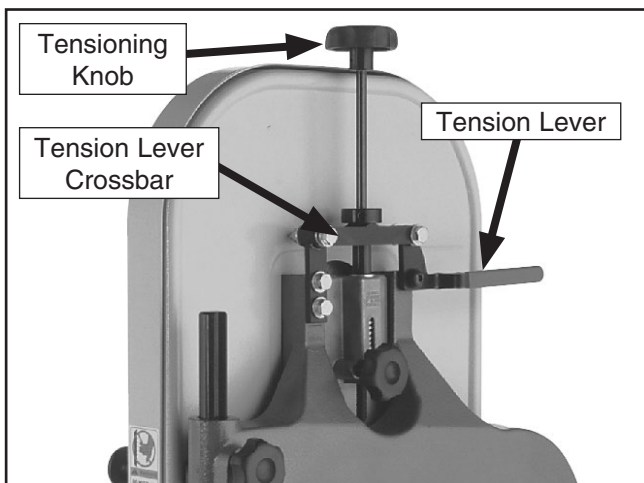

Figure 62. Blade tension controls/components.

3. Place the new blade onto the wheels and between the blade guide bearings.

Note: A new blade is used to calibrate the tensioner because it is unstretched.

4. Loosen the set screws in both of the spacers indicated in **Figure 63**.
5. Back the spacers away from the tension lever crossbar shown in **Figure 62**.

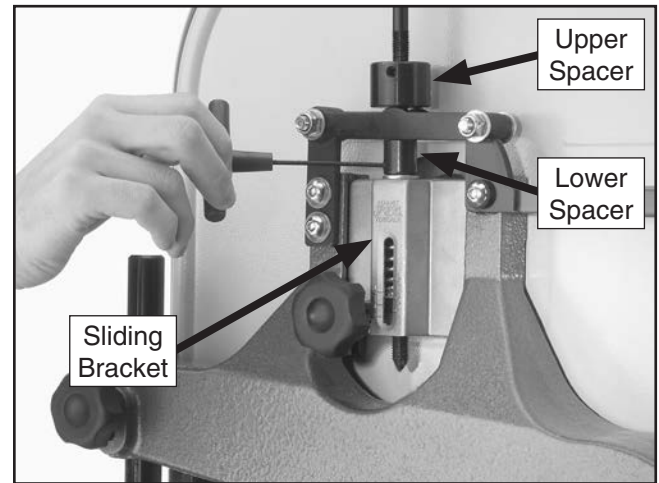

Figure 63. Loosening the spacer set screws.

6. Pull the tension lever down to the horizontal position.
7. Pull up on the tensioning knob (see **Figure 62**) until the blade touches the wheel.
8. Thread the upper spacer down until it touches the top of the tension lever crossbar.
9. Tighten the set screw on the upper spacer.
10. Tension the blade (refer to **Page 23**).
11. Thread the lower spacer down until it touches the top of the sliding bracket indicated in **Figure 63**.
12. Move the lower spacer back up the shaft about 1-2 turns to leave a small space, and tighten the set screw (see **Figure 63**).
13. Make sure there is no tension on the blade when the lever is released. If all the tension is not released, the lower spacer needs to be threaded farther down the shaft toward the sliding bracket.



SECTION 8: WIRING

These pages are current at the time of printing. However, in the spirit of improvement, we may make changes to the electrical systems of future machines. Compare the manufacture date of your machine to the one stated in this manual, and study this section carefully.

If there are differences between your machine and what is shown in this section, call Technical Support at (570) 546-9663 for assistance BEFORE making any changes to the wiring on your machine. An updated wiring diagram may be available. **Note:** *Please gather the serial number and manufacture date of your machine before calling. This information can be found on the main machine label.*

WARNING

Wiring Safety Instructions

SHOCK HAZARD. Working on wiring that is connected to a power source is extremely dangerous. Touching electrified parts will result in personal injury including but not limited to severe burns, electrocution, or death. Disconnect the power from the machine before servicing electrical components!

MODIFICATIONS. Modifying the wiring beyond what is shown in the diagram may lead to unpredictable results, including serious injury or fire. This includes the installation of unapproved after-market parts.

WIRE CONNECTIONS. All connections must be tight to prevent wires from loosening during machine operation. Double-check all wires disconnected or connected during any wiring task to ensure tight connections.

CIRCUIT REQUIREMENTS. You MUST follow the requirements at the beginning of this manual when connecting your machine to a power source.

WIRE/COMPONENT DAMAGE. Damaged wires or components increase the risk of serious personal injury, fire, or machine damage. If you notice that any wires or components are damaged while performing a wiring task, replace those wires or components.

MOTOR WIRING. The motor wiring shown in these diagrams is current at the time of printing but may not match your machine. If you find this to be the case, use the wiring diagram inside the motor junction box.















CAPACITORS/INVERTERS. Some capacitors and power inverters store an electrical charge for up to 10 minutes after being disconnected from the power source. To reduce the risk of being shocked, wait at least this long before working on capacitors.

EXPERIENCING DIFFICULTIES. If you are experiencing difficulties understanding the information included in this section, contact our Technical Support at (570) 546-9663.

NOTICE

The photos and diagrams included in this section are best viewed in color. You can view these pages in color at www.grizzly.com.

COLOR KEY

BLACK 	BLUE 	YELLOW 	LIGHT BLUE 
WHITE 	BROWN 	YELLOW GREEN 	BLUE WHITE 
GREEN 	GRAY 	PURPLE 	TURQUOISE 
RED 	ORANGE 	PINK 	



110V Wiring Diagram

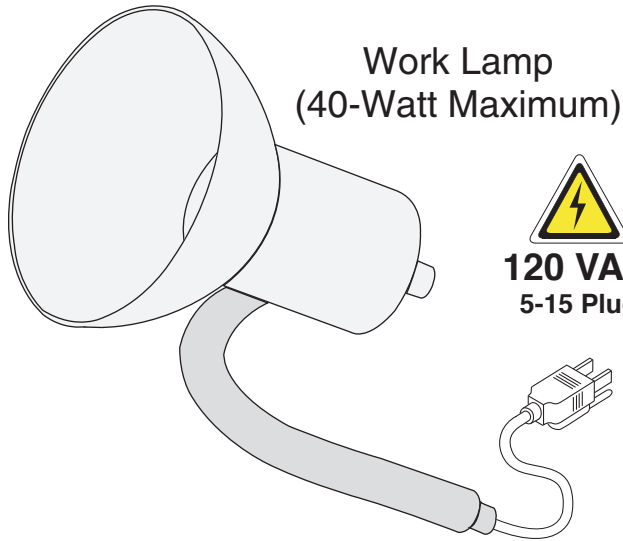

ON/OFF Switch
(viewed from behind)

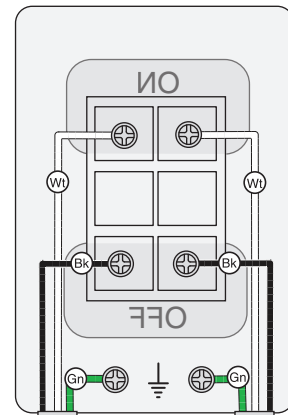

110 VAC
5-15 Plug

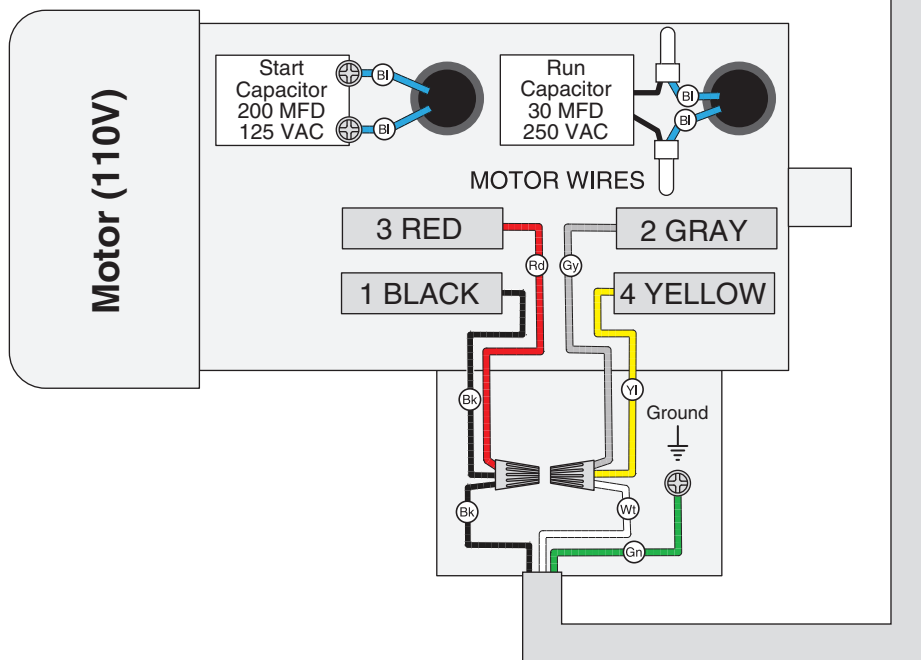
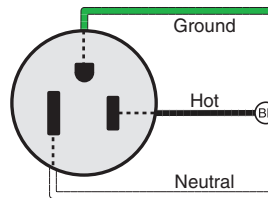

220V Wiring Diagram

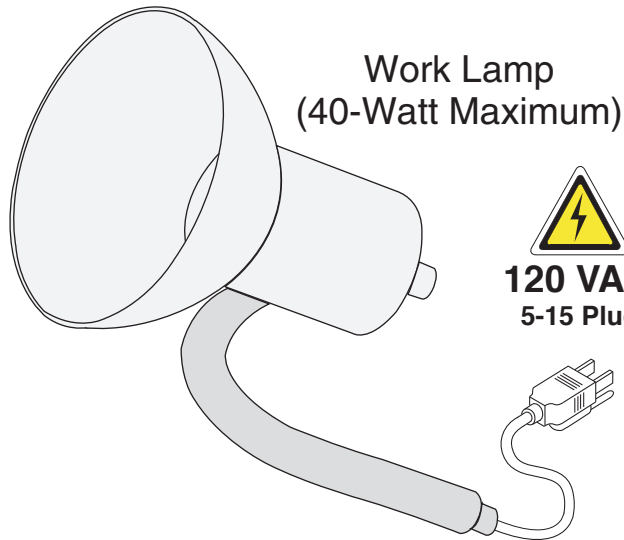

ON/OFF Switch
(viewed from behind)

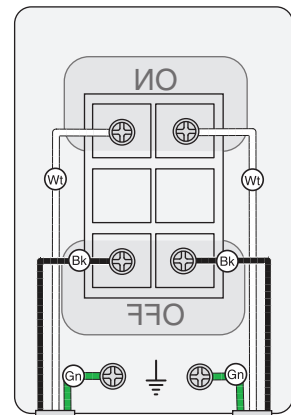

220 VAC
6-15 Plug
(As Recommended)

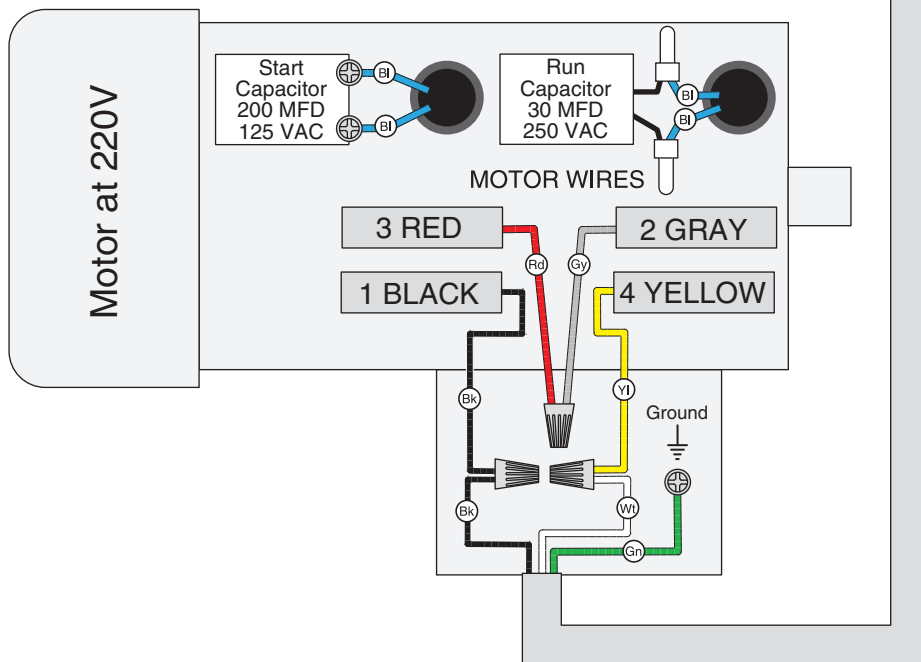
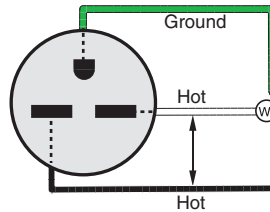

SECTION 9: PARTS

Main

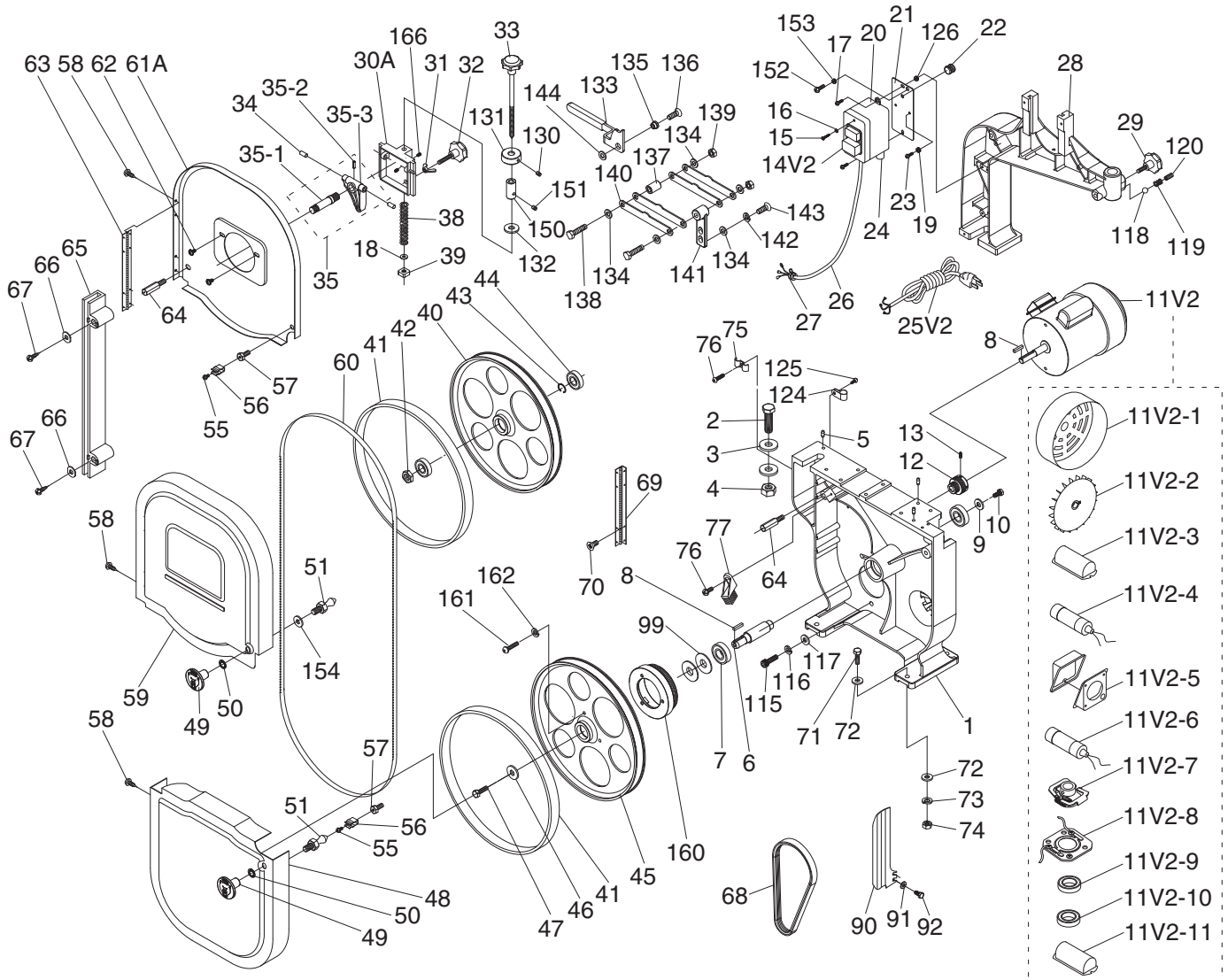

Main Parts List

REF	PART #	DESCRIPTION
1	P0555X001	BASE
2	P0555X002	HEX BOLT M16-2 X 55
3	P0555X003	FLAT WASHER 16MM
4	P0555X004	HEX NUT M16-2
5	P0555X005	ALIGNMENT PIN
6	P0555X006	LOWER WHEEL SHAFT
7	P0555X007	BALL BEARING 6204-2RS
8	P0555X008	KEY 5 X 5 X 25
9	P0555X009	FENDER WASHER 8MM
10	P0555X010	CAP SCREW M8-1.25 X 16
11V2	P0555X011V2	MOTOR 1.5HP 1PH 110/220V V2.05.11
11V2-1	P0555X011V2-1	MOTOR FAN COVER V2.05.11
11V2-2	P0555X011V2-2	MOTOR FAN V2.05.11
11V2-3	P0555X011V2-3	CAPACITOR COVER V2.05.11
11V2-4	P0555X011V2-4	S CAPACITOR 200M 125V V2.05.11
11V2-5	P0555X011V2-5	MOTOR JUNCTION BOX V2.05.11
11V2-6	P0555X011V2-6	R CAPACITOR 30M 250V 1-3/8 X 2-3/8 V2.05.11
11V2-7	P0555X011V2-7	CENTRIFUGAL SWITCH V2.05.11
11V2-8	P0555X011V2-8	CENTRIFUGAL SWITCH W/CONTACT PLATE V2.05.11
11V2-9	P0555X011V2-9	BALL BEARING 6205ZZ
11V2-10	P0555X011V2-10	BALL BEARING 6203ZZ
11V2-11	P0555X011V2-11	CAPACITOR COVER V2.05.11
12	P0555X012	MOTOR PULLEY
13	P0555X013	SET SCREW M6-1 X 12
14V2	P0555X014V2	ON/OFF SWITCH 110/220V V2.05.11
15	P0555X015	TAP SCREW M3.5 X 12
16	P0555X016	FLAT WASHER 4MM
17	P0555X017	PHLP HD SCR M5-.8 X 16
18	P0555X018	TENSION INDICATOR
19	P0555X019	EXT TOOTH WASHER 5MM
20	P0555X020	SWITCH BOX
21	P0555X021	SWITCH BOX MOUNT PLATE
22	P0555X022	STRAIN RELIEF
23	P0555X023	PHLP HD SCR M5-.8 X 6
24	P0555X024	STRAIN RELIEF TYPE-2 M16-1.5
25V2	P0555X025V2	POWER CORD 14G 3C 6FT 5-15 V2.05.11
26	P0555X026	MOTOR CORD
27	P0555X027	STRAIN RELIEF
28	P0555X028	UPPER FRAME ARM
29	P0555X029	KNOB BOLT M10-1.5 X 30
30A	P0555X030A	UPPER WHEEL BRACKET V2.08.07
31	P0555X031	WING NUT 8MM
32	P0555X032	KNOB BOLT M8-1.25 X 45
33	P0555X033	TENSION KNOB BOLT ASSEMBLY
34	P0555X034	STEEL PIN
35	P0555X035	UPPER WHEEL SHAFT HINGE ASSY
35-1	P0555X035-1	UPPER WHEEL SHAFT
35-2	P0555X035-2	ROLL PIN 4 X 24
35-3	P0555X035-3	UPPER WHEEL SHAFT HINGE
38	P0555X038	COMPRESSION SPRING
39	P0555X039	SQUARE NUT M10-1.5
40	P0555X040	UPPER WHEEL

REF	PART #	DESCRIPTION
41	P0555X041	WHEEL TIRE
42	P0555X042	HEX NUT M12-1.75
43	P0555X043	INT RETAINING RING 35MM
44	P0555X044	BALL BEARING 6202LLU
45	P0555X045	LOWER WHEEL ASSEMBLY
46	P0555X046	FENDER WASHER 8MM
47	P0555X047	HEX BOLT M8-1.25 X 20 LH
48	P0555X048	LOWER WHEEL GUARD
49	P0555X049	GRIZZLY ROUND KNOB M8-1.25
50	P0555X050	INT TOOTH WASHER 8MM
51	P0555X051	LATCH STUD M8-1.25 X 14
55	P0555X055	PHLP HD SCR M5-.8 X 12
56	P0555X056	CATCH
57	P0555X057	ALIGNMENT BOLT
58	P0555X058	TAP SCREW M4 X 8
59	P0555X059	UPPER WHEEL COVER
60	P0555X060	SAW BLADE 6TPI 93-1/2 X 3/8" X .5MM
61A	P0555X061A	UPPER WHEEL BACK COVER V2.08.07
62	P0555X062	FLANGE SCREW M5-.8 X 8
63	P0555X063	UPPER WHEEL COVER HINGE
64	P0555X064	STANDOFF STUD
65	P0555X065	LEFT BLADE GUARD
66	P0555X066	TAP SCREW FLAT WASHER
67	P0555X067	TAP SCREW M3.5 X 16
68	P0555X068	RIBBED V-BELT 200J5
69	P0555X069	LOWER WHEEL COVER HINGE
70	P0555X070	FLAT HD SCR M5-.8 X 10
71	P0555X071	HEX BOLT M8-1.25 X 35
72	P0555X072	FLAT WASHER M8-1.25 X 18
73	P0555X073	LOCK WASHER 8MM
74	P0555X074	HEX NUT M8-1.25
75	P0555X075	CORD CLAMP
76	P0555X076	PHLP HD SCR M5-.8 X 8
77	P0555X077	WHEEL BRUSH
90	P0555X090	RIGHT UPPER BLADE GUARD
91	P0555X091	FLAT WASHER 6MM
92	P0555X092	HEX BOLT M6-1 X 10
99	P0555X099	PULLEY FLAT WASHER
115	P0555X115	CAP SCREW M8-1.25 X 25
116	P0555X116	LOCK WASHER 8MM
117	P0555X117	FENDER WASHER 8MM
118	P0555X118	STEEL BALL
119	P0555X119	COMPRESSION SPRING
120	P0555X120	SET SCREW M10-1.5 X 10
124	P0555X124	CORD CLAMP
125	P0555X125	PHLP HD SCR M5-.8 X 8
126	P0555X126	LOCK NUT M4-.7
130	P0555X130	SET SCREW M5-.8 X 10
131	P0555X131	UPPER LOCK COLLAR
132	P0555X132	FLAT WASHER 10MM
133	P0555X133	TENSION LEVER



Main Parts List (cont.)

REF	PART #	DESCRIPTION
134	P0555X134	FLAT WASHER 8MM
135	P0555X135	BUSHING
136	P0555X136	BUTTON HD CAP SCR M8-1.25 X 20
137	P0555X137	SPACER
138	P0555X138	HEX BOLT M8-1.25 X 40
139	P0555X139	LOCK NUT M8-1.25
140	P0555X140	SUPPORT PLATE
141	P0555X141	PIVOT ARM
142	P0555X142	LOCK WASHER 8MM
143	P0555X143	CAP SCREW M8-1.25 X 20

REF	PART #	DESCRIPTION
144	P0555X144	SPACER 8 X 20MM
150	P0555X150	LOWER LOCK COLLAR
151	P0555X151	SET SCREW M5-.8 X 5
153	P0555X153	EXT TOOTH WASHER 5MM
154	P0555X154	FLAT WASHER 8MM
160	P0555X160	WHEEL PULLEY
161	P0555X161	BUTTON HD CAP SCR 5/16-18 X 3/4
162	P0555X162	LOCK WASHER 6MM
166	P0555X166	SET SCREW M5-.8 X 8



Table, Fence & Guides

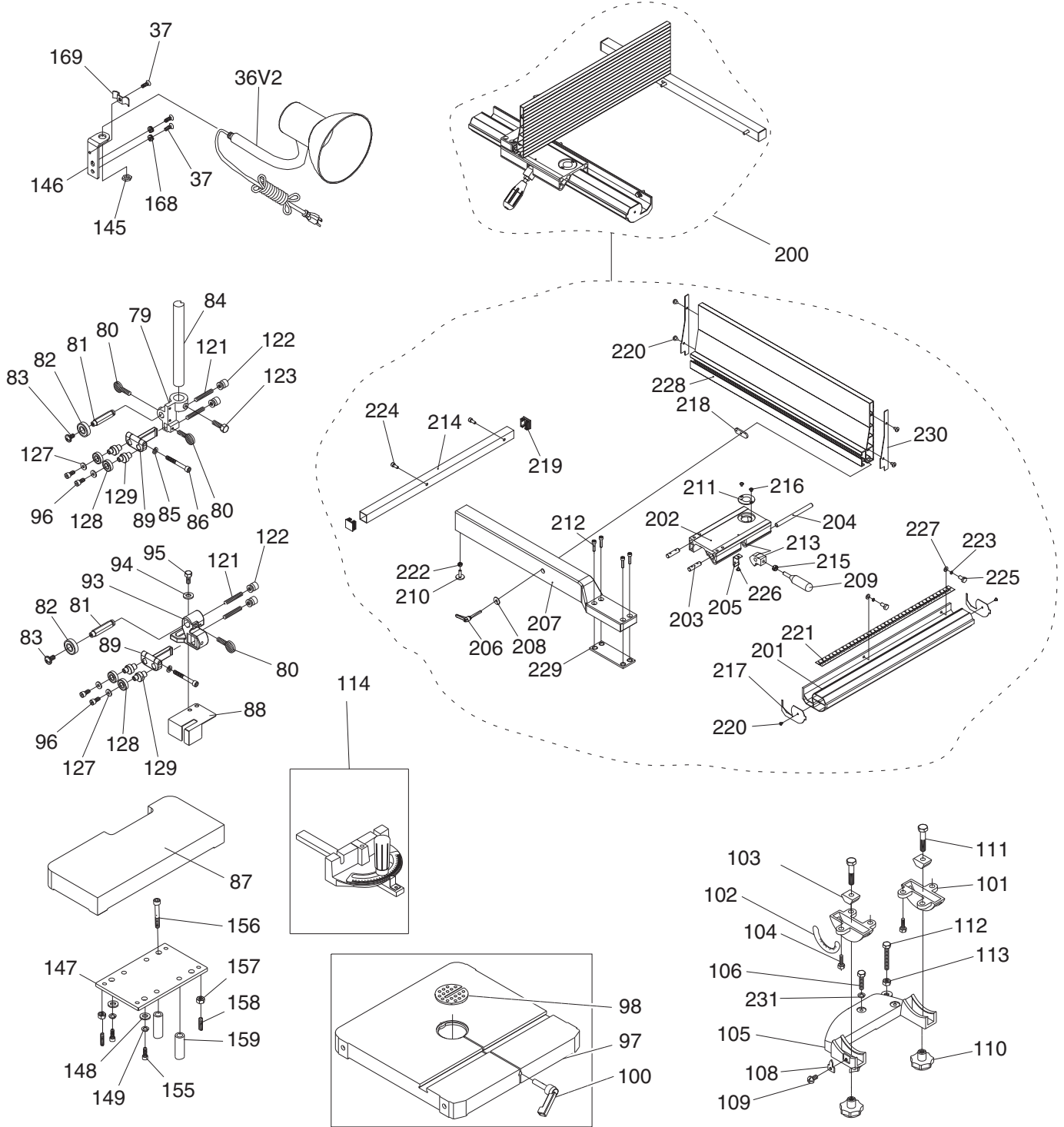

Table, Fence & Guides Parts List

REF	PART #	DESCRIPTION
36V2	P0555X036V2	LAMP ASSY W/POWER CORD V2.04.12
37	P0555X037	FLANGE SCREW M5-.8 X 8
79	P0555X079	UPPER BLADE GUIDE BRACKET
80	P0555X080	THUMB SCREW M6-1 X 16
81	P0555X081	GUIDE SUPPORT SHAFT
82	P0555X082	BALL BEARING 6000Z
83	P0555X083	FLANGE SCREW M6-1 X 8
84	P0555X084	GUIDE POST
85	P0555X085	LOCK WASHER 5MM
86	P0555X086	CAP SCREW M5-.8 X 40
87	P0555X087	TABLE EXTENSION
88	P0555X088	LOWER RIGHT BLADE GUARD
89	P0555X089	GUIDE BEARING SUPPORT BRACKET
93	P0555X093	LOWER BLADE GUIDE BRACKET
94	P0555X094	FLAT WASHER 6MM
95	P0555X095	HEX BOLT M6-1 X 20
96	P0555X096	CAP SCREW M5-.8 X 12
97	P0555X097	TABLE
98	P0555X098	TABLE INSERT
100	P0555X100	TABLE PIN
101	P0555X101	TRUNNION
102	P0555X102	SCALE
103	P0555X103	TRUNNION CLAMP SHOE
104	P0555X104	HEX BOLT M6-1 X 12
105	P0555X105	TRUNNION SUPPORT BRACKET
106	P0555X106	HEX BOLT M8-1.25 X 30
108	P0555X108	POINTER
109	P0555X109	FLANGE SCREW M5-.8 X 6
110	P0555X110	KNOB 10MM
111	P0555X111	TRUNNION HEX BOLT M10-1.5 X 50
112	P0555X112	HEX BOLT M8-1.25 X 80
113	P0555X113	HEX NUT M8-1.25
114	P0555X114	MITER GAUGE BODY ASSEMBLY
121	P0555X121	SET SCREW M8-1 X 35
122	P0555X122	MICRO ADJUSTING NUT
123	P0555X123	HEX BOLT M6-1 X 20
127	P0555X127	FLAT WASHER 5MM
128	P0555X128	BALL BEARING 608ZZ
129	P0555X129	ECCENTRIC BEARING SHAFT
145	P0555X145	LAMP NUT
146	P0555X146	LAMP BRACKET
147	P0555X147	LEVER BOARD

REF	PART #	DESCRIPTION
148	P0555X148	FLAT WASHER 6MM
149	P0555X149	LOCK WASHER 6MM
155	P0555X155	CAP SCREW M6-1 X 25
156	P0555X156	CAP SCREW M8-1.25 x 60
157	P0555X157	HEX NUT M8-1.25
158	P0555X158	SET SCREW M8-1.25 X 20
159	P0555X159	SPACER
168	P0555X168	EXT TOOTH WASHER 5MM
169	P0555X169	CORD CLAMP
200	P0555X200	FENCE KIT ASSEMBLY
201	P0555X201	FRONT FENCE RAIL
202	P0555X202	FENCE BASE
203	P0555X203	FENCE MOUNTING SHAFT
204	P0555X204	LOCK ROD
205	P0555X205	SPRING PIECE
206	P0555X206	LOCK KNOB M8-1.25 X 44
207	P0555X207	FENCE BRACKET
208	P0555X208	FLAT WASHER 8MM
209	P0555X209	LOCK HANDLE
210	P0555X210	FENCE STAND-OFF
211	P0555X211	SCALE WINDOW
212	P0555X212	CAP SCREW M6-1 X 25
213	P0555X213	LOCK CAM
214	P0555X214	REAR FENCE RAIL
215	P0555X215	HEX NUT M8-1.25
216	P0555X216	FLANGE SCREW M4-.7 X 6
217	P0555X217	FRONT RAIL END CAP
218	P0555X218	FENCE MOUNTING KEY
219	P0555X219	REAR RAIL END CAP
220	P0555X220	TAP SCREW M3.5 X 8
221	P0555X221	SCALE
222	P0555X222	HEX NUT M6-1
223	P0555X223	LOCK WASHER 6MM
224	P0555X224	CAP SCREW M6-1 X 16
225	P0555X225	HEX BOLT M6-1 X 20
226	P0555X226	FLANGE SCREW M4-.7 X 8
227	P0555X227	FLAT WASHER 6MM
228	P0555X228	FENCE
229	P0555X229	FENCE BRACKET MOUNTING PLATE
230	P0555X230	FENCE END CAP
231	P0555X231	LOCK WASHER 8MM



Stand

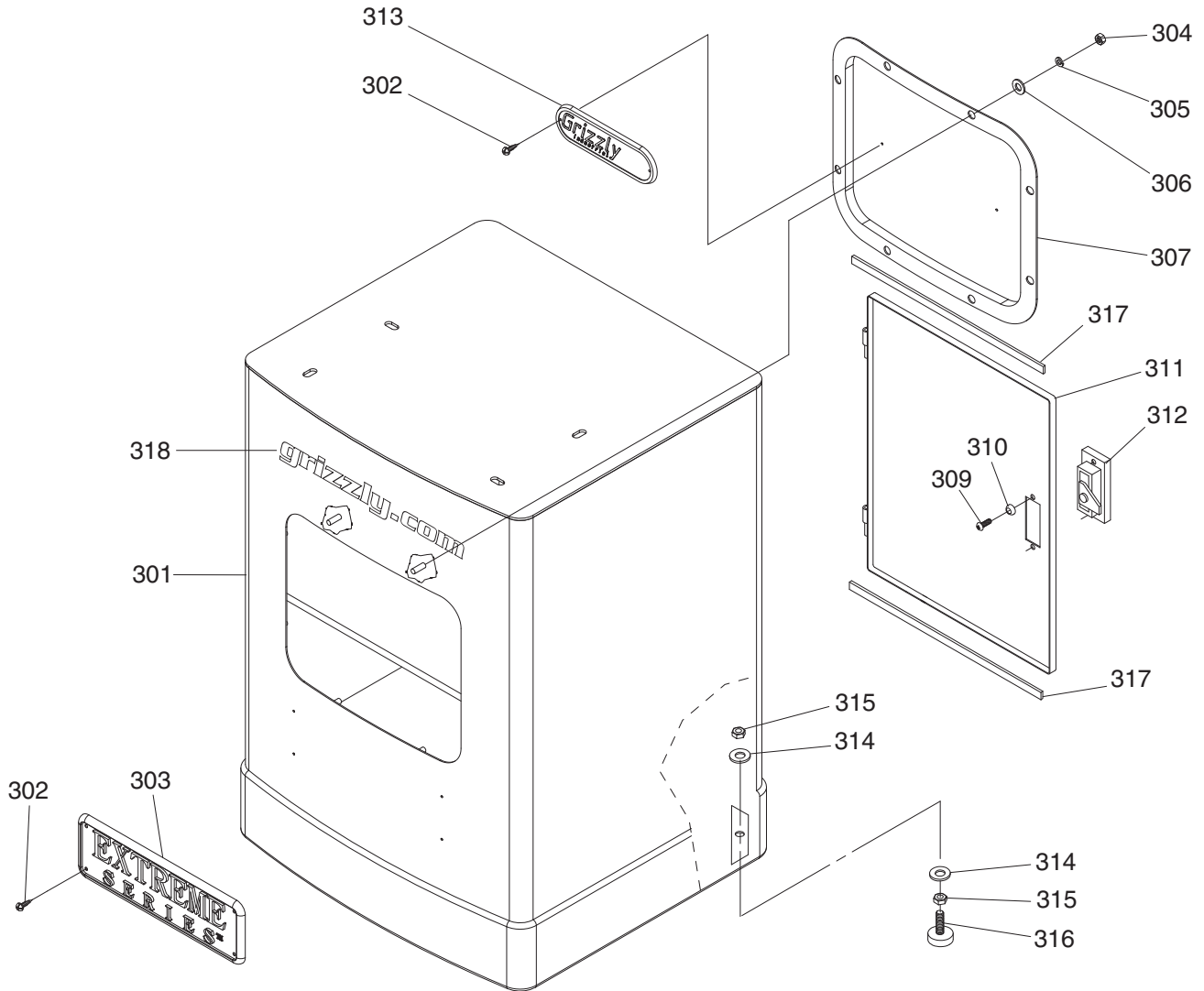

REF	PART #	DESCRIPTION
301	P0555X301	STAND
302	P0555X302	TAP SCREW M3.5 X 8
303	P0555X303	EXTREME SERIES LOGO
304	P0555X304	HEX NUT M6-1
305	P0555X305	LOCK WASHER 6MM
306	P0555X306	FLAT WASHER 6MM
307	P0555X307	FRONT STAND PANEL
309	P0555X309	PHLP HD SCR M4-.7 X 6
310	P0555X310	FLAT WASHER 4MM

REF	PART #	DESCRIPTION
311	P0555X311	DOOR
312	P0555X312	DOOR LATCH ASSEMBLY
313	P0555X313	GRIZZLY LOGO PLATE
314	P0555X314	FLAT WASHER 10MM
315	P0555X315	HEX NUT 3/8-16
316	P0555X316	STAND FOOT
317	P0555X317	DOOR CUSHION
318	P0555X318	GRIZZLY.COM LABEL



Labels & Cosmetics

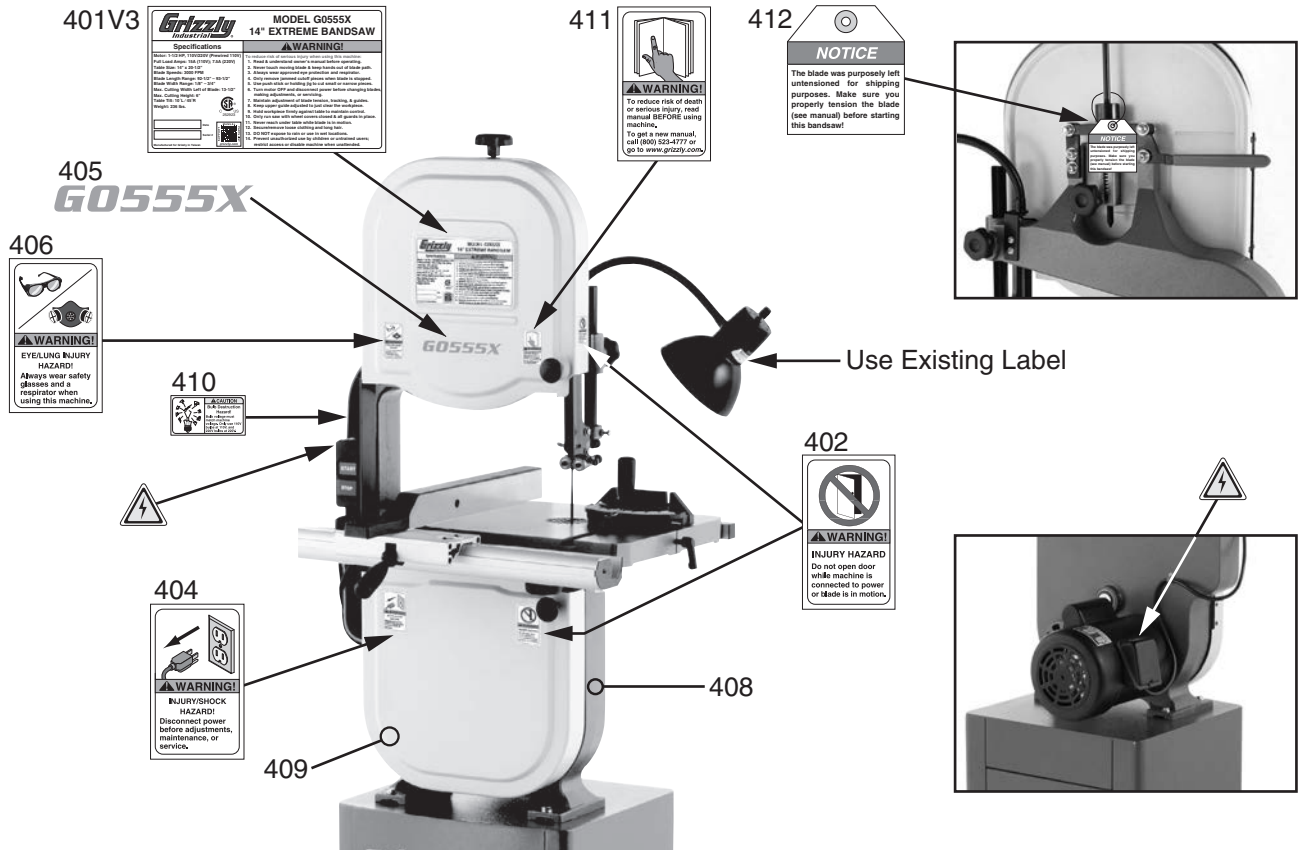

REF	PART #	DESCRIPTION
401V3	P0555X401V3	MACHINE ID LABEL V3.07.13
402	P0555X402	DONT OPEN DOOR LABEL
404	P0555X404	INJURY/SHOCK HAZARD LABEL
405	P0555X405	MODEL NUMBER LABEL
406	P0555X406	GLASSES/RESPIRATOR LABEL

REF	PART #	DESCRIPTION
408	P0555X408	TOUCH-UP PAINT, GRIZZLY GREEN
409	P0555X409	TOUCH-UP PAINT, GRIZZLY PUTTY
410	P0555X410	BULB DESTRUCTION LABEL
411	P0555X411	READ MANUAL LABEL
412	P0555X412	TENSIONER NOTICE LABEL

⚠ WARNING

Safety labels help reduce the risk of serious injury caused by machine hazards. If any label comes off or becomes unreadable, the owner of this machine **MUST** replace it in the original location before resuming operations. For replacements, contact (800) 523-4777 or www.grizzly.com.





WARRANTY CARD

Name _____
 Street _____
 City _____ State _____ Zip _____
 Phone # _____ Email _____
 Model # _____ Order # _____ Serial # _____

The following information is given on a voluntary basis. It will be used for marketing purposes to help us develop better products and services. **Of course, all information is strictly confidential.**

1. How did you learn about us?

Advertisement Friend Catalog
 Card Deck Website Other:

2. Which of the following magazines do you subscribe to?

<input type="checkbox"/> Cabinetmaker & FDM	<input type="checkbox"/> Popular Science	<input type="checkbox"/> Wooden Boat
<input type="checkbox"/> Family Handyman	<input type="checkbox"/> Popular Woodworking	<input type="checkbox"/> Woodshop News
<input type="checkbox"/> Hand Loader	<input type="checkbox"/> Precision Shooter	<input type="checkbox"/> Woodsmith
<input type="checkbox"/> Handy	<input type="checkbox"/> Projects in Metal	<input type="checkbox"/> Woodwork
<input type="checkbox"/> Home Shop Machinist	<input type="checkbox"/> RC Modeler	<input type="checkbox"/> Woodworker West
<input type="checkbox"/> Journal of Light Cont.	<input type="checkbox"/> Rifle	<input type="checkbox"/> Woodworker's Journal
<input type="checkbox"/> Live Steam	<input type="checkbox"/> Shop Notes	<input type="checkbox"/> Other:
<input type="checkbox"/> Model Airplane News	<input type="checkbox"/> Shotgun News	
<input type="checkbox"/> Old House Journal	<input type="checkbox"/> Today's Homeowner	
<input type="checkbox"/> Popular Mechanics	<input type="checkbox"/> Wood	

3. What is your annual household income?

\$20,000-\$29,000 \$30,000-\$39,000 \$40,000-\$49,000
 \$50,000-\$59,000 \$60,000-\$69,000 \$70,000+

4. What is your age group?

20-29 30-39 40-49
 50-59 60-69 70+

5. How long have you been a woodworker/metalworker?

0-2 Years 2-8 Years 8-20 Years 20+ Years

6. How many of your machines or tools are Grizzly?

0-2 3-5 6-9 10+

7. Do you think your machine represents a good value? Yes No

8. Would you recommend Grizzly Industrial to a friend? Yes No

9. Would you allow us to use your name as a reference for Grizzly customers in your area?
Note: We never use names more than 3 times. Yes No

10. Comments: _____

CUT ALONG DOTTED LINE

FOLD ALONG DOTTED LINE



Place
Stamp
Here



GRIZZLY INDUSTRIAL, INC.
P.O. BOX 2069
BELLINGHAM, WA 98227-2069



FOLD ALONG DOTTED LINE

Send a Grizzly Catalog to a friend:

Name _____

Street _____

City _____ State _____ Zip _____

TAPE ALONG EDGES--PLEASE DO NOT STAPLE

WARRANTY AND RETURNS

Grizzly Industrial, Inc. warrants every product it sells for a period of **1 year** to the original purchaser from the date of purchase. This warranty does not apply to defects due directly or indirectly to misuse, abuse, negligence, accidents, repairs or alterations or lack of maintenance. This is Grizzly's sole written warranty and any and all warranties that may be implied by law, including any merchantability or fitness, for any particular purpose, are hereby limited to the duration of this written warranty. We do not warrant or represent that the merchandise complies with the provisions of any law or acts unless the manufacturer so warrants. In no event shall Grizzly's liability under this warranty exceed the purchase price paid for the product and any legal actions brought against Grizzly shall be tried in the State of Washington, County of Whatcom.

We shall in no event be liable for death, injuries to persons or property or for incidental, contingent, special, or consequential damages arising from the use of our products.

To take advantage of this warranty, contact us by mail or phone and give us all the details. We will then issue you a "Return Number," which must be clearly posted on the outside as well as the inside of the carton. We will not accept any item back without this number. Proof of purchase must accompany the merchandise.

The manufacturers reserve the right to change specifications at any time because they constantly strive to achieve better quality equipment. We make every effort to ensure that our products meet high quality and durability standards and we hope you never need to use this warranty.

Please feel free to write or call us if you have any questions about the machine or the manual.

Thank you again for your business and continued support. We hope to serve you again soon.

grizzly.com[®]

TOOL WEBSITE

Buy Direct and Save with Grizzly[®] – Trusted, Proven and a Great Value!
~Since 1983~

*Visit Our Website Today For
Current Specials!*

**ORDER
24 HOURS A DAY!
1-800-523-4777**

