

# *Grizzly* *Industrial, Inc.*®

## **MODEL G0457** **14" INDUSTRIAL BANDSAW** **OWNER'S MANUAL** *(For models manufactured since 05/11)*



COPYRIGHT © AUGUST, 2005 BY GRIZZLY INDUSTRIAL, INC. REVISED JUNE, 2018 (BLHE)  
**WARNING: NO PORTION OF THIS MANUAL MAY BE REPRODUCED IN ANY SHAPE  
OR FORM WITHOUT THE WRITTEN APPROVAL OF GRIZZLY INDUSTRIAL, INC.**  
#TR7412 PRINTED IN TAIWAN



## **WARNING!**

**This manual provides critical safety instructions on the proper setup, operation, maintenance, and service of this machine/tool. Save this document, refer to it often, and use it to instruct other operators.**

**Failure to read, understand and follow the instructions in this manual may result in fire or serious personal injury—including amputation, electrocution, or death.**

**The owner of this machine/tool is solely responsible for its safe use. This responsibility includes but is not limited to proper installation in a safe environment, personnel training and usage authorization, proper inspection and maintenance, manual availability and comprehension, application of safety devices, cutting/sanding/grinding tool integrity, and the usage of personal protective equipment.**

**The manufacturer will not be held liable for injury or property damage from negligence, improper training, machine modifications or misuse.**



## **WARNING!**

**Some dust created by power sanding, sawing, grinding, drilling, and other construction activities contains chemicals known to the State of California to cause cancer, birth defects or other reproductive harm. Some examples of these chemicals are:**

- **Lead from lead-based paints.**
- **Crystalline silica from bricks, cement and other masonry products.**
- **Arsenic and chromium from chemically-treated lumber.**

**Your risk from these exposures varies, depending on how often you do this type of work. To reduce your exposure to these chemicals: Work in a well ventilated area, and work with approved safety equipment, such as those dust masks that are specially designed to filter out microscopic particles.**

# Table of Contents

<b>INTRODUCTION</b> .....	<b>2</b>	<b>SECTION 5: ACCESSORIES</b> .....	<b>37</b>
Contact Info.....	2	<b>SECTION 6: MAINTENANCE</b> .....	<b>40</b>
Manual Accuracy .....	2	Schedule .....	40
Identification.....	3	Cleaning & Protecting .....	40
Machine Data Sheet .....	4	Lubrication .....	40
<b>SECTION 1: SAFETY</b> .....	<b>6</b>	Redressing Rubber Tires.....	42
Safety Instructions for Machinery .....	6	<b>SECTION 7: SERVICE</b> .....	<b>43</b>
Additional Safety for Bandsaws .....	8	Troubleshooting .....	43
<b>SECTION 2: POWER SUPPLY</b> .....	<b>9</b>	Checking V-Belt .....	45
Disabling & Locking Switch.....	11	Tensioning V-Belt.....	45
<b>SECTION 3: SETUP</b> .....	<b>12</b>	Replacing V-Belt .....	46
Needed for Setup.....	12	Shimming Table .....	47
Unpacking .....	12	Blade Lead.....	47
Hardware Recognition Chart .....	13	Wheel Alignment.....	49
Inventory .....	14	<b>SECTION 8: WIRING</b> .....	<b>51</b>
Clean Up.....	15	Wiring Safety Instructions .....	51
Site Considerations.....	15	Wiring Diagram .....	52
Assembly .....	16	<b>SECTION 9: PARTS</b> .....	<b>53</b>
Dust Collection.....	19	Main .....	53
Blade Tracking.....	20	Components.....	56
Test Run .....	21	Stand.....	57
Table Stop Calibration .....	21	Labels .....	58
Table Tilt Calibration.....	22	<b>WARRANTY &amp; RETURNS</b> .....	<b>61</b>
Table Alignment.....	22		
Fence Alignment.....	23		
Miter Gauge .....	23		
Blade Tensioning .....	24		
Adjusting Support Bearings .....	24		
Blade Guide Adjustments .....	26		
<b>SECTION 4: OPERATIONS</b> .....	<b>27</b>		
Basic Controls.....	27		
Overview .....	28		
Workpiece Inspection.....	29		
Table Tilt .....	29		
Guide Post.....	30		
Ripping.....	30		
Crosscutting.....	31		
Resawing .....	31		
Cutting Curves .....	32		
Stacked Cuts.....	33		
Blade Information.....	34		
Blade Changes .....	36		

# INTRODUCTION

## Contact Info

We stand behind our machines! If you have questions or need help, contact us with the information below. Before contacting, make sure you get the **serial number** and **manufacture date** from the machine ID label. This will help us help you faster.

Grizzly Technical Support  
1815 W. Battlefield  
Springfield, MO 65807  
Phone: (570) 546-9663  
Email: techsupport@grizzly.com

We want your feedback on this manual. What did you like about it? Where could it be improved? Please take a few minutes to give us feedback.

Grizzly Documentation Manager  
P.O. Box 2069  
Bellingham, WA 98227-2069  
Email: manuals@grizzly.com

### **WARNING**

Like all machinery there is potential danger when operating this machine. Accidents are frequently caused by lack of familiarity or failure to pay attention. Use this machine with respect and caution to lessen the possibility of operator injury. If normal safety precautions are overlooked or ignored, serious personal injury may occur.



## Manual Accuracy

We are proud to provide a high-quality owner's manual with your new machine!

We made every effort to be exact with the instructions, specifications, drawings, and photographs in this manual. Sometimes we make mistakes, but our policy of continuous improvement also means that **sometimes the machine you receive is slightly different than shown in the manual.**

If you find this to be the case, and the difference between the manual and machine leaves you confused or unsure about something, check our website for an updated version. We post current manuals and manual updates for free on our website at [www.grizzly.com](http://www.grizzly.com).

Alternatively, you can call our Technical Support for help. Before calling, make sure you write down the **Manufacture Date** and **Serial Number** from the machine ID label (see below). This information is required for us to provide proper tech support, and it helps us determine if updated documentation is available for your machine.

		MODEL GXXXX MACHINE NAME
SPECIFICATIONS		 <b>WARNING!</b>
Motor:	To reduce risk of serious injury when using this machine:	
Specification:	Read manual before operation.	
Specification:	Wear safety glasses and respirator.	
Specification:	Ensure safety is correctly adjusted/setup and	
Weight:	power is connected to grounded circuit before starting.	
	4. Make sure the motor has stopped and disconnect	
	5. DO NOT expose to rain or dampness.	
	6. DO NOT modify this machine in any way.	
	7.	
	8.	
	9. Do not use while under the influence of drugs or alcohol.	
	10. Maintain machine carefully to prevent accidents.	
Manufactured for Grizzly in Taiwan		

**Manufacture Date** [ ]

**Serial Number** [ ]



# Identification

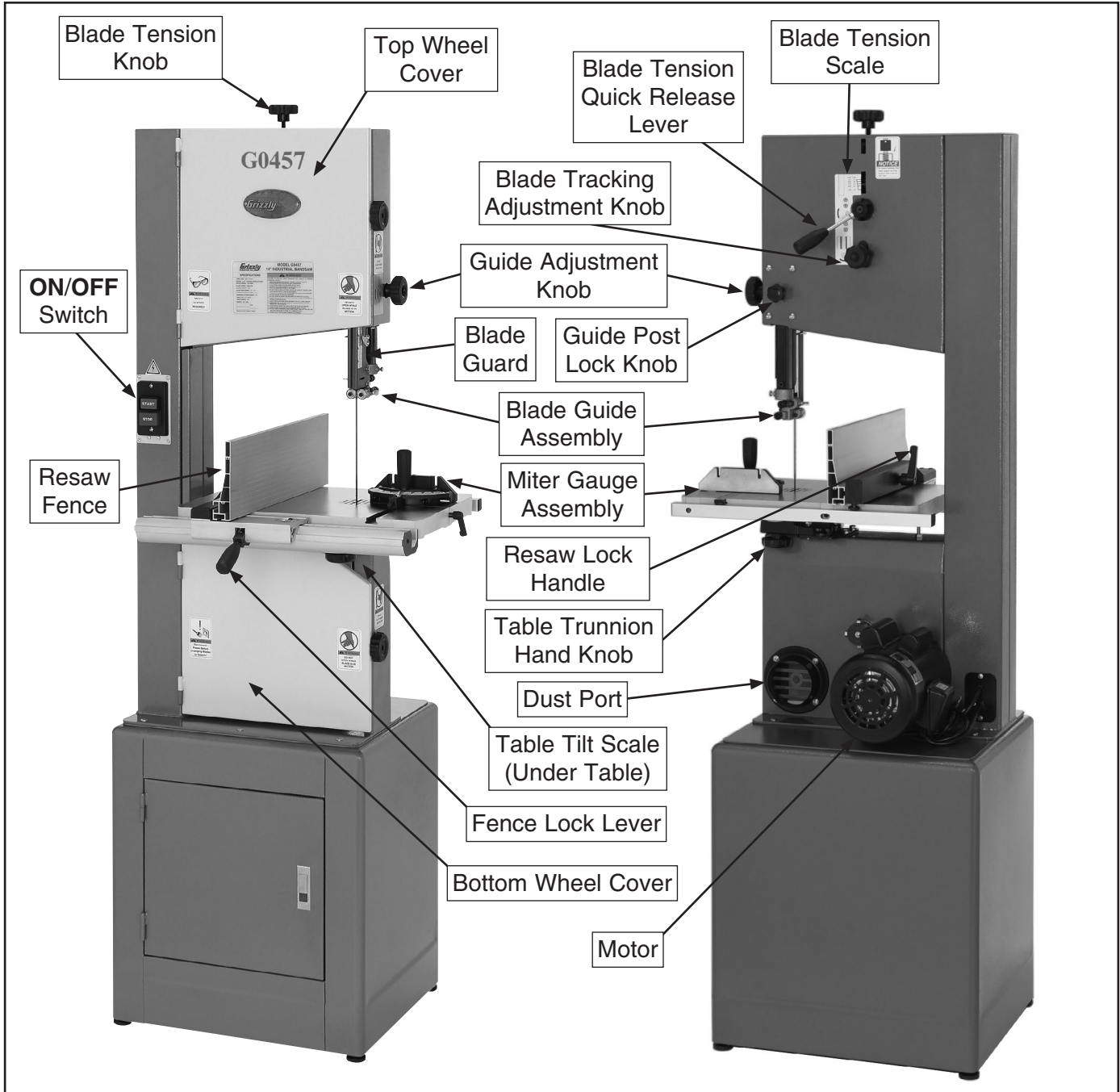

## WARNING

For Your Own Safety, Read Instruction Manual Before Operating Bandsaw

- Wear eye protection.
- Do not remove jammed cutoff pieces until blade has stopped.
- Maintain proper adjustment of blade tension, blade guides, and thrust bearings.
- Adjust upper guide to just clear workpiece.
- Hold workpiece firmly against table.





# MACHINE DATA SHEET

Customer Service #: (570) 546-9663 · To Order Call: (800) 523-4777 · Fax #: (800) 438-5901

## MODEL G0457 14" 2 HP DELUXE BANDSAW

### Product Dimensions:

Weight..... 251 lbs.  
 Width (side-to-side) x Depth (front-to-back) x Height..... 29-3/4 x 29-1/2 x 73 in.  
 Footprint (Length x Width)..... 21-1/2 x 18-1/4 in.

### Shipping Dimensions:

#### Carton #1

Type..... Cardboard Box  
 Content..... Machine  
 Weight..... 214 lbs.  
 Length x Width x Height..... 51 x 23 x 14 in.  
 Must Ship Upright..... No

#### Carton #2

Type..... Cardboard Box  
 Content..... Stand  
 Weight..... 70 lbs.  
 Length x Width x Height..... 22 x 19 x 25 in.  
 Must Ship Upright..... No

### Electrical:

Power Requirement..... 110V or 220V, Single-Phase, 60 Hz  
 Prewired Voltage..... 220V  
 Full-Load Current Rating..... 19A at 110V, 9.5A at 220V  
 Minimum Circuit Size..... 20A at 110V, 15A at 220V  
 Connection Type..... Cord & Plug  
 Power Cord Included..... Yes  
 Power Cord Length..... 7 ft.  
 Power Cord Gauge..... 14 AWG  
 Plug Included..... Yes  
 Included Plug Type..... 6-15 for 220V  
 Recommended Plug Type..... 5-20 for 110V  
 Switch Type..... ON/OFF Push Button Switch w/Padlock

### Motors:

#### Main

Horsepower..... 2 HP  
 Phase..... Single-Phase  
 Amps..... 19A/9.5A  
 Speed..... 1725 RPM  
 Type..... TEFC Capacitor-Start Induction  
 Power Transfer ..... Poly-V Belt Drive  
 Bearings..... Sealed & Permanently Lubricated  
 Centrifugal Switch/Contacts Type..... External



**Main Specifications:**

**Main Specifications**

Bandsaw Size.....	14 in.
Max Cutting Width (Left of Blade).....	13-1/2 in.
Max Cutting Width (Left of Blade) w/Fence.....	12-1/4 in.
Max Cutting Height (Resaw Height).....	10 in.
Blade Speeds.....	3000 FPM

**Blade Information**

Standard Blade Length.....	106 in.
Blade Length Range.....	105-3/4 – 107-1/4 in.
Blade Width Range.....	1/8 – 3/4 in.
Type of Blade Guides.....	Ball Bearing
Guide Post Adjustment Type.....	Rack & Pinion
Has Quick-Release.....	Yes

**Table Information**

Table Length.....	19-3/4 in.
Table Width.....	14-3/16 in.
Table Thickness.....	1-1/2 in.
Table Tilt.....	Left 8, Right 45 deg.
Table Tilt Adjustment Type.....	Manual
Floor-to-Table Height.....	42-1/4 in.
Fence Locking Position.....	Front
Fence is Adjustable for Blade Lead.....	Yes
Resaw Fence Attachment Included.....	Yes
Miter Gauge Included.....	Yes

**Construction Materials**

Table.....	Precision Ground Cast Iron
Trunnion.....	Cast Iron
Fence.....	Deluxe Extruded Aluminum
Base/Stand.....	Pre-Formed Steel
Frame/Body.....	Pre-Formed Steel
Wheels.....	Computer-Balanced Cast Iron
Tire.....	Urethane
Wheel Cover.....	Pre-Formed Steel
Paint Type/Finish.....	Powder Coated

**Other Related Information**

Wheel Diameter.....	14 in.
Wheel Width.....	1-1/8 in.
Number of Dust Ports.....	1
Dust Port Size.....	4 in.
Compatible Mobile Base.....	D2057A

**Other Specifications:**

Country of Origin.....	Taiwan
Warranty.....	1 Year
Approximate Assembly & Setup Time.....	45 Minutes
Serial Number Location.....	ID Label on Upper Cover
ISO 9001 Factory.....	Yes
Certified by a Nationally Recognized Testing Laboratory (NRTL).....	Yes



# SECTION 1: SAFETY

## For Your Own Safety, Read Instruction Manual Before Operating This Machine

The purpose of safety symbols is to attract your attention to possible hazardous conditions. This manual uses a series of symbols and signal words intended to convey the level of importance of the safety messages. The progression of symbols is described below. Remember that safety messages by themselves do not eliminate danger and are not a substitute for proper accident prevention measures. Always use common sense and good judgment.

 **DANGER** Indicates an imminently hazardous situation which, if not avoided, **WILL** result in death or serious injury.

 **WARNING** Indicates a potentially hazardous situation which, if not avoided, **COULD** result in death or serious injury.

 **CAUTION** Indicates a potentially hazardous situation which, if not avoided, **MAY** result in minor or moderate injury. It may also be used to alert against unsafe practices.

**NOTICE** Alerts the user to useful information about proper operation of the machine to avoid machine damage.

## Safety Instructions for Machinery

### **WARNING**

**OWNER'S MANUAL.** Read and understand this owner's manual **BEFORE** using machine.

**TRAINED OPERATORS ONLY.** Untrained operators have a higher risk of being hurt or killed. Only allow trained/supervised people to use this machine. When machine is not being used, disconnect power, remove switch keys, or lock-out machine to prevent unauthorized use—especially around children. Make your workshop kid proof!

**DANGEROUS ENVIRONMENTS.** Do not use machinery in areas that are wet, cluttered, or have poor lighting. Operating machinery in these areas greatly increases the risk of accidents and injury.

**MENTAL ALERTNESS REQUIRED.** Full mental alertness is required for safe operation of machinery. Never operate under the influence of drugs or alcohol, when tired, or when distracted.

**ELECTRICAL EQUIPMENT INJURY RISKS.** You can be shocked, burned, or killed by touching live electrical components or improperly grounded machinery. To reduce this risk, only allow qualified service personnel to do electrical installation or repair work, and always disconnect power before accessing or exposing electrical equipment.

**DISCONNECT POWER FIRST.** Always disconnect machine from power supply **BEFORE** making adjustments, changing tooling, or servicing machine. This prevents an injury risk from unintended startup or contact with live electrical components.

**EYE PROTECTION.** Always wear ANSI-approved safety glasses or a face shield when operating or observing machinery to reduce the risk of eye injury or blindness from flying particles. Everyday eyeglasses are **NOT** approved safety glasses.



# WARNING

**WEARING PROPER APPAREL.** Do not wear clothing, apparel or jewelry that can become entangled in moving parts. Always tie back or cover long hair. Wear non-slip footwear to reduce risk of slipping and losing control or accidentally contacting cutting tool or moving parts.

**HAZARDOUS DUST.** Dust created by machinery operations may cause cancer, birth defects, or long-term respiratory damage. Be aware of dust hazards associated with each workpiece material. Always wear a NIOSH-approved respirator to reduce your risk.

**HEARING PROTECTION.** Always wear hearing protection when operating or observing loud machinery. Extended exposure to this noise without hearing protection can cause permanent hearing loss.

**REMOVE ADJUSTING TOOLS.** Tools left on machinery can become dangerous projectiles upon startup. Never leave chuck keys, wrenches, or any other tools on machine. Always verify removal before starting!

**USE CORRECT TOOL FOR THE JOB.** Only use this tool for its intended purpose—do not force it or an attachment to do a job for which it was not designed. Never make unapproved modifications—modifying tool or using it differently than intended may result in malfunction or mechanical failure that can lead to personal injury or death!

**AWKWARD POSITIONS.** Keep proper footing and balance at all times when operating machine. Do not overreach! Avoid awkward hand positions that make workpiece control difficult or increase the risk of accidental injury.

**CHILDREN & BYSTANDERS.** Keep children and bystanders at a safe distance from the work area. Stop using machine if they become a distraction.

**GUARDS & COVERS.** Guards and covers reduce accidental contact with moving parts or flying debris. Make sure they are properly installed, undamaged, and working correctly BEFORE operating machine.

**FORCING MACHINERY.** Do not force machine. It will do the job safer and better at the rate for which it was designed.

**NEVER STAND ON MACHINE.** Serious injury may occur if machine is tipped or if the cutting tool is unintentionally contacted.

**STABLE MACHINE.** Unexpected movement during operation greatly increases risk of injury or loss of control. Before starting, verify machine is stable and mobile base (if used) is locked.

**USE RECOMMENDED ACCESSORIES.** Consult this owner's manual or the manufacturer for recommended accessories. Using improper accessories will increase the risk of serious injury.

**UNATTENDED OPERATION.** To reduce the risk of accidental injury, turn machine **OFF** and ensure all moving parts completely stop before walking away. Never leave machine running while unattended.

**MAINTAIN WITH CARE.** Follow all maintenance instructions and lubrication schedules to keep machine in good working condition. A machine that is improperly maintained could malfunction, leading to serious personal injury or death.

**DAMAGED PARTS.** Regularly inspect machine for damaged, loose, or mis-adjusted parts—or any condition that could affect safe operation. Immediately repair/replace BEFORE operating machine. For your own safety, DO NOT operate machine with damaged parts!

**MAINTAIN POWER CORDS.** When disconnecting cord-connected machines from power, grab and pull the plug—NOT the cord. Pulling the cord may damage the wires inside. Do not handle cord/plug with wet hands. Avoid cord damage by keeping it away from heated surfaces, high traffic areas, harsh chemicals, and wet/damp locations.

**EXPERIENCING DIFFICULTIES.** If at any time you experience difficulties performing the intended operation, stop using the machine! Contact our Technical Support at (570) 546-9663.



# Additional Safety for Bandsaws

## WARNING

**Serious cuts, amputation, or death can occur from contact with the moving saw blade during operation or if blade breakage occurs. To reduce this risk, anyone operating this machine MUST completely heed the hazards and warnings below.**

**HAND PLACEMENT.** Placing hands or fingers in line with blade during operation may result in serious injury if hands slip or workpiece moves unexpectedly. Do not position fingers or hands in line with blade, and never reach under table while blade is moving.

**SMALL/NARROW WORKPIECES.** If hands slip during a cut while holding small workpieces with fingers, serious personal injury could occur. Always support/feed small or narrow workpieces with push sticks, push blocks, jig, vise, or some type of clamping fixture.

**UPPER BLADE GUIDE SUPPORT.** To reduce exposure of operator to blade and provide maximum blade support while cutting, keep upper blade guides adjusted to just clear workpiece.

**FEED RATE.** To avoid risk of workpiece slipping and causing operator injury, always feed stock evenly and smoothly.

**BLADE CONDITION.** Dull blades require more effort to perform cut, increasing risk of accidents. Do not operate with dirty, dull, cracked or badly worn blades. Inspect blades for cracks and missing teeth before each use. Always maintain proper blade tension and tracking while operating.

**CLEARING JAMS AND CUTOFFS.** Always stop bandsaw and disconnect power before clearing scrap pieces that get stuck between blade and table insert. Use brush or push stick, not hands, to clean chips/cutoff scraps from table.

**BLADE CONTROL.** To avoid risk of injury due to blade contact, always allow blade to stop on its own. DO NOT try to stop or slow blade with your hand or the workpiece.

**GUARDS/COVERS.** Blade guards and covers protect operator from the moving bandsaw blade. The wheel covers protect operator from getting entangled with rotating wheels or other moving parts. ONLY operate this bandsaw with blade guard in proper position and wheel covers completely closed.

**BLADE SPEED.** Cutting workpiece before blade is at full speed could cause blade to grab workpiece and pull hands into blade. Allow blade to reach full speed before starting cut. DO NOT start machine with workpiece contacting blade.

**CUTTING TECHNIQUES.** To avoid blade getting pulled off wheels or accidentally breaking and striking operator, always turn bandsaw **OFF** and wait for blade to come to a complete stop before backing workpiece out of blade. DO NOT back workpiece away from blade while bandsaw is running. DO NOT force or twist blade while cutting, especially when sawing small curves. This could result in blade damage or breakage.

**WORKPIECE SUPPORT.** To maintain maximum control and reduce risk of blade contact/breakage, always ensure adequate support of long/large workpieces. Always keep workpiece flat and firm against table/fence when cutting to avoid loss of control. If necessary, use a jig or other workholding device.

## WARNING

**No list of safety guidelines can be complete. Every shop environment is different. Always consider safety first, as it applies to your individual working conditions. Use this and other machinery with caution and respect. Failure to do so may result in serious personal injury or property damage.**



# SECTION 2: POWER SUPPLY

## Availability

Before installing the machine, consider the availability and proximity of the required power supply circuit. If an existing circuit does not meet the requirements for this machine, a new circuit must be installed. To minimize the risk of electrocution, fire, or equipment damage, installation work and electrical wiring must be done by an electrician or qualified service personnel in accordance with all applicable codes and standards.

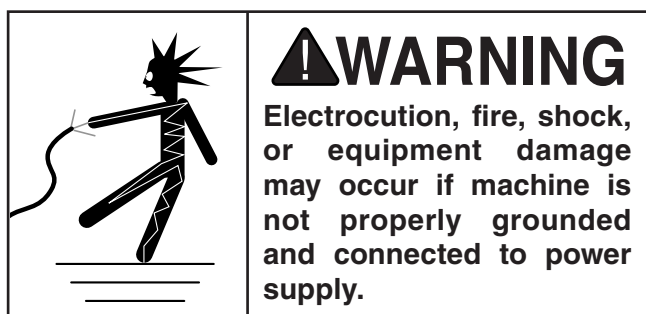

## Full-Load Current Rating

The full-load current rating is the amperage a machine draws at 100% of the rated output power. On machines with multiple motors, this is the amperage drawn by the largest motor or sum of all motors and electrical devices that might operate at one time during normal operations.

**Full-Load Current Rating at 220V .... 9.5 Amps**

**Full-Load Current Rating at 110V..... 19 Amps**

The full-load current is not the maximum amount of amps that the machine will draw. If the machine is overloaded, it will draw additional amps beyond the full-load rating.

If the machine is overloaded for a sufficient length of time, damage, overheating, or fire may result—especially if connected to an undersized circuit. To reduce the risk of these hazards, avoid overloading the machine during operation and make sure it is connected to a power supply circuit that meets the specified circuit requirements.

## Circuit Information

A power supply circuit includes all electrical equipment between the breaker box or fuse panel in the building and the machine. The power supply circuit used for this machine must be sized to safely handle the full-load current drawn from the machine for an extended period of time. (If this machine is connected to a circuit protected by fuses, use a time delay fuse marked D.)

### ⚠ CAUTION

For your own safety and protection of property, consult an electrician if you are unsure about wiring practices or electrical codes in your area.

**Note:** *Circuit requirements in this manual apply to a dedicated circuit—where only one machine will be running on the circuit at a time. If machine will be connected to a shared circuit where multiple machines may be running at the same time, consult an electrician or qualified service personnel to ensure circuit is properly sized for safe operation.*

## Circuit Requirements for 220V

This machine is prewired to operate on a 220V power supply circuit that has a verified ground and meets the following requirements:

**Nominal Voltage** ..... 220V  
**Cycle** ..... 60 Hz  
**Phase** ..... Single-Phase  
**Circuit Rating** ..... 15 Amps  
**Plug/Receptacle** ..... NEMA 6-15

## Circuit Requirements for 110V

This machine can be converted to operate on a 110V power supply (refer to **Voltage Conversion** instructions) that has a verified ground and meets the following requirements:

**Nominal Voltage** ..... 110V  
**Cycle** ..... 60 Hz  
**Phase** ..... Single-Phase  
**Circuit Rating** ..... 20 Amps  
**Plug/Receptacle** ..... NEMA 5-20  
**Cord** ..... “S”-Type, 3-Wire, 12 AWG, 300 VAC



## Grounding Requirements

This machine **MUST** be grounded. In the event of certain malfunctions or breakdowns, grounding reduces the risk of electric shock by providing a path of least resistance for electric current.

**For 220V operation:** This machine is equipped with a power cord that has an equipment-grounding wire and a grounding plug (see following figure). The plug must only be inserted into a matching receptacle (outlet) that is properly installed and grounded in accordance with all local codes and ordinances.

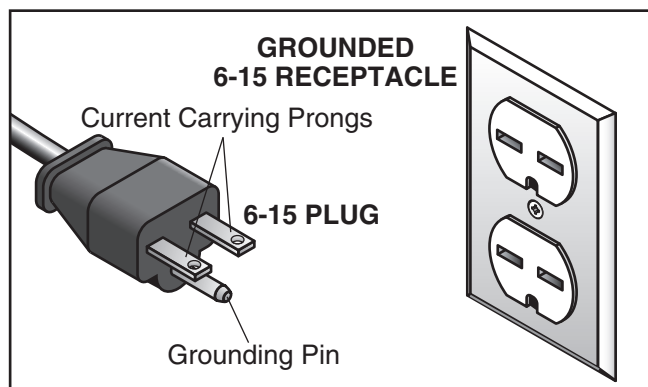

**Figure 1.** Typical 6-15 plug and receptacle.

**For 110V operation:** The plug specified in the circuit requirements has a grounding prong that must be attached to the equipment-grounding wire inside the included power cord. The plug must only be inserted into a matching receptacle (see following figure) that is properly installed and grounded in accordance with all local codes and ordinances.

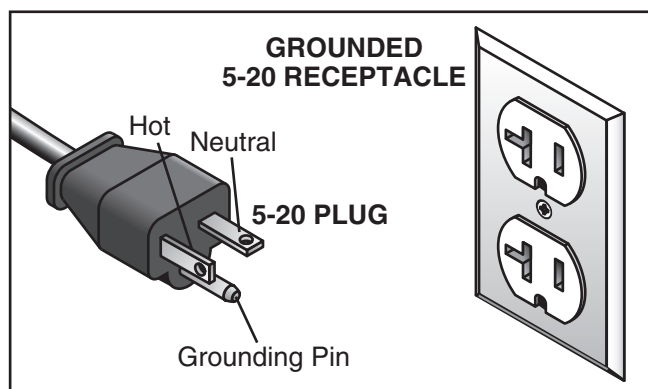

**Figure 2.** Typical 5-20 plug and receptacle.

## **!WARNING**

**Serious injury could occur if you connect machine to power before completing setup process. DO NOT connect to power until instructed later in this manual.**

Improper connection of the equipment-grounding wire can result in a risk of electric shock. The wire with green insulation (with or without yellow stripes) is the equipment-grounding wire. If repair or replacement of the power cord or plug is necessary, do not connect the equipment-grounding wire to a live (current carrying) terminal.

Check with a qualified electrician or service personnel if you do not understand these grounding requirements, or if you are in doubt about whether the tool is properly grounded. If you ever notice that a cord or plug is damaged or worn, disconnect it from power, and immediately replace it with a new one.



## Extension Cords

We do not recommend using an extension cord with this machine. If you must use an extension cord, only use it if absolutely necessary and only on a temporary basis.

Extension cords cause voltage drop, which can damage electrical components and shorten motor life. Voltage drop increases as the extension cord size gets longer and the gauge size gets smaller (higher gauge numbers indicate smaller sizes).

Any extension cord used with this machine must be in good condition and contain a ground wire and matching plug/receptacle. Additionally, it must meet the following size requirements:

**Minimum Gauge Size at 110V ..... 12 AWG**  
**Minimum Gauge Size at 220V ..... 14 AWG**  
**Maximum Length (Shorter is Better)..... 50 ft.**

## Voltage Conversion

The voltage conversion **MUST** be performed by a qualified electrician. To perform the voltage conversion, replace the power cord, install the correct plug, and rewire the motor to the new voltage, according to the provided wiring diagram on **Page 52**.

**Note:** *If the diagram included on the motor conflicts with the one in this manual, the motor may have changed since the manual was printed. Use the diagram provided inside the motor wiring junction box.*

### To convert the machine to 110V:

1. DISCONNECT MACHINE FROM POWER!
2. Replace the power cord with one that matches the cord specifications under **Circuit Recommendations for 110V** on **Page 9**.
3. Replace the 6-15 plug on the power cord with a NEMA 5-20 plug.
4. Re-wire the motor as illustrated in the wiring diagram.

# Disabling & Locking Switch

The ON/OFF switch can be disabled and locked by inserting a padlock through the ON button, as shown. Locking the switch in this manner can prevent unauthorized operation of the machine, which is especially important if the machine is not stored inside an access-restricted building.

**IMPORTANT:** Locking the switch with a padlock only restricts its function. It is not a substitute for disconnecting power from the machine when adjusting or servicing.

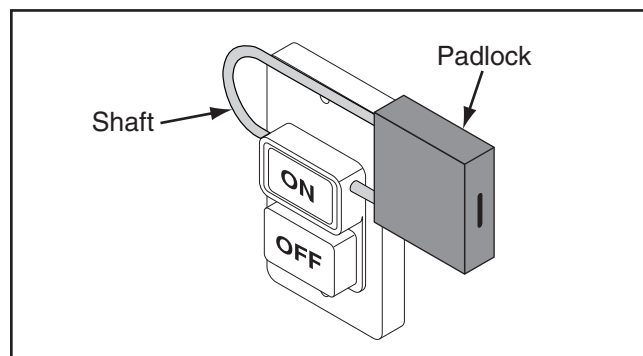

Figure 3. Switch disabled by a padlock.

## ⚠ WARNING

Children or untrained people can be seriously injured by this machine. This risk increases with unsupervised operation. To help prevent unsupervised operation, disable and lock the switch before leaving machine unattended! Place key in a well-hidden or secure location.

## NOTICE

The padlock shaft diameter is important to the disabling function of the switch. With any padlock used to lock the switch, test the switch after installation to ensure that it is properly disabled.

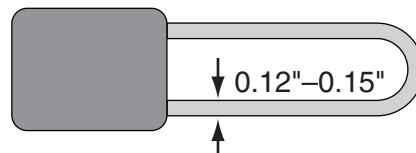

# SECTION 3: SETUP

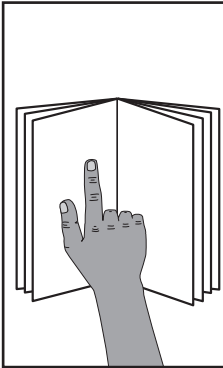

## **!WARNING**

This machine presents serious injury hazards to untrained users. Read through this entire manual to become familiar with the controls and operations before starting the machine!

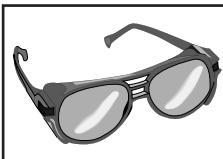

## **!WARNING**

Wear safety glasses during the entire setup process!

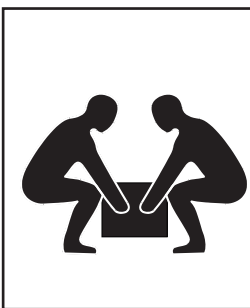

## **!WARNING**

This machine and its components are very heavy. Get lifting help or use power lifting equipment such as a forklift to move heavy items.

## Needed for Setup

The following are needed to complete the setup process, but are not included with your machine:

Description	Qty
• Safety Glasses (for each person).....	1
• Assistant.....	1
• Cleaner/Degreaser .....	As Needed
• Disposable Shop Rags.....	As Needed
• Wrenches or Sockets 13mm .....	2
• Wrench or Socket 10mm.....	1
• Wrench 14mm .....	1
• Hex Wrench 4, 5 mm .....	1 Ea.
• Phillips Screwdriver .....	1
• Machinist's Square .....	1
• Ruler.....	1
• Straightedge .....	1
• Feeler Gauge 0.016" .....	1
• Dust Collector.....	1
• Dust Hoses.....	1

## Unpacking

This machine was carefully packaged for safe transport. When unpacking, separate all enclosed items from packaging materials and inspect them for shipping damage. ***If items are damaged, please call us immediately at (570) 546-9663.***

**IMPORTANT:** Save all packaging materials until you are completely satisfied with the machine and have resolved any issues between Grizzly or the shipping agent. *You MUST have the original packaging to file a freight claim. It is also extremely helpful if you need to return your machine later.*



# Hardware Recognition Chart

USE THIS CHART TO MATCH UP HARDWARE DURING THE ASSEMBLY PROCESS.

MEASURE BOLT DIAMETER BY PLACING INSIDE CIRCLE

- #10
- 1/4"
- 5/16"
- 3/8"
- 7/16"
- 1/2"

- 4mm
- 5mm
- 6mm
- 8mm
- 10mm
- 12mm
- 16mm

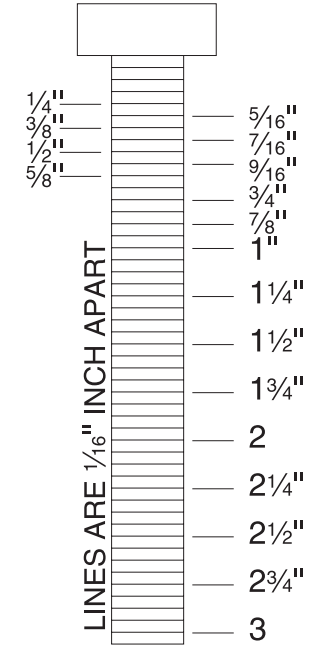
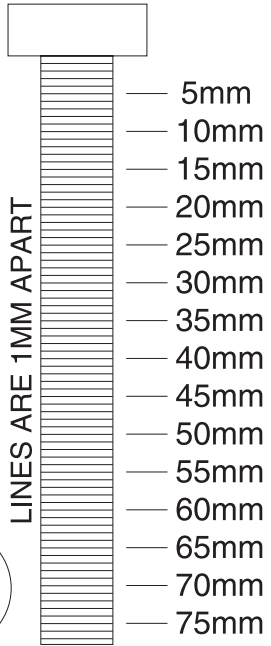
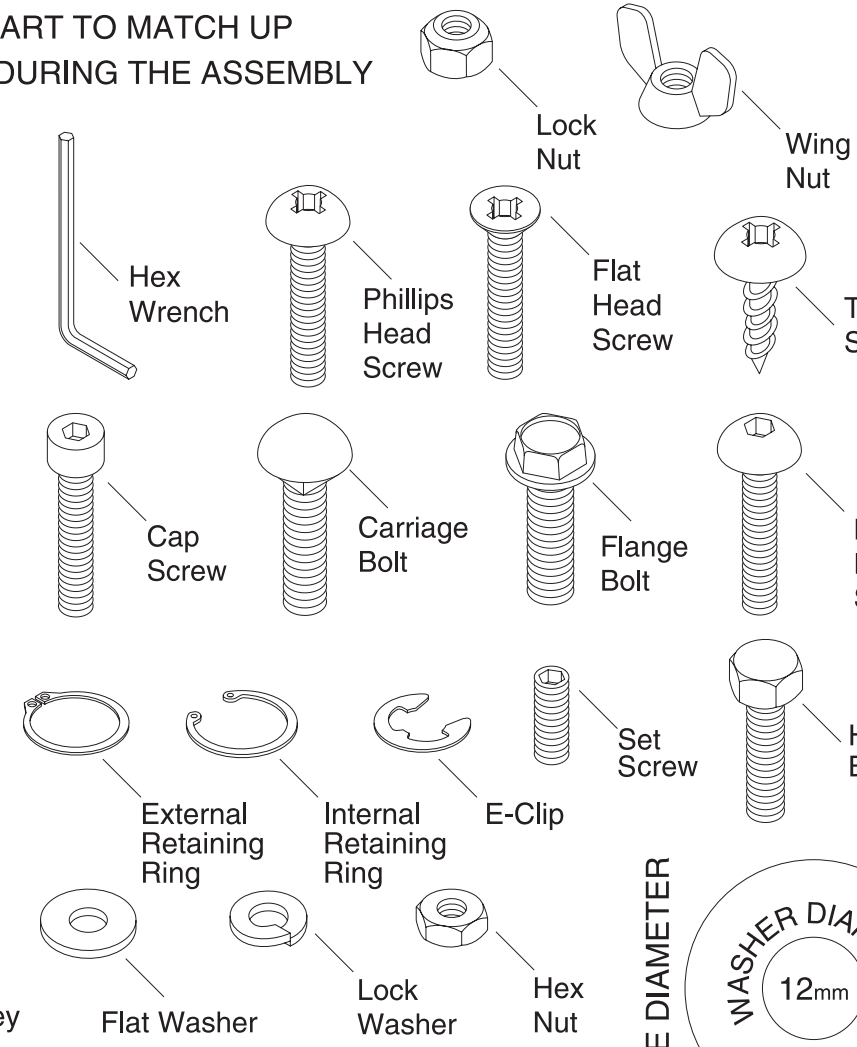

WASHERS ARE MEASURED BY THE INSIDE DIAMETER

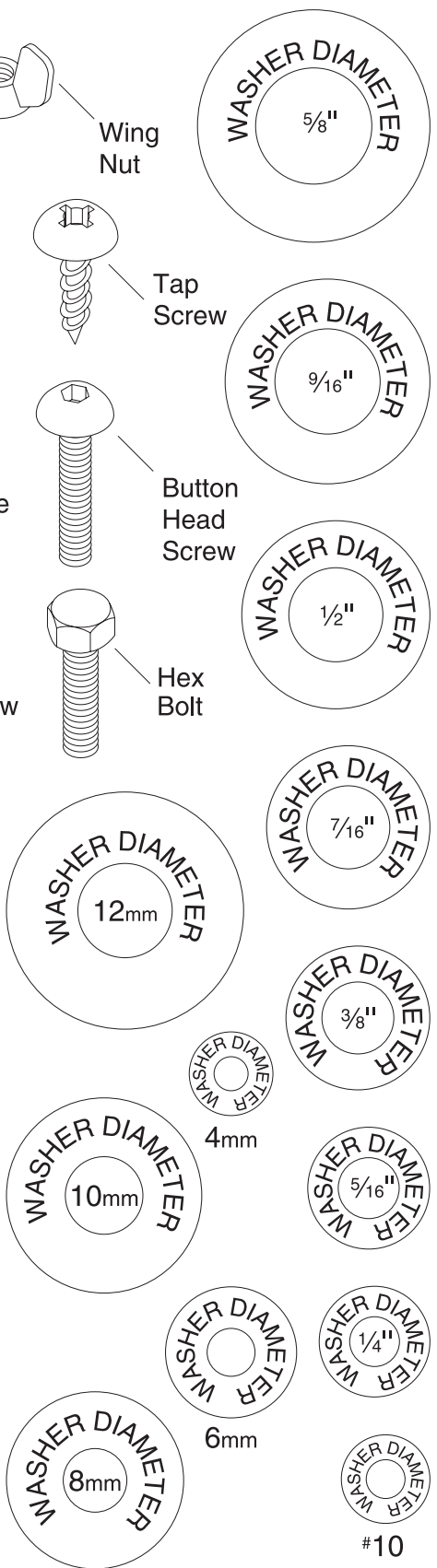

# Inventory

The following is a list of items shipped with your machine. Before beginning setup, lay these items out and inventory them.

If any non-proprietary parts are missing (e.g. a nut or a washer), we will gladly replace them; or for the sake of expediency, replacements can be obtained at your local hardware store.

Contents (Figures 4–5)	Qty
A. Bandsaw Unit .....	1
B. Cabinet Stand.....	1
C. Feet $\frac{3}{8}$ -16 (Stand) .....	4
D. Motor .....	1
E. Guide Post Adjustment Knob .....	1
F. Blade Tension Quick Release Lever .....	1
G. Table.....	1
H. Trunnion Hand Knobs M10-1.5 (Table).....	2
I. Miter Gauge.....	1
J. Fence Assembly.....	1
K. Resaw Fence .....	1
L. Front Rail .....	1
M. Rear Rail .....	1
N. Moving Plate (Fence).....	1
O. Resaw Lock Handle w/Nut (Fence).....	1
P. Fence Lock Lever (Fence).....	1

## Hardware (Not shown)

- Cap Screws M8-1.25 x 20 (Motor)..... 2
- Lock Washers 8mm (Motor) .....
- Fender Washers 8mm (Motor) .....
- Flat Washers 6mm (Front Rail) .....
- Lock Washers 6mm (Front Rail).....
- Hex Bolts M6-1 x 20 (Front Rail).....
- Cap Screws M6-1 x 16 (Rear Rail).....
- Hex Bolt M8-1.25 x 80 (Positive Stop).....
- Hex Nut M8-1.25 (Positive Stop) .....
- Carriage Bolts M8-1.25 x 20 (Stand).....
- Flange Nuts M8-1.25 (Stand) .....
- Hex Nut M8-1.25 (Quick Release Lever)....
- Hex Nut M8-1.25 (Fence Lock Lever).....
- Flat Washer 8mm (Resaw Lock Handle)....
- Hex Nuts  $\frac{3}{8}$ -16 (Feet).....
- Flat Washers 10mm (Feet) .....
- Hex Wrench 6mm.....
- Flange Screw M6-1 x 8 (Guide Post Knob )1

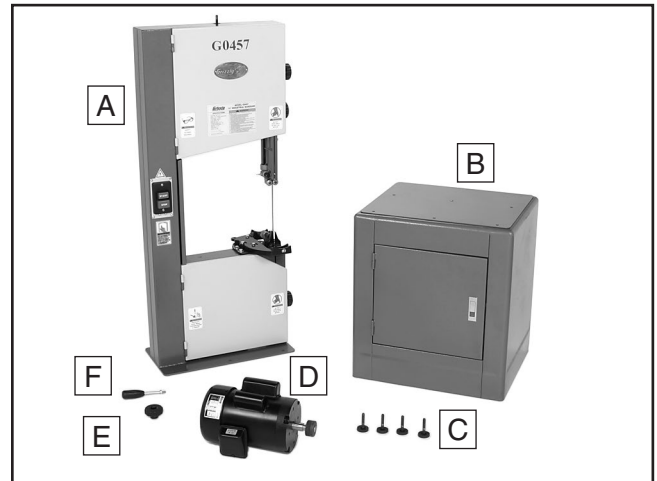

Figure 4. Bandsaw, stand, motor, and components

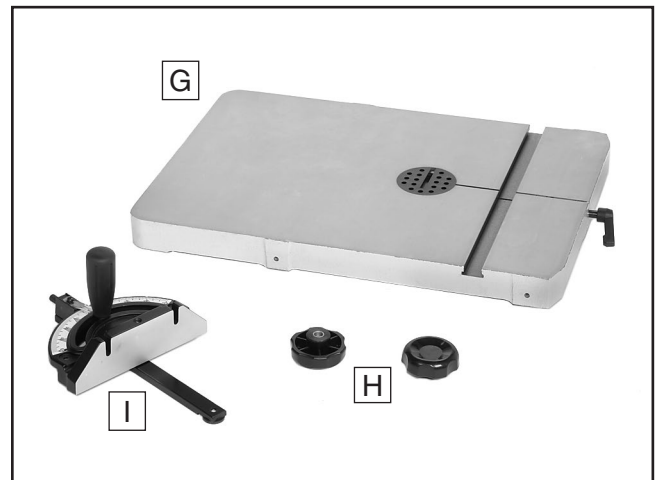

Figure 5. Table, miter gauge, and hardware bags.

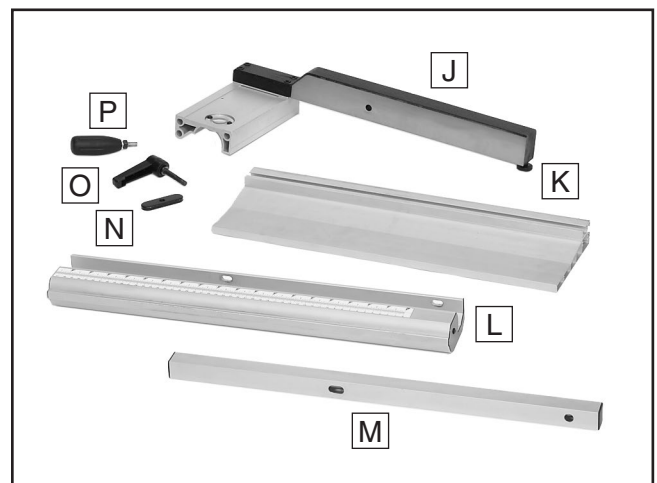



Figure 6. Main fence components.



# Clean Up

The unpainted surfaces are coated with a waxy oil to prevent corrosion during shipment. Remove this protective coating with a solvent cleaner or degreaser. For thorough cleaning, some parts must be removed. **For optimum performance, clean all moving parts or sliding contact surfaces.** Avoid chlorine-based solvents, such as acetone or brake parts cleaner that may damage painted surfaces. Always follow the manufacturer's instructions when using any type of cleaning product.

	<p><b>! WARNING</b> Gasoline and petroleum products have low flash points and can explode or cause fire if used to clean machinery. <b>DO NOT</b> use these products to clean the machinery.</p>
---	--

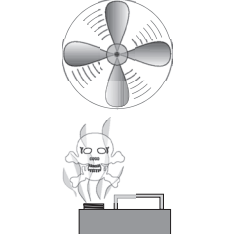
	<p><b>! CAUTION</b> Many cleaning solvents are toxic if inhaled. Minimize your risk by only using these products in a well ventilated area.</p>
---	---

# Site Considerations

## Floor Load

Refer to the **Machine Data Sheet** for the weight and footprint specifications of your machine. Some residential floors may require additional reinforcement to support both the machine and operator.

## Placement Location

Consider existing and anticipated needs, size of material to be processed through each machine, and space for auxiliary stands, work tables or other machinery when establishing a location for your new machine. See **Figure 7** for the minimum working clearances.

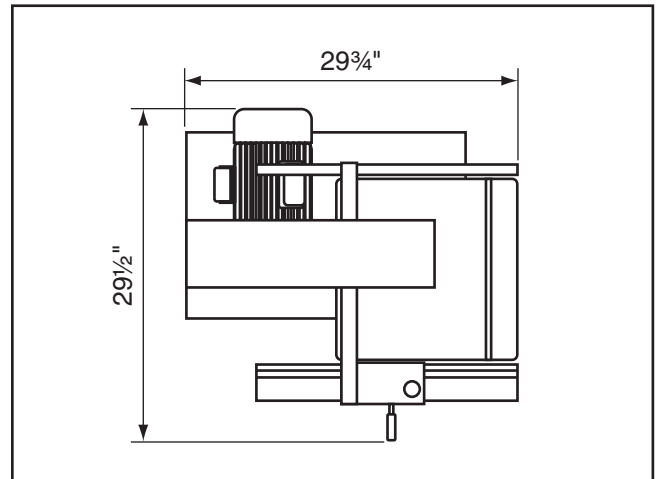
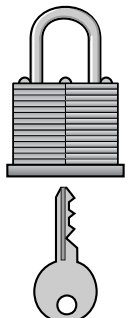

Figure 7. Working clearances.

	<p><b>! CAUTION</b> Children and visitors may be seriously injured if unsupervised around this machine. Lock entrances to the shop or disable start switch or power connection to prevent unsupervised use.</p>
--	---



# Assembly

The machine must be fully assembled before it can be operated. Before beginning the assembly process, refer to **Needed for Setup** and gather all listed items. To ensure the assembly process goes smoothly, first clean any parts that are covered or coated in heavy-duty rust preventative (if applicable).

## To assemble the bandsaw:

1. Turn the cabinet stand upside down and install the feet, as shown in **Figure 8**.



**Figure 8.** Installing feet on cabinet.

2. Set the cabinet upright, move it to its final position, then adjust the feet so the cabinet is level side-to-side and front-to-back.
3. Secure the position of the feet by tightening the hex nut/washers against the stand.



## **!WARNING**

The bandsaw body is heavy. **DO NOT** over-exert yourself while unpacking or moving your machine—get assistance from another person.

4. With the help of an assistant, set the bandsaw unit onto the stand, align the mounting holes, then open the door on the cabinet stand.
5. Have your assistant hold the bandsaw while you secure the body to the stand with the carriage bolts and flange nuts (**Figure 9**).



**Figure 9.** Securing the body to the stand.

6. Secure the guide post adjustment knob with (1) M6-1 x 8 flange screw (see **Figure 10**).

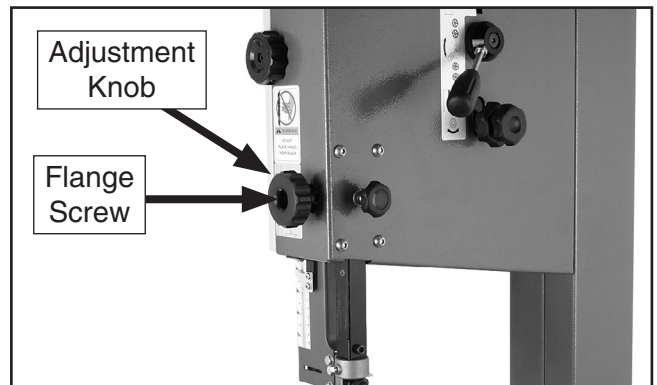

**Figure 10.** Guide post adjustment knob installed.



7. Thread an M8-1.25 hex nut all the way onto the quick release lever, as shown in **Figure 11**, then thread the lever into the quick release hub and tighten the hex nut against the hub to lock the lever in place.

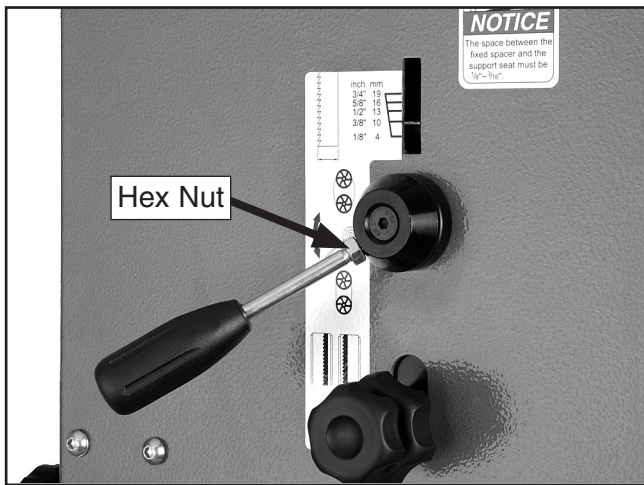

**Figure 11.** Quick release lever installed.

8. Have an assistant hold the motor in position against the backside of the frame, as shown in **Figure 12**.



**Figure 12.** Installing motor (outside view).

9. From the inside of the bandsaw, loosely fasten the motor to the body with the cap screws, lock washers, and flat washers, as shown in **Figure 13**.

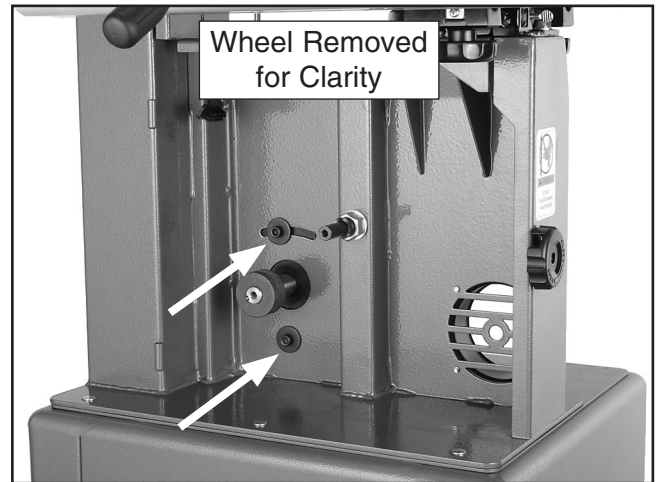

**Figure 13.** Installing motor (inside view).

10. Place the belt on the pulleys and pivot the motor so the belt is tight, then tighten the cap screws. Refer to **Tensioning V-Belt** on **Page 45** to properly tension the drive belt.
11. Refer to **Wiring** on **Page 51** and wire the motor to the switch cord.
12. Remove the blade from the top and bottom wheels, then remove the table pin and table insert from the table.
13. Place the table bolts through the trunnions.
14. Thread the table trunnion hand knobs onto the table bolts to secure the table (see **Figure 14**).

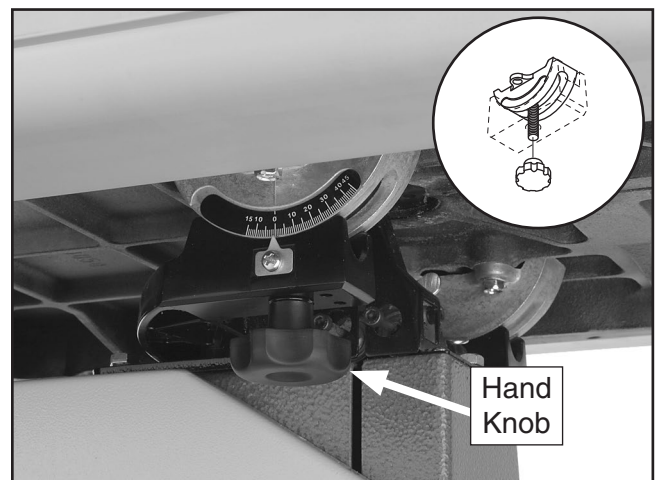

**Figure 14.** Table installed on trunnions.



15. Replace the blade, and for now, only put enough tension on it to keep it on the wheels.
16. Re-install the table pin and table insert.
17. Fasten the rear rail to the back of the table with two M6-1 x 16 cap screws, as shown in **Figure 15**.



**Figure 15.** Rear rail installed.

18. Attach the front rail to the front of the bandsaw table with the two M6-1 x 20 hex bolts, 6mm lock washers and flat washers, as shown in **Figure 16**.

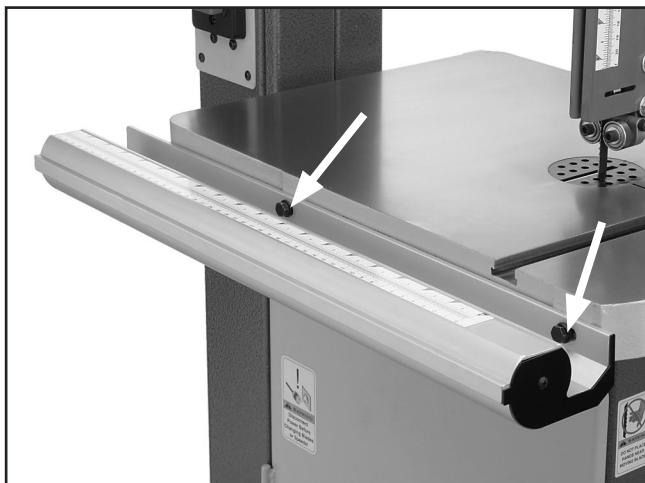

**Figure 16.** Installed front rail.

19. Thread an M8-1.25 hex nut all the way onto the fence lock lever shown in **Figure 17**, then thread the lever handle into fence pivot block and tighten the hex nut against the pivot block to secure the handle.

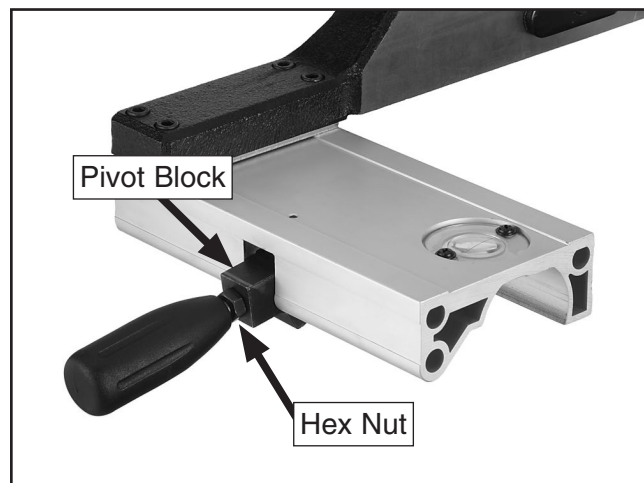

**Figure 17.** Fence lock lever installed on fence assembly.

20. Place an 8mm flat washer on the resaw lock handle and slide it through the hole in the fence.
21. Thread the moving plate onto the end of the locking adjustment handle threads.
22. Slide the resaw fence over the moving plate, as shown in **Figure 18**, so the moving plate fits inside the channel of the resaw fence.

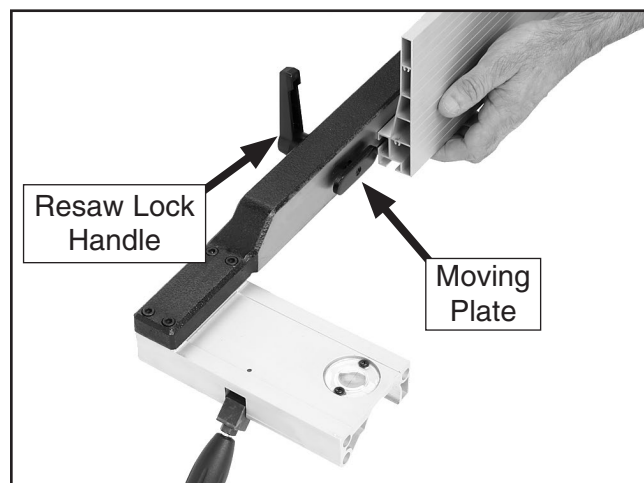

**Figure 18.** Attaching resaw fence to standard fence.



23. Pull the handle up and place the fence assembly on the fixed rail, as shown in **Figure 19**.



**Figure 19.** Correctly installed fence.

24. Push the handle down to lock the fence assembly in place.
25. Position the resaw fence evenly on the table and use the locking adjustment handle to lock it in place.
26. Thread the M8-1.25 hex nut halfway onto the M8-1.25 x 80 hex bolt (this is the positive stop bolt).
27. Thread the positive stop bolt into the threaded hole on bandsaw body as shown in **Figure 20**.

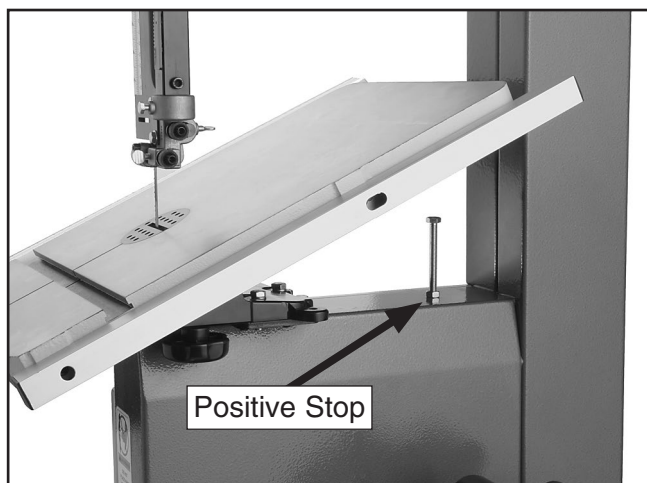

**Figure 20.** Installed positive stop bolt.

## Dust Collection

### **⚠ CAUTION**

**DO NOT** operate the Model G0457 without an adequate dust collection system. This saw creates substantial amounts of wood dust while operating. Failure to use a dust collection system can result in short and long-term respiratory illness.

#### **Recommended CFM at Dust Port: 400 CFM**

*Do not confuse this CFM recommendation with the rating of the dust collector. To determine the CFM at the dust port, you must consider these variables: (1) CFM rating of the dust collector, (2) hose type and length between the dust collector and the machine, (3) number of branches or wyes, and (4) amount of other open lines throughout the system. Explaining how to calculate these variables is beyond the scope of this manual. Consult an expert or purchase a good dust collection "how-to" book.*

#### **To connect a dust collection hose:**

1. Fit the 4" dust hose over the dust port, as shown in **Figure 21**, and secure in place with a hose clamp.
2. Tug the hose to make sure it does not come off.

**Note:** A tight fit is necessary for proper performance.



**Figure 21.** Dust hose attached to dust port.



# Blade Tracking

The blade tracking is primarily affected by the tilt of the upper wheel, also known as "Center Tracking"; and the alignment of both wheels, also known as "Coplanar Tracking." (For Coplanar Tracking, see the **Wheel Alignment** instructions on **Page 49**.)

The wheels on the Model G0457 were aligned at the factory, so Center Tracking is the only adjustment that needs to be performed when the saw is new.

## To center track the blade:

1. DISCONNECT BANDSAW FROM POWER!
2. Adjust the upper and lower guide bearings and support bearings as far away as possible from the blade.
3. Open the upper wheel cover.
4. Adjust blade tension until the mark on the blade tension scale matches the size of the installed blade.

## CAUTION

The cast iron spokes may have sharp edges and the blade teeth may extend beyond the edge of the wheel, creating a laceration hazard. Be careful when turning the wheels by hand.

5. Spin the upper wheel by hand at least three times and watch how the blade rides on the crown of the wheel. Refer to **Figure 22** for an illustration of this concept.

—If the blade rides in the center of the upper wheel and is centered on the peak of the wheel crown, then the bandsaw is already tracked properly and no further adjustments are needed at this time.

—If the blade does not ride in the center of the upper wheel and is not centered on the peak of the wheel crown, then continue with the following steps.

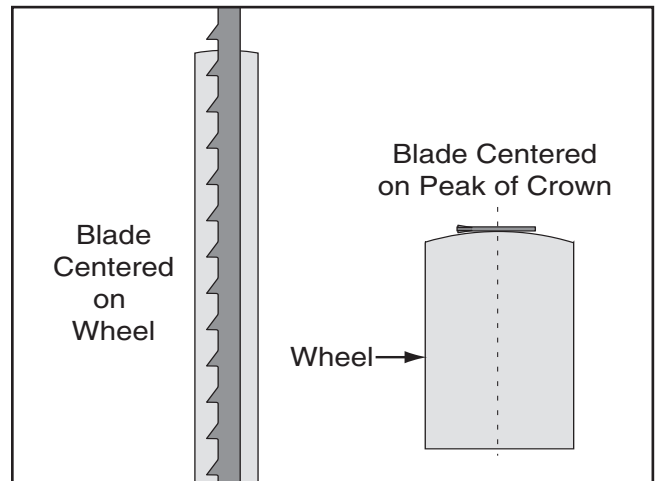

**Figure 22.** Center tracking profiles.

6. Loosen the tracking control lock knob (**Figure 23**) so that the tracking control knob will rotate for adjustments.

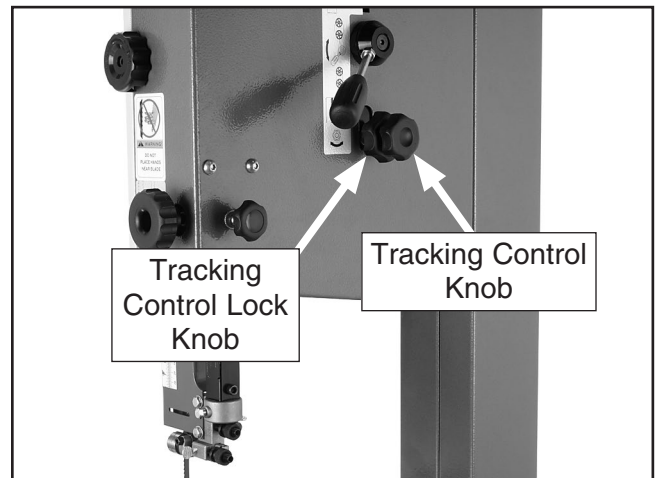

**Figure 23.** Location of tracking control knob.

7. Spin the upper wheel with one hand and rotate the tracking control knob with the other hand to make the blade ride in the center of the bandsaw wheel tire.
8. Tighten the tracking control lock knob and close the upper wheel cover.

*For the best performance from your saw, regularly maintain the proper tracking of the blade.*

## **NOTICE**

Changes in the blade tension may change the blade tracking.



# Test Run

Once assembly is complete, test run the machine to ensure it is properly connected to power and safety components are functioning correctly.

If you find an unusual problem during the test run, immediately stop the machine, disconnect it from power, and fix the problem **BEFORE** operating the machine again. The **Troubleshooting** table in the **SERVICE** section of this manual can help.

## **!WARNING**

**Serious injury or death can result from using this machine BEFORE understanding its controls and related safety information. DO NOT operate, or allow others to operate, machine until the information is understood.**

## **!WARNING**

**DO NOT start machine until all preceding setup instructions have been performed. Operating an improperly set up machine may result in malfunction or unexpected results that can lead to serious injury, death, or machine/property damage.**

### To test run machine:

1. Clear all setup tools away from machine.
2. Connect machine to power supply.
3. Turn the machine **ON**.
4. Listen and watch for abnormal noises or actions. The machine should run smoothly with little or no vibration or rubbing noises.

—Strange or unusual noises must be investigated and corrected before operating the machine further. Always disconnect the machine from power when investigating or correcting potential problems.

5. Turn the machine **OFF**.

# Table Stop Calibration

The adjustable positive stop allows the table to be reset 90° to the blade after tilting to the right.

### To set the positive stop:

1. **DISCONNECT BANDSAW FROM POWER!**
2. Adjust blade tension until the mark on the blade tension scale matches the size of the installed blade.
3. Loosen the hex nut that locks the positive stop bolt in place and loosen the table tilt hand knobs.
4. Raise the guide post and place a machinist's square on the table next to the side of the blade, as illustrated in **Figure 24**. Adjust the table square with the blade, then secure with the table tilt knobs.

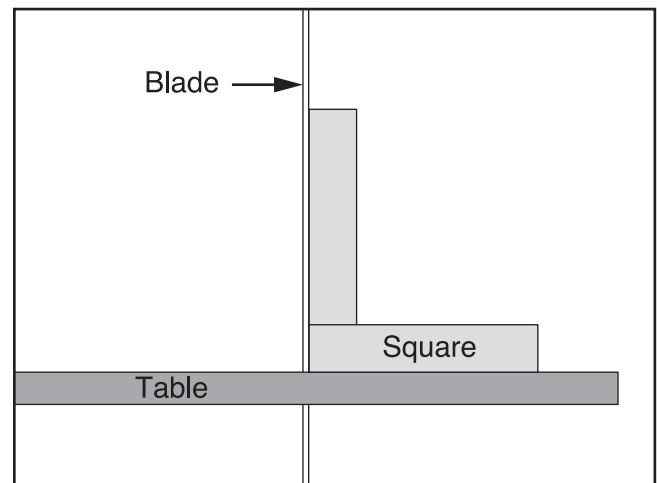

**Figure 24.** Squaring table to blade.

5. Adjust the positive stop bolt to the table.
6. Secure the positive stop bolt by tightening the hex nut against the trunnion bracket.
7. Check the adjustment for accuracy once you have tightened the hex nut.



# Table Tilt Calibration

The pointer on the table tilt scale must be calibrated in order for the scale reading to be accurate.

## To calibrate the pointer on the table tilt scale:

1. Make sure that the blade is tensioned and is tracking correctly, and that the table is 90° to the blade (see **Table Stop Calibration** on **Page** .
2. Loosen the screw on the pointer (**Figure 25**), but do not remove it.

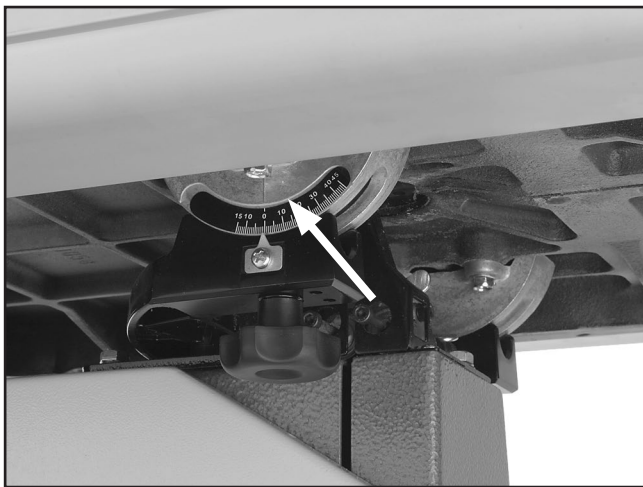

**Figure 25.** Table tilt scale.

3. Align the tip of the pointer with the 0° mark on the table tilt scale.
4. Tighten the screw on the pointer so that the pointer is locked in place.

# Table Alignment

To ensure cutting accuracy when the table is first installed, the table should be aligned so that the miter slot is parallel to the bandsaw blade. This procedure works best with a 3/4" blade installed.

## To align the table so the miter slot is parallel to the bandsaw blade:

1. Make sure that the blade is tracking properly and that it is correctly tensioned.
2. DISCONNECT BANDSAW FROM POWER!
3. Loosen the trunnion bolts that secure the trunnions to the table.
4. Place an accurate straightedge along the blade. The straightedge should lightly touch both the front and back of the blade.

**Note:** Make sure the straightedge does not go across a tooth.

5. Use a fine ruler to gauge the distance between the straightedge and the miter slot. The distance you measure should be the same at both the front and the back of the table (see **Figure 26**).
6. Adjust the table as needed for proper alignment.
7. Tighten the trunnion bolts.

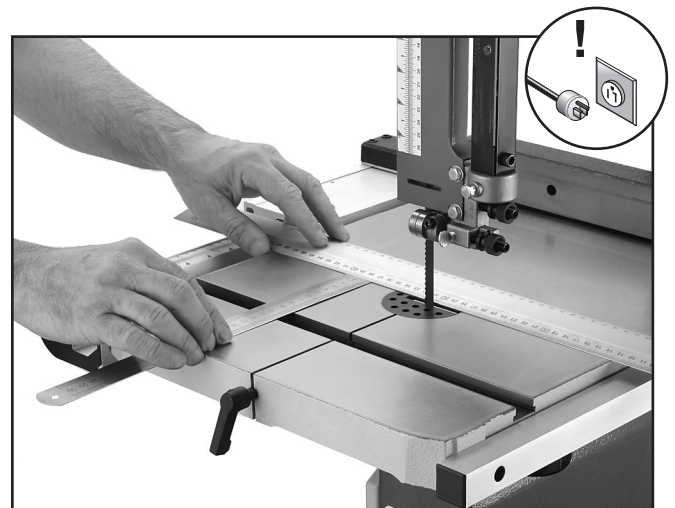

**Figure 26.** Measuring miter slot parallelism with the blade.



# Fence Alignment

To ensure cutting accuracy when the fence is first installed, the fence should be aligned with the miter slot.

## To align the fence parallel with the miter slot:

1. If the fence is mounted on the left-hand side of the blade, remove it and remount it next to the miter slot.
2. Loosen the four cap screws located on the top face of the fence (**Figure 27**).



**Figure 27.** Four fence cap screws.

3. Adjust the fence face parallel with the edge of the miter slot.
4. Tighten the four cap screws, being careful not to move the fence.

# Miter Gauge

The miter gauge needs to be calibrated to the blade when it is first mounted in the miter slot.

## To calibrate the miter gauge:

1. Place one edge of a machinist's square against the face of the miter gauge and the other side against the blade face, as shown in **Figure 28**.

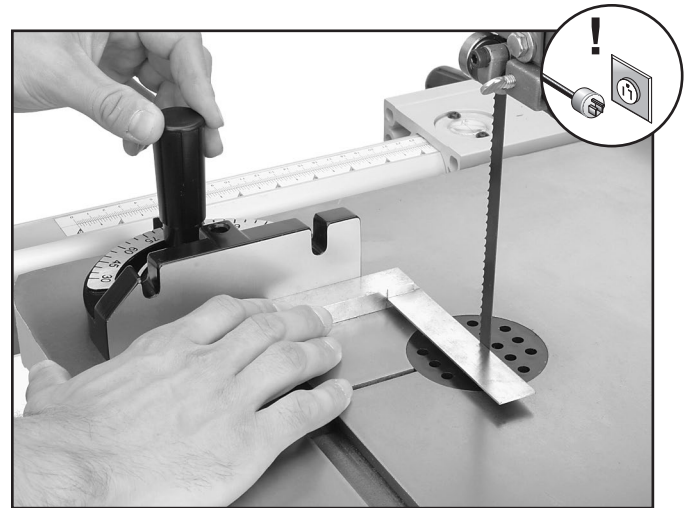

**Figure 28.** Squaring miter gauge to blade.

2. Loosen the lock knob on the miter gauge and adjust it flush with the edge of the square.
3. Tighten the lock knob, and verify the setting.

**Note:** Sometimes the tightening procedure can affect the adjustment.

4. Loosen the screw that secures the angle pointer and adjust the pointer to the 0° mark on the scale.
5. Retighten the screw that secures the angle pointer.



# Blade Tensioning

A properly tensioned blade is essential for making accurate cuts and is a prerequisite for making many bandsaw adjustments. The blade tension scale shows the approximate tension, but the steps below will allow you to get the optimum tension for the installed blade.

## To tension the bandsaw blade:

1. Make sure you have completed the **Test Run** procedure on **Page 21** and that the blade is tracking properly.
2. Raise the upper blade guide assembly as high as it will go, and adjust the upper and lower guide blocks as far away from the blade as possible.

**Note:** *This procedure will NOT work if the guide blocks have any contact with the blade.*

3. Adjust blade tension until the mark on the blade tension scale matches the size of the installed blade.

**Note:** *This scale can only be considered a general guide. Complete the following steps to accurately set blade tension.*

4. Turn the bandsaw **ON**.
5. Slowly release the tension one quarter of a turn at a time. When you see the bandsaw blade start to flutter, stop decreasing the tension.
6. Now, slowly increase the tension until the blade stops fluttering, then tighten the tension another quarter turn.
7. Look at what the tension gauge reads and use that as a guide for tensioning that blade in the future.

**Note:** *Always de-tension the blade after use to increase blade life and reduce strain on the bandsaw components.*

## NOTICE

After blade tension and tracking are set correctly, you **MUST** properly adjust the upper and lower support bearings and guide-block assemblies into position before cutting.

## Adjusting Support Bearings

The support bearings are positioned behind the blade for support during cutting operations. Proper adjustment of the support bearings is an important part of making accurate cuts and also keeps the blade teeth from coming in contact with the guide bearings while cutting.

## To adjust the support bearings:

1. Make sure that the blade is tracking properly and that it is correctly tensioned.
2. **DISCONNECT BANDSAW FROM POWER!**
3. Familiarize yourself with the support bearing controls shown in **Figure 29**.

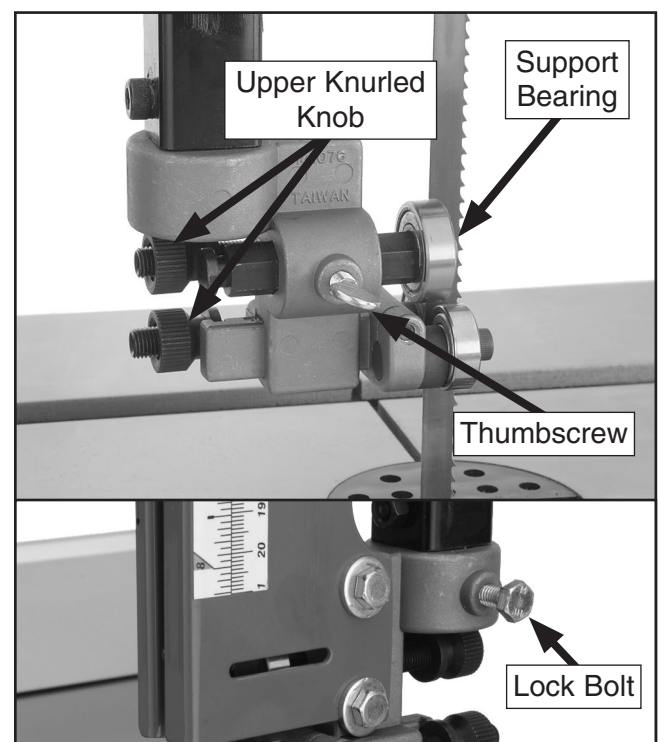
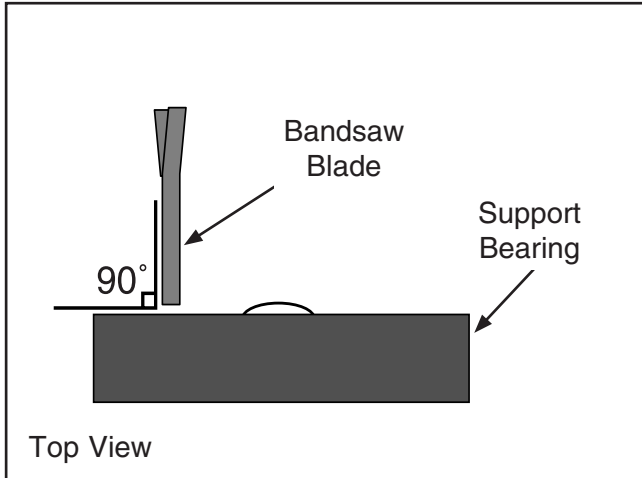

Figure 29. Support bearing controls.



4. Loosen the assembly lock bolt.
5. Rotate the blade guide assembly side-to-side, until the blade is perpendicular to the face of the support bearing as illustrated in **Figure 30**.



**Figure 30.** Blade should be perpendicular (90°) to the face of the support bearing.

6. Tighten the assembly lock bolt.
7. Loosen the thumbscrew on the support bearing adjustment shaft.
8. Place a 0.016" feeler gauge between the support bearing and the blade, and use the upper knurled knob to position the bearing 0.016" away from the back of the blade, as illustrated in **Figure 31**.

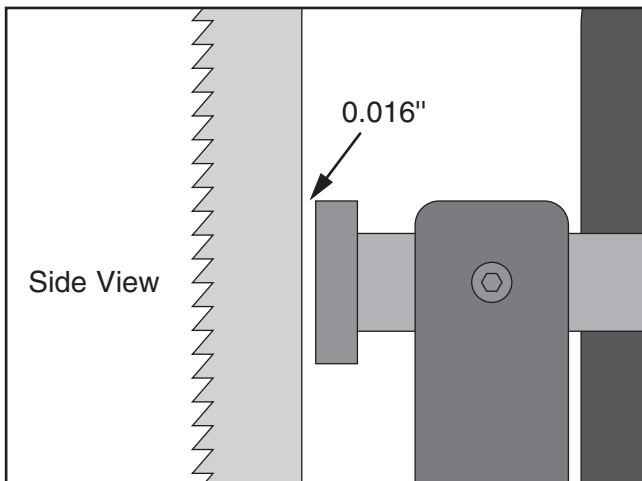

**Figure 31.** Blade should be aligned approximately 0.016" away from the bearing edge.

**Note:** For a quick gauge, fold a dollar bill in half twice (four thicknesses of a dollar bill is approximately 0.016") and place it between the support bearing and the blade as shown in **Figure 32**.

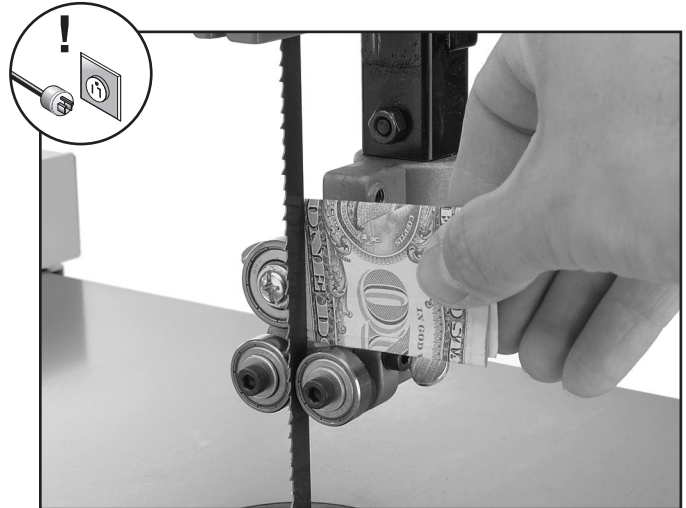

**Figure 32.** Dollar bill folded twice to make an approximate 0.016" gauge.

9. Tighten the thumbscrew to keep the support bearing locked in place.
10. Repeat **Steps 4–9** for the lower support bearings.

## **NOTICE**

**Whenever changing a blade or adjusting tension and tracking, the upper and lower blade support bearings and blade guide bearings must be properly adjusted before cutting operations.**



# Blade Guide Adjustments

The blade guides consist of an upper and lower set of ball bearings that provide side-to-side support to help keep the blade straight while cutting. The blade guides are designed to be adjusted in two ways—forward/backward and side-to-side.

## To adjust the upper and lower blade guides:

1. Make sure that the blade is tracking properly and that it is correctly tensioned.
2. DISCONNECT BANDSAW FROM POWER!
3. Familiarize yourself with the blade guide controls shown in **Figure 33**.

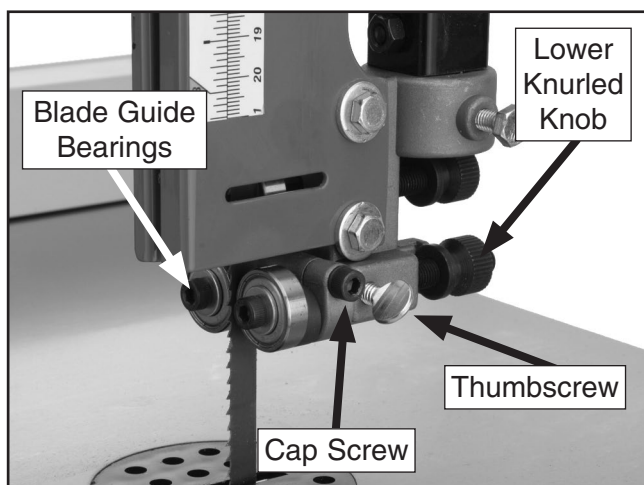

**Figure 33.** Blade guide controls.

4. Loosen the thumbscrew on the lateral adjustment rod.
5. Rotate the lower knurled knob to position the blade guides so the edges of the bearings are 0.016" behind the blade gullets, as illustrated in **Figure 34**.

**Note:** The 0.016" spacing is ideal, although with larger blades it may not be possible. In such cases, adjust the guide bearings as far forward as possible to the blade gullets, and still maintain the proper support bearing spacing adjustment.

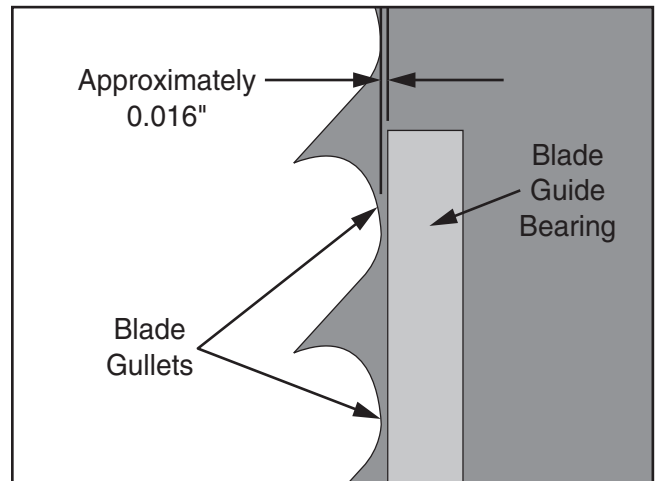

**Figure 34.** Lateral adjustment of blade guides.

## NOTICE

Make sure that the blade teeth will not contact the guide bearings when the blade is against the rear support bearing during the cut or the blade teeth will be ruined.

6. Tighten the thumbscrew on the lateral adjustment rod.
  7. Loosen the cap screws.
  8. With the 4mm hex wrench, rotate the center portion of the blade guide bearings to laterally position the bearings 0.004" away from the blade.
- Note:** 0.004" is approximately the thickness of a piece of paper.
9. Tighten the cap screw to lock the blade guide bearings in position.
  10. Repeat **Steps 4–9** for the lower guides.

## NOTICE

Whenever changing a blade or adjusting tension and tracking, the upper and lower blade support bearings and guide bearings must be properly adjusted before cutting operations.



# SECTION 4: OPERATIONS

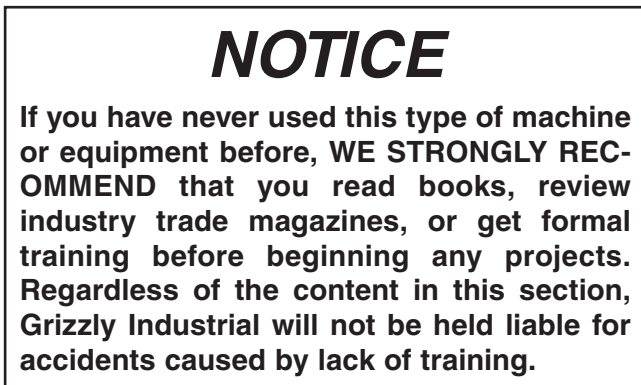
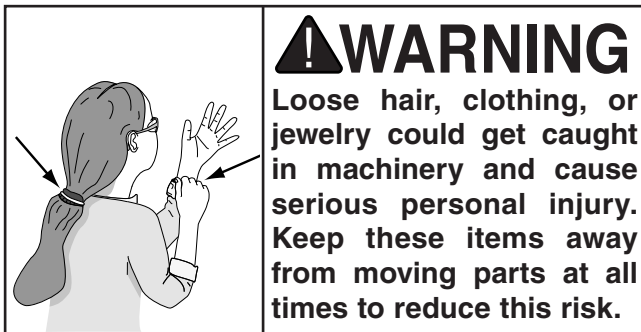
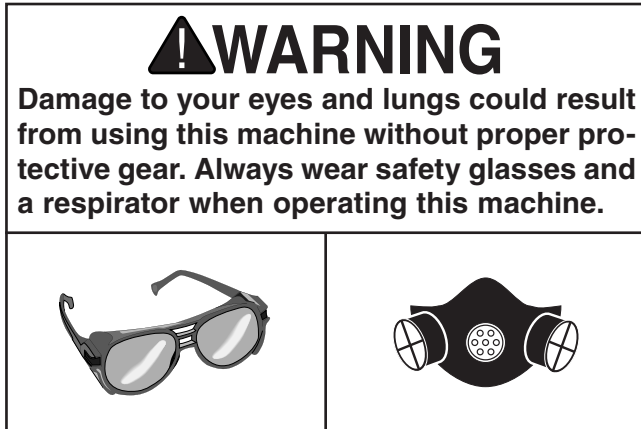

## Basic Controls

Use the descriptions and figures below to become familiar with the basic controls of your machine.

**Blade Tension Knob:** Adjusts the tension on the blade.

**Blade Tension Quick Release Lever:** Quickly tensions or releases the blade without losing its setting.

**Blade tracking Adjustment Knob:** Adjusts the blade tracking.

**Guide Post Adjustment Knob:** Raises and lowers the blade guide post.

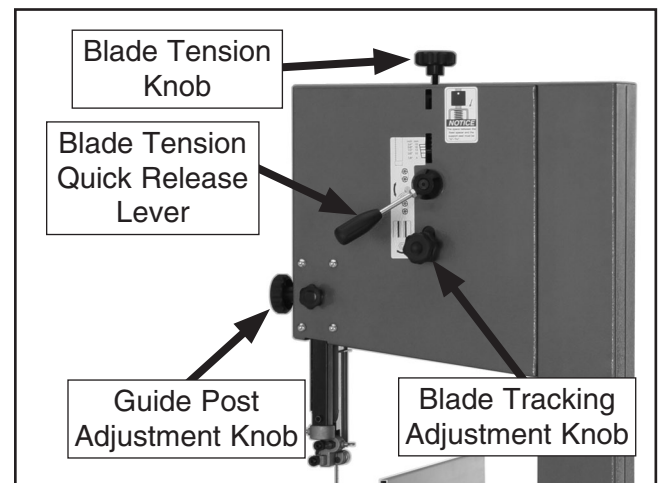

Figure 35. Basic controls (rear).



**ON/OFF Switch:** Starts and stops the blade motor.

**Miter Gauge Lock Handle:** Locks the miter gauge at the current setting.

**Fence Lock Lever:** Locks the fence at its current position.

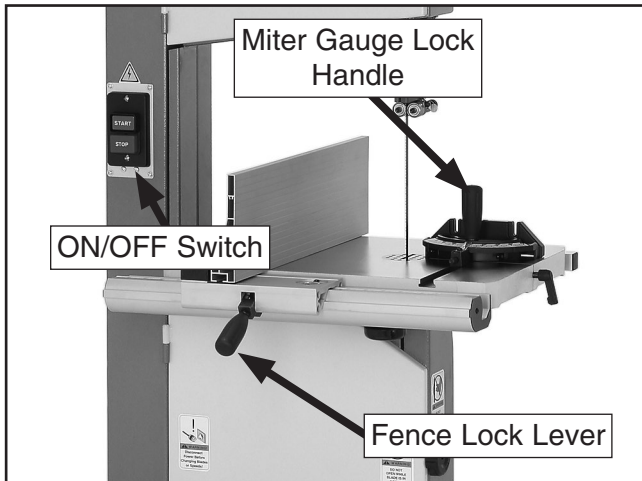

**Figure 36.** Basic controls (front).

# Overview

The bandsaw is one of the most versatile wood cutting tools in the shop. It is capable of performing many different cutting functions, including:

## Straight Cuts

- Miters
- Angles
- Compound Angles
- Resawing
- Ripping
- Crosscutting

## Irregular Cuts

- Simple and Complex Curves
- Duplicate Parts
- Circles
- Beveled Curves

A properly adjusted and tuned bandsaw can be safer to operate than most other saws and performs many functions with ease and accuracy.

## Basic Cutting Tips

**Here are some basic tips to follow when operating the bandsaw:**

- Replace, sharpen, and clean blades as necessary and make adjustments periodically to keep the saw running in top condition.
- Use light and even pressure while cutting. Light contact with the blade will permit easier line following and prevent undue friction.
- Avoid trying to turn tight corners because this will twist the blade. Remember, you must saw around corners.
- Misuse of the saw or using incorrect techniques is unsafe and results in frustration and poor cuts. Remember—the blade does the cutting with the operator's guidance.



# Workpiece Inspection

---

---

Some wood workpieces are not safe to cut or may require modification before they are safe to cut.

**Before making cuts, get in the habit of inspecting all workpieces for the following:**

- **Material Type:** This machine is intended for cutting natural and man-made wood products, laminate covered wood products, and some plastics. Cutting drywall or cementitious backer board creates extremely fine dust and may reduce the life of the bearings. This machine is NOT designed to cut metal, glass, stone, tile, etc.; cutting these materials with this saw may lead to injury.
- **Foreign Objects:** Nails, staples, dirt, rocks and other foreign objects are often embedded in wood. While cutting, these objects can become dislodged and hit the operator or break the blade, which might then fly apart. Always visually inspect your workpiece for these items. If they cannot be removed, do NOT cut the workpiece.
- **Large/Loose Knots:** Loose knots can become dislodged during the cutting operation. Large knots can cause blade damage. Choose workpieces that do not have large/loose knots or plan ahead to avoid cutting through them.
- **Wet or "Green" Stock:** Cutting wood with a moisture content over 20% causes unnecessary wear on the blade and yields poor results.
- **Excessive Warping:** Workpieces with excessive cupping, bowing, or twisting are dangerous to cut because they are unstable and can move unpredictably when being cut. DO NOT use workpieces with these characteristics!
- **Minor Warping:** Workpieces with slight cupping can be safely supported if the cupped side faces the table or fence. On the contrary, a workpiece supported on the bowed side will rock during a cut, leading to loss of control.

# Table Tilt

---

---

The bandsaw table will tilt 8° left and 45° right to provide a wide range of cutting options. Most cutting operations are done at 90° and rarely will the table need to be tilted left. Remove the positive stop bolt to tilt the table to the left.

**To tilt the table:**

1. Loosen the two table trunnion hand knobs.
2. Position the table to the desired angle of tilt. Refer to the angle gauge on the front table trunnion for the tilting angle.
3. Retighten both table trunnion hand knobs.



# Guide Post

The guide post, shown in **Figure 37**, connects the upper blade guide assembly to the bandsaw. The guide post allows the blade guide assembly to move up or down via a rack and pinion. In order to cut accurately, the blade guide assembly must be no more than 1" from the top of the workpiece at all times—this positioning provides the greatest support to the blade.

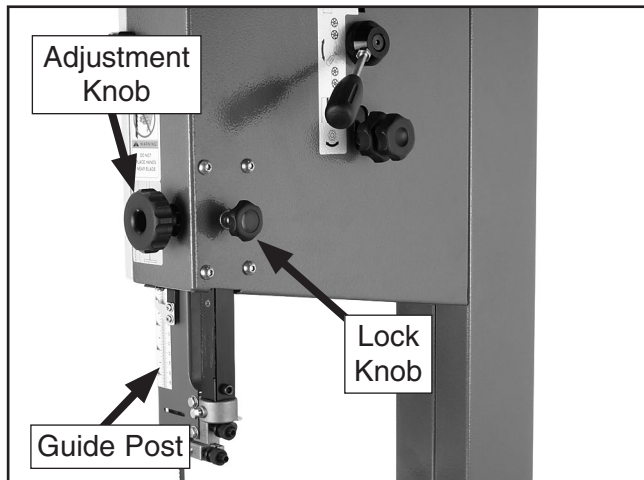

**Figure 37.** Guide post controls.

## To adjust guide post:

1. Make sure that the blade tension, blade tracking, support bearing, and blade guides are adjusted correctly.
2. Loosen the guide post lock knob shown in **Figure 37**.
3. Raise/lower the guide post with the adjustment knob to within 1" from the top of the workpiece to the bottom of the blade guide assembly.
4. Lock the guide post in place with the lock knob.

# Ripping

Ripping is the process of cutting with the grain of the wood stock. For plywood and other processed wood, ripping simply means cutting down the length of the workpiece.

## To rip with the Model G0457:

1. Adjust the fence to match the width of the cut on your workpiece and lock the fence in place.
2. Make sure the bandsaw is properly set up and adjusted as described in **SECTION 3: SETUP**.
3. Slowly feed the workpiece into the blade and continue with the cut until the blade is completely through the workpiece. **Figure 38** shows a typical ripping operation.

**Note:** *If you are cutting narrow pieces, use a push stick to protect your fingers.*



**Figure 38.** Ripping with a push stick.

## **⚠**WARNING

**NEVER** place fingers or hands in the line of cut. In the event that something unexpected happens, your hands or fingers may be pulled into the blade. **ALWAYS** use a push stick when ripping narrow pieces. Failure to follow these warnings may result in serious personal injury!



# Crosscutting

---

Crosscutting is the process of cutting across the grain of wood. For plywood and other processed wood, crosscutting simply means cutting across the width of the material.

## To crosscut with the Model G0457:

1. Mark the workpiece on the edge where you want to begin the cut.
2. Move the fence out of the way. Place the workpiece evenly against the miter gauge.
3. Line up the mark with the blade.
4. After all safety precautions have been met, turn the bandsaw **ON**. Slowly feed the workpiece into the blade and continue the cut until the blade is all the way through the workpiece. **Figure 39** shows a typical crosscutting operation.

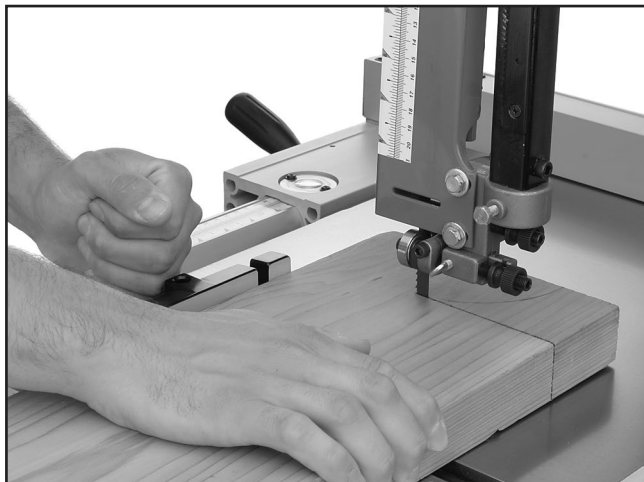

**Figure 39.** Crosscutting with miter gauge.

# Resawing

---

Resawing (**Figure 40**) is the process of cutting a board into two or more thinner boards. The maximum board width that can be resawn is limited by the maximum cutting height of the bandsaw. Maximum cutting height for this bandsaw is 10".

The Model G0457 14" Industrial Bandsaw is capable of resawing, provided the saw is properly set up. Attempting to resaw too wide or too dense of a board may put excessive strain on the blade and cause breakage.

One of the most important considerations when resawing is blade selection. Generally, the wider blade, the better. In most applications, a hook or a skip tooth style will be desirable. Also, since most resawn lumber will be planed smooth, you should choose blades with fewer teeth-per-inch (from 3 to 6). While blades with fewer teeth-per-inch produce rougher cuts, these types of blades offer larger gullet capacities for clearing sawdust, reducing heat buildup and reducing strain on the motor.



**Figure 40.** Resawing lumber.



### To resaw a workpiece:

1. Verify that the bandsaw is set up properly and that the table is perpendicular to the blade.
2. Use the widest blade your bandsaw will accept.  
  
**Note:** *The blade must also be sharp and clean.*
3. Use a fence to guide the workpiece.
4. Set your fence to the desired width of cut and lock it in place.
5. Support the ends of the board if necessary.
6. Turn the bandsaw **ON**.
7. Using push paddles and a push stick, keep pressure against the fence and table, and slowly feed the workpiece into the moving blade until the blade is completely through the workpiece.

## Cutting Curves

When cutting curves, simultaneously feed and turn the stock carefully so that the blade follows the layout line without twisting. If a curve is so abrupt that it is necessary to repeatedly back up and cut a new kerf, use either a narrower blade or a blade with more TPI (teeth per inch), or make more relief cuts.

Always make short cuts first, then proceed to the longer cuts. Relief cuts will also reduce the chance that the blade will be pinched or twisted. Relief cuts are cuts made through the waste portion of the workpiece and are stopped at the layout line. As you cut along the layout line, waste wood is released from the workpiece, alleviating any pressure on the back of the blade. Relief cuts also make backing the workpiece out easier, if needed.

### **NOTICE**

The list below displays blade widths and the corresponding minimum radii each size of blade for the Model G0457.

Width	Radius
1/8" .....	1/8"
3/16" .....	3/8"
1/4" .....	5/8"
3/8" .....	1 1/4"
1/2" .....	2 1/2"
5/8" .....	3 3/4"
3/4" .....	5 1/2"



# Stacked Cuts

---

One of the benefits of a bandsaw is its ability to cut multiple copies of a particular shape by stacking a number of workpieces together.

Before making stacked cuts, ensure that both the table and the blade are properly adjusted to 90°. Otherwise, any error will be compounded with each piece cut from the top to the bottom of the stack.

## To complete a stacked cut:

1. Align your pieces from top to bottom to ensure that each piece has adequate scrap to provide a clean, unhampered cut.
  2. Secure all the pieces together in a manner that will not interfere with the cutting. Hot glue on the edges works well, as do brad nails through the waste portion. (Be careful not to cut into the brads!)
  3. On the face of the top piece, lay out the shape you intend to cut.
  4. Make relief cuts perpendicular to the outline of your intended shape in areas where changes in blade direction could strain the woodgrain or cause the blade kerf to bind.
5. Cut the stack of pieces as though you were cutting a single piece. Follow your layout line with the blade kerf on the waste side of your line as shown in **Figure 41**.

## CAUTION

Cutting into brad nails that are used to secure the multiple pieces can cause the blade to break and may cause an injury to the operator. Be extremely careful of where you are cutting when performing this operation.

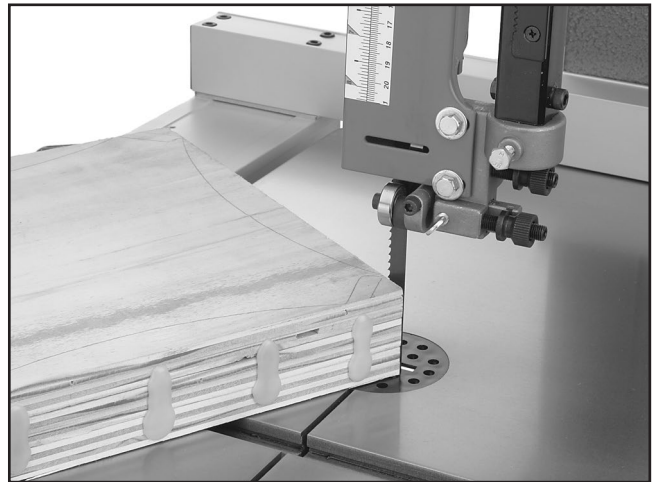

**Figure 41.** Cutting multiple pieces at once.



# Blade Information

Selecting the right blade requires a knowledge of the various blade characteristics mentioned below, the type of material you plan to cut, and the type of cut you are going to perform.

## Blade Length

Measured by the circumference, blade lengths are usually unique to the brand of your bandsaw and the distance between wheels. The Model G0457 is designed for blades that are 106" long. Refer to the current Grizzly catalog for prices and ordering information.

## Blade Width

Measured from the back of the blade to the tip of the blade tooth (the widest point), blade width is often the first consideration given to blade selection. Blade width dictates the largest and smallest curve that can be cut, as well as how accurately it can cut a straight line.

The Model G0457 can use blades from  $\frac{1}{8}$ " to  $\frac{3}{4}$ " in width. Always pick the size of blade that best suits your application.

- **Curve Cutting:** Use the chart in **Figure 42** to determine the correct blade for curve cutting. Determine the smallest radius curve that will be cut on your workpiece and use the corresponding blade width.

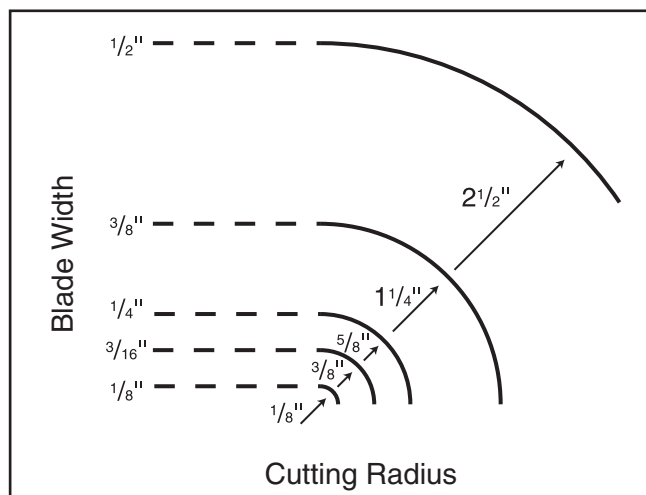

**Figure 42.** Blade width radii.

- **Straight Cutting:** Use the largest width blade that you own. The Model G0457 will accept blades up to  $\frac{3}{4}$ " wide. Narrow blades can cut tight curves (a small radius) but are not very good at cutting straight lines because they naturally wander (blade lead). However, larger blades are much better at cutting straight lines, but function poorly at cutting small curves because of their size.

## Tooth Style

When selecting blades, another option to consider is the shape, gullet size, teeth set and teeth angle—otherwise known as “Tooth Style.”

**Figure 43** shows the three main categories of tooth style:

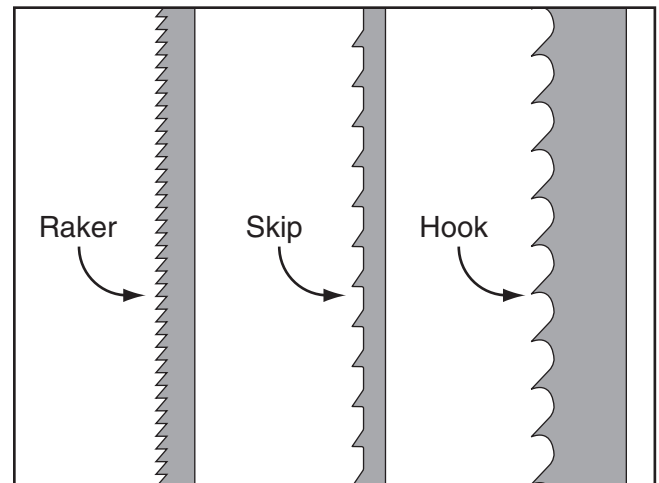

**Figure 43.** Raker, Skip & Hook tooth styles.

- **Raker:** This style is considered to be the standard because the tooth size and shape are the same as the tooth gullet. The teeth on raker blades usually are very numerous, have no angle, and produce cuts by scraping the material; these characteristics result in very smooth cuts, but do not cut fast and generate more heat while cutting.
- **Skip:** This style is similar to a raker blade that is missing every other tooth. Because of the design, skip toothed blades have a much larger gullet than raker blades, and therefore, cut faster and generate more heat. However, these blades also leave a rougher cut than raker blades.



- **Hook:** The teeth on this style have a positive angle (downward) which makes them dig into the material, and the gullets are usually rounded for easier waste removal. These blades are excellent for the tough demands of resawing and ripping thick material.

## Tooth Pitch

Usually measured as TPI (teeth per inch), tooth pitch determines the size of the teeth. More teeth per inch (fine pitch) will cut slower, but smoother; while fewer teeth per inch (coarse pitch) will cut rougher, but faster. As a general rule, choose blades that will have at least three teeth in the material at all times. Use fine pitched blades on harder woods and coarse pitched blades on softer woods.

## Blade Care

A bandsaw blade is a delicate piece of steel that is subjected to tremendous strain. You can obtain longer use from a bandsaw blade if you give it fair treatment and always use the appropriate feed rate for your operation.

Be sure to select blades with the proper width, style, and pitch for each application. The wrong choice of blades will often produce unnecessary heat which will shorten the life of your blade.

A clean blade will perform much better than a dirty blade. Dirty or gummed up blades pass through the cutting material with much more resistance than clean blades. This extra resistance also causes unnecessary heat.

## Blade Breakage

Many conditions may cause a bandsaw blade to break. Blade breakage is unavoidable, in some cases, since it is the natural result of the peculiar stresses that bandsaw blades are subjected to. Blade breakage is also due to avoidable circumstances. Avoidable breakage is most often the result of poor care or judgement on the part of the operator when mounting or adjusting the blade or support guides.

## The most common causes of blade breakage are:

- Aligning or adjusting the guides incorrectly.
- Forcing or twisting a wide blade around a curve of short radius.
- Feeding the workpiece into the blade too fast.
- Using a blade with dull teeth or the absence of sufficient set.
- Incorrect tension.
- Setting the top blade guide assembly set too high above the work piece.
- Using a blade with a lumpy or improperly finished braze or weld.
- Continuously running the bandsaw when not in use.



# Blade Changes

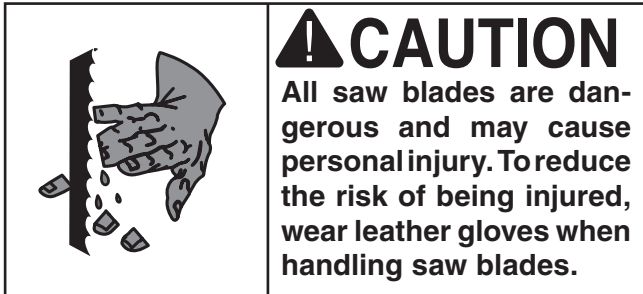
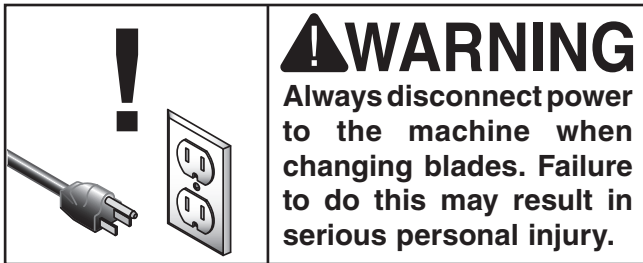

## To remove the blade:

1. DISCONNECT BANDSAW FROM POWER!
2. Release the blade tension by turning the blade tension quick release lever to the left.
3. Remove the table insert and the table pin. Adjust the upper and lower guide bearings as far away as possible from the blade.
4. Open the upper and lower wheel covers, and with gloved hands, slide the blade off both wheels.
5. Rotate the blade 90° and slide it through the slot in the table.

## To replace the blade:

1. Slide the blade through the table slot, ensuring that the teeth are pointing down toward the table.

**Note:** If the teeth will not point downward in any orientation, the blade is inside-out. Put on heavy gloves, remove the blade, and twist it right side-out.

2. Slip the blade through the guides, and mount it on the upper and lower wheels (**Figure 44**).

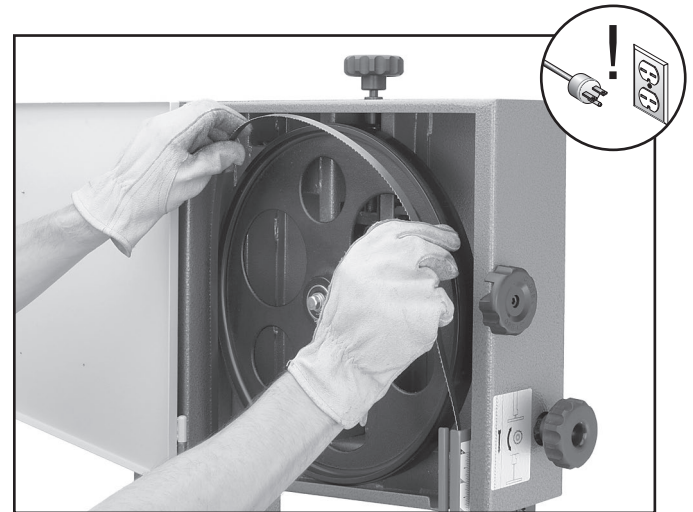

**Figure 44.** Placing blade on the wheels.

3. Tighten the blade tension quick release.
4. Apply tension to the blade by turning the tension control knob. Rotate the upper wheel slowly by hand as tension is applied to allow the blade to center itself on the wheel. Adjust tracking if needed.
5. Adjust tension as described **Page 24**.
6. Adjust the upper/lower guide bearings and the support bearings.
7. Close the wheel covers.
8. Replace the table insert and table pin, being sure not to use excessive force when inserting the table pin.



# SECTION 5: ACCESSORIES

## **!WARNING**

Installing unapproved accessories may cause machine to malfunction, resulting in serious personal injury or machine damage. To reduce this risk, only install accessories recommended for this machine by Grizzly.

## **NOTICE**

Refer to our website or latest catalog for additional recommended accessories.

### Replacement Blades

These 106" long replacement blades are milled for exact tooth set and are made with high quality tool steel.

MODEL	WIDTH	GAUGE	TPI	STYLE
G6638	1/8"	.035	14	Raker
G6639	1/8"	.035	18	Raker
G6640	3/16"	.035	4	Skip
G6641	3/16"	.035	10	Raker
G6642	3/16"	.035	14	Raker
G6643	1/4"	.035	4	Hook
G6644	1/4"	.035	6	Hook
G6645	1/4"	.035	10	Raker
G6646	1/4"	.035	14	Raker
G6647	1/4"	.035	18	Raker
G6648	3/8"	.035	4	Hook
G6649	3/8"	.035	6	Hook
G6650	3/8"	.035	10	Raker
G6651	3/8"	.035	14	Raker
G6652	1/2"	.035	3	Hook
G6653	1/2"	.035	4	Hook
G6654	1/2"	.035	6	Hook
G6655	1/2"	.035	10	Raker
G6656	1/2"	.035	14	Raker
G6657	3/4"	.035	3	Hook
G6658	3/4"	.035	6	Hook
G6659	3/4"	.035	10	Raker

### Basic Eye Protection

T20501—Face Shield Crown Protector 4"

T20502—Face Shield Crown Protector 7"

T20503—Face Shield Window

T20451—"Kirova" Clear Safety Glasses

T20452—"Kirova" Anti-Reflective S. Glasses

T20456—DAKURA Safety Glasses, Black/Clear



Figure 45. Assortment of basic eye protection.

H4978—Deluxe Earmuffs - 27dB

H4979—Twin Cup Hearing Protector - 29dB

T20446—Classic Earplugs, 200-pair - 31dB

Protect yourself comfortably with a pair of cushioned earmuffs. Especially important if you or employees operate for hours at a time.



Figure 46. Hearing protection.

**order online at [www.grizzly.com](http://www.grizzly.com) or call 1-800-523-4777**



- H2499—Small Half-Mask Respirator**
- H3631—Medium Half-Mask Respirator**
- H3632—Large Half-Mask Respirator**
- H3635—Cartridge Filter Pair P100**

Wood dust has been linked to nasal cancer and severe respiratory illnesses. If you work around dust everyday, a half-mask respirator can be a lifesaver. Also compatible with safety glasses!



**Figure 47.** Half-mask respirator with disposable cartridge filters.

- G5562—SLIPIT® 1 Qt. Gel**
- G5563—SLIPIT® 12 Oz. Spray**
- G2871—Boeshield® T-9 12 Oz. Spray**
- G2870—Boeshield® T-9 4 Oz. Spray**
- H3788—G96® Gun Treatment 12 Oz. Spray**
- H3789—G96® Gun Treatment 4.5 Oz. Spray**



**Figure 48.** Recommended products for protecting unpainted cast iron/steel part on machinery.

- H5408—Blade Tensioning Gauge**
- The Blade Tensioning Gauge ensures long blade life, reduced blade breakage, and straight cutting by indicating correct tension. A precision dial indicator provides you with a direct readout in PSI.

The Blade Tensioning Gauge is made of light-weight, cast aluminum for optimum accuracy. Bright color coding makes it easy to use and easy to read. The Blade Tensioning Gauge comes in a handy metal box with instructions on the lid.



**Figure 49.** H5408 Blade Tensioning Gauge.

- D2057A—Heavy-Duty Shop Fox® Mobile Base**
- This patented base is the most stable on the market with outrigger type supports. Adjusts from 20" x 20" to 29½" x 29½". 700 lb. capacity. Weighs 34 lbs.



**Figure 50.** D2057A Shop Fox Mobile Base.

**order online at [www.grizzly.com](http://www.grizzly.com) or call 1-800-523-4777**



### T26403—The Missing Shop Manual: Bandsaw

Dedicated to providing integral information about woodworking tools and techniques that other manuals overlook, the books in this series contain safety facts, explanations about basic project set up, and tips for maximizing tool performance. In Bandsaw, you will find out how to best utilize this essential workshop tool, and how to get the most for your money by getting the most from your equipment. Filled with clear diagrams and instructions, this pocket sized durable manual is ideal for quick reference in the workshop. 112 pages, soft cover.

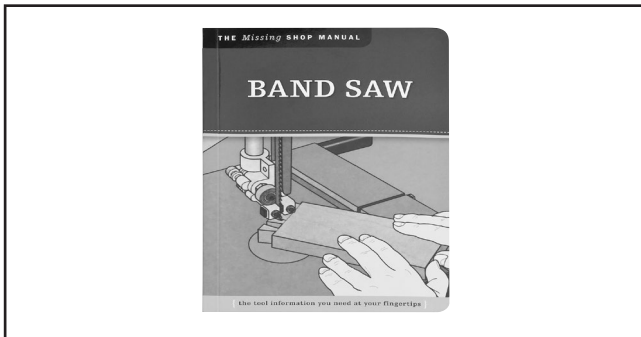

Figure 51. The Missing Shop Manual: Bandsaw.

### G9256—6" Dial Caliper

### G9257—8" Dial Caliper

### G9258—12" Dial Caliper

These traditional dial calipers are accurate to 0.001" and can measure outside surfaces, inside surfaces, and heights/depths. Features stainless steel, shock resistant construction and a dust proof display. An absolute treat for the perfectionist!

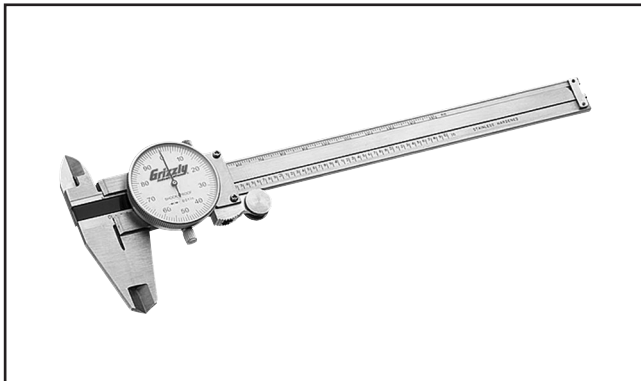

Figure 52. Grizzly® Dial Calipers.

### D2272—Tilting Roller Stand

Adjusts from 26" to 44", 0°-45°. 150 lb. capacity.

### D2273—Single Roller Stand

Adjusts from 26 5/8" to 45". 250 lb. capacity.

### D2274—5 Roller Stand

Adjusts from 26" to 44 5/8". 250 lb. capacity.

These super heavy-duty roller stands feature convenient hand knobs for fast height adjustment.



Figure 53. SHOP FOX® Roller Stands.

### G5683—Magnetic Base Light

Light up your work just where you need it. Flexible neck lamp features magnetic base that attaches with the twist of a switch so you can use it on every machine. 110V. Maximum 60 watt bulb.



Figure 54. Magnetic Base Light.

**order online at [www.grizzly.com](http://www.grizzly.com) or call 1-800-523-4777**



# SECTION 6: MAINTENANCE

---

---

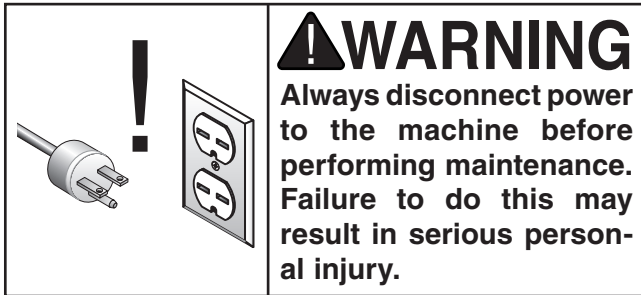

## Schedule

---

For optimum performance from this machine, this maintenance schedule must be strictly followed.

### Ongoing

To maintain a low risk of injury and proper machine operation, if you ever observe any of the items below, shut down the machine immediately and fix the problem before continuing operations:

- Loose mounting bolts.
- Worn or damaged saw blade.
- Worn or damaged wires.
- Any other unsafe condition.

### Monthly

- Check for V-belt tension, damage, or wear.
- Clean/vacuum dust buildup from inside cabinet and off motor.

## Cleaning & Protecting

---

---

Cleaning the bandsaw is relatively easy. Vacuum excess wood chips and sawdust, and wipe off the remaining dust with a dry cloth. If any resin has built up, use a resin dissolving cleaner to remove it.

Protect the unpainted cast iron surfaces on the table by wiping it clean after every use—this ensures moisture from wood dust does not remain on bare metal surfaces. Keep the table rust-free with regular applications of products like G96® Gun Treatment, SLIPIT®, or Boeshield® T-9 (see **Accessories** section for more details).

Once a month, remove the blade and thoroughly clean all built-up sawdust from the rubber tires on the wheels.

## Lubrication

---

---

Sealed and pre-lubricated ball bearings require no lubrication for the life of the bearings. All bearings are standard sizes, and replacements can be purchased from our parts department or bearing supply store.

For adjustment controls, an occasional “shot” of light oil is all that is necessary. Wipe off any sawdust with a clean cloth, towel or dry paint brush, and spray on the lubricant. Do not get oil on the pulleys or V-belt because it could cause belt deterioration and slipping.



## Guide Post

1. DISCONNECT BANDSAW FROM POWER!
2. Open the upper wheel cover, then lower the guide post so the upper guide bearings almost touch the table.
3. Wipe the old grease off the rack (the long plate with teeth). The old grease will be contaminated with sawdust, so you want to remove as much of it as possible (**Figure 55**).

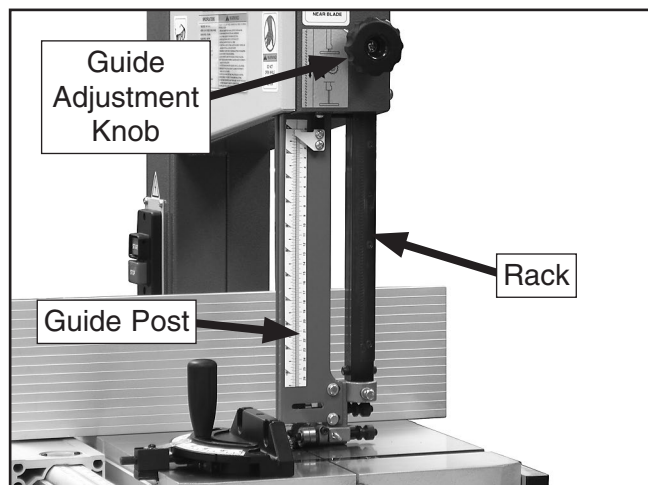
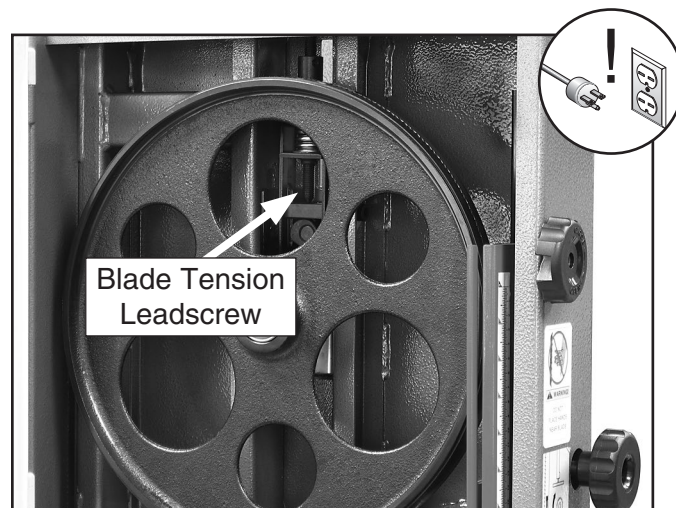

**Figure 55.** Guide post rack lubrication.

4. Use mineral spirits or degreaser to clean any remaining grease from the rack. Make sure to thoroughly wipe off the degreaser or mineral spirits after use so they won't contaminate the new grease.
5. Use a small, clean brush to apply NLGI#2 or equivalent automotive-grade multi-purpose grease to the rack. After applying, rotate the guide adjustment knob several times to distribute the grease.
6. Close the upper wheel cover, and re-adjust the guide post height as necessary.

## Blade Tension Leadscrew

1. DISCONNECT BANDSAW FROM POWER!
2. Open the upper wheel cover, then wipe as much of the old grease off the blade tension leadscrew as possible. The old grease will be contaminated with sawdust, so you want to remove as much of it as possible (**Figure 35**).



**Figure 56.** Blade tension leadscrew.

3. Use mineral spirits or degreaser to clean any remaining grease from the leadscrew. Make sure to thoroughly wipe off the degreaser or mineral spirits after use so they will not contaminate the new grease.
4. Use a small, clean brush to apply NLGI#2 or equivalent automotive-grade multi-purpose grease to the leadscrew. After applying, rotate the blade tension knob through its full range of motion to distribute the grease.
5. Close the upper wheel cover, and re-adjust the blade and belt tension as necessary.



## Table Trunnions

1. DISCONNECT BANDSAW FROM POWER!
2. Wipe the old grease off the bearing surfaces of the table trunnions. Start with the outward side of the table trunnions (**Figure 57**) when the table is at 0°, then tilt the table to 45° and wipe off the inward side. The old grease will be contaminated with sawdust, so you want to remove as much of it as you can.

**Note:** For easiest access to the trunnions and the best cleaning results, consider removing the table during this procedure.

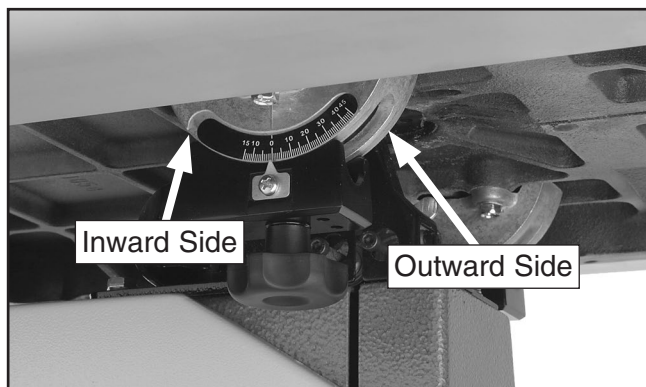

**Figure 57.** Sides of table trunnions to grease.

3. Use mineral spirits or degreaser to clean any remaining grease from the trunnions. Make sure to thoroughly wipe off the degreaser or mineral spirits after use so they won't contaminate the new grease.
4. Use a small, clean brush to apply NLGI#2 or equivalent automotive-grade multi-purpose grease to the trunnion bearing surfaces. After applying, tilt the table back and forth from 0° to 45° to distribute the grease.

## Redressing Rubber Tires

As the bandsaw ages, the rubber tires on the wheels may need to be redressed if they harden or glaze over. Redressing the rubber tires improves blade tracking and reduces vibration/blade lead.

If the rubber tires become too worn, then blade tracking will become extremely difficult. At that point, redressing will no longer be effective and the rubber tires must be replaced.

### To redress the rubber tires:

1. DISCONNECT BANDSAW FROM POWER!
2. Put on heavy leather gloves.
3. Remove the blade.
4. Clean any built-up sawdust from the rubber tires.
5. Hold 100 grit sandpaper against the rubber tire and rotate the wheel by hand. Only redress the rubber enough to expose a fresh rubber surface.



# SECTION 7: SERVICE

Review the troubleshooting procedures in this section if a problem develops with your machine. If you need replacement parts or additional help with a procedure, call our Technical Support. **Note:** *Please gather the serial number and manufacture date of your machine before calling.*

## Troubleshooting

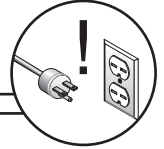

### Motor & Electrical

Symptom	Possible Cause	Possible Solution
Machine does not start or a breaker trips.	<ol style="list-style-type: none"> <li>1. Plug/receptacle is at fault or wired incorrectly.</li> <li>2. Motor connection wired incorrectly.</li> <li>3. Power supply is at fault/switched OFF.</li> <li>4. Motor ON/OFF switch is at fault.</li> <li>5. Wiring is open/has high resistance.</li> <li>6. Start capacitor is at fault.</li> <li>7. Motor is at fault.</li> </ol>	<ol style="list-style-type: none"> <li>1. Test for good contact or correct the wiring.</li> <li>2. Correct motor wiring connections (<b>Page 51</b>).</li> <li>3. Ensure hot lines have correct voltage on all legs and main power supply is switched ON.</li> <li>4. Replace faulty ON/OFF switch.</li> <li>5. Check for broken wires or corroded/disconnected connections, and repair/replace as necessary.</li> <li>6. Test/replace if faulty.</li> <li>7. Repair/replace.</li> </ol>
Machine stalls or is underpowered.	<ol style="list-style-type: none"> <li>1. Wrong workpiece material (wood).</li> <li>2. Processing speed too fast for task.</li> <li>3. Low power supply voltage.</li> <li>4. Run capacitor is at fault.</li> <li>5. V-belt slipping.</li> <li>6. Plug/receptacle is at fault.</li> <li>7. Motor connection is wired incorrectly.</li> <li>8. Blade is slipping on wheels.</li> <li>9. Motor bearings are at fault.</li> <li>10. Motor has overheated.</li> <li>11. Motor is at fault.</li> </ol>	<ol style="list-style-type: none"> <li>1. Use wood with correct moisture content, without glues, and little pitch/resins.</li> <li>2. Decrease processing speed. See <b>Basic Cutting Tips</b> on <b>Page 28</b>.</li> <li>3. Ensure all hot lines have correct voltage on all legs.</li> <li>4. Repair/replace.</li> <li>5. Replace bad V-belt, align pulleys, and re-tension (<b>Page 46</b>).</li> <li>6. Test for good contacts and correct wiring.</li> <li>7. Correct motor wiring connections (<b>Page 51</b>).</li> <li>8. Adjust blade tracking (<b>Page 20</b>) and tension (<b>Page 24</b>) to factory specifications.</li> <li>9. Test by rotating shaft; rotational grinding/loose shaft requires bearing replacement.</li> <li>10. Clean off motor, let cool, and reduce workload.</li> <li>11. Repair/replace.</li> </ol>



Symptom	Possible Cause	Possible Solution
Machine has vibration or noisy operation when running.	<ol style="list-style-type: none"> <li>1. Motor or component is loose.</li> <li>2. V-belt worn or loose.</li> <li>3. Motor fan is rubbing on fan cover.</li> <li>4. Pulley is loose.</li> <li>5. Machine is incorrectly mounted or sits unevenly on floor.</li> <li>6. Motor bearings are at fault.</li> <li>7. Blade weld is at fault or teeth are broken.</li> <li>8. Worn arbor bearings.</li> <li>9. Wheels not coplanar/aligned correctly.</li> <li>10. Tires incorrectly installed.</li> <li>11. Bent or worn out blade.</li> <li>12. Wheels out of balance.</li> </ol>	<ol style="list-style-type: none"> <li>1. Inspect/replace stripped or damaged bolts/nuts, and re-tighten with thread locking fluid.</li> <li>2. Inspect/replace belt (<b>Page 46</b>).</li> <li>3. Replace dented fan cover and loose/damaged fan.</li> <li>4. Realign/replace shaft, pulley, set screw, and key as required.</li> <li>5. Adjust the feet on the bottom of the stand; relocate machine.</li> <li>6. Test by rotating shaft — rotational grinding/loose shaft requires bearing replacement.</li> <li>7. Replace blade (<b>Page 36</b>).</li> <li>8. Check/replace arbor bearings.</li> <li>9. Adjust wheel alignment to coplaner (<b>Page 49</b>).</li> <li>10. Re-install tires.</li> <li>11. Replace blade (<b>Page 36</b>).</li> <li>12. Replace wheels.</li> </ol>

## Cutting Operations



Symptom	Possible Cause	Possible Solution
Machine slows when operating.	<ol style="list-style-type: none"> <li>1. Applying too much pressure to workpiece.</li> <li>2. Blade is dull.</li> </ol>	<ol style="list-style-type: none"> <li>1. Feed workpiece slower. See <b>Basic Cutting Tips</b> on <b>Page 28</b>.</li> <li>2. Replace blade (<b>Page 36</b>).</li> </ol>
Ticking sound when the saw is running.	<ol style="list-style-type: none"> <li>1. Blade weld contacting support bearing.</li> <li>2. Blade weld may be failing.</li> </ol>	<ol style="list-style-type: none"> <li>1. Use file or stone to smooth and round the back of the blade.</li> <li>2. Inspect and replace blade if necessary (<b>Page 36</b>).</li> </ol>
Blade contacting table insert.	<ol style="list-style-type: none"> <li>1. Excessive side pressure when cutting.</li> <li>2. Table improperly adjusted.</li> </ol>	<ol style="list-style-type: none"> <li>1. Reduce side pressure.</li> <li>2. Adjust table (<b>Page 22</b>).</li> </ol>
Vibration when cutting.	<ol style="list-style-type: none"> <li>1. Loose or damaged blade.</li> </ol>	<ol style="list-style-type: none"> <li>1. Tighten or replace blade. See <b>Page 24 or 36</b>.</li> </ol>
Burn marks on the edge of the cut.	<ol style="list-style-type: none"> <li>1. Too much side pressure when feeding workpiece.</li> <li>2. Blade too wide for size of radius being cut.</li> </ol>	<ol style="list-style-type: none"> <li>1. Feed workpiece straight into the blade. See <b>Basic Cutting Tips</b> on <b>Page 28</b>.</li> <li>2. Install a smaller width blade/increase blade tension. See <b>Page 24 or 36</b>.</li> </ol>
Rough or poor quality cuts.	<ol style="list-style-type: none"> <li>1. Feeding workpiece too fast.</li> </ol>	<ol style="list-style-type: none"> <li>1. Reduce feed rate. See <b>Basic Cutting Tips</b> on <b>Page 28</b>.</li> </ol>
Sawdust buildup inside cabinet.	<ol style="list-style-type: none"> <li>1. Clogged dust port.</li> <li>2. Low CFM (airflow) from dust collection system.</li> </ol>	<ol style="list-style-type: none"> <li>1. Clean out dust port.</li> <li>2. Three options: <ul style="list-style-type: none"> <li>—Check dust lines for leaks or clogs.</li> <li>—Move dust collector closer to saw.</li> <li>—Install a stronger dust collector.</li> </ul> </li> </ol>
Blade wanders or won't follow line of cut.	<ol style="list-style-type: none"> <li>1. Blade lead.</li> </ol>	<ol style="list-style-type: none"> <li>1. Refer to Blade Lead on <b>Page 47</b>.</li> </ol>



# Checking V-Belt

To ensure optimum power transmission from the motor to the blade, the V-belt must be in good condition and operate under proper tension. The belt should be checked for cracks, fraying, and wear. Belt tension should be checked at least every 3 months—more often if the bandsaw is used daily.

## To check the V-belt:

1. DISCONNECT BANDSAW FROM POWER!
2. Open the lower wheel cover.
3. Push the center of the V-belt. Note the amount of deflection.  
—If deflection is more than  $\frac{3}{8}$ ", tighten the V-belt.
4. Note the condition of the V-belt.  
—If the V-belt is cracked, frayed, or glazed; it should be replaced as soon as convenient.

# Tensioning V-Belt

Tools Needed:	Qty
Hex Wrench 6mm.....	1

## To tension the V-belt:

1. DISCONNECT BANDSAW FROM POWER!
2. Open the lower wheel cover.
3. Loosen the motor mount screws shown in **Figure 58**.

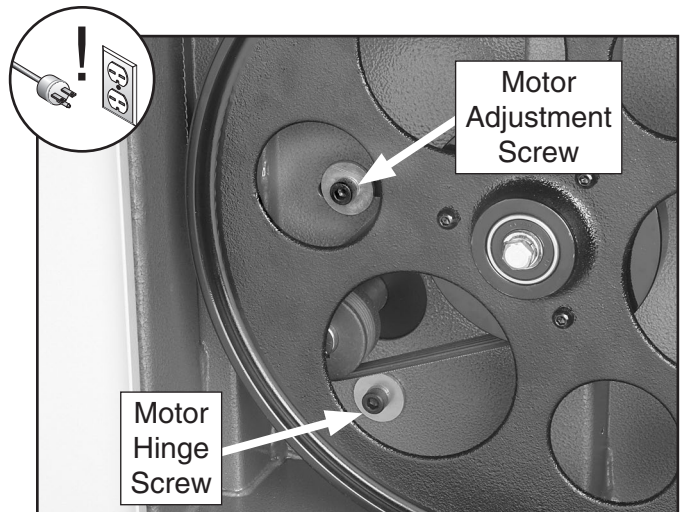

**Figure 58.** Motor mount screws.

4. Move the body of the motor, sliding the adjustment screw to the left-hand side (facing bandsaw front) of the adjustment slot.
5. Hold the motor in position with one hand and tighten the motor adjustment screw with the other hand.
6. Push the center of the V-belt.  
—If deflection is approximately  $\frac{3}{8}$ " with moderate pressure from your thumb or finger (**Figure 59**), then the tension is correct.  
—If the deflection is more than  $\frac{3}{8}$ ", repeat **Steps 3-6**.

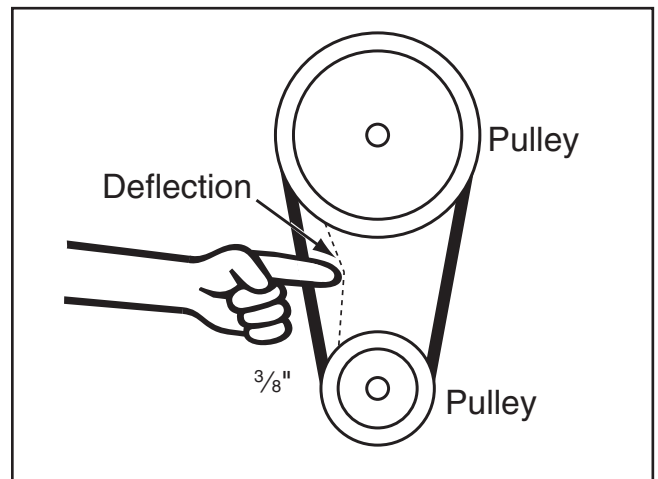

**Figure 59.** Testing belt tension.

7. When the V-belt tension is correct, tighten the motor hinge screw and close the lower wheel cover.



# Replacing V-Belt

Tools Needed:	QTY
Hex Wrench 6mm.....	1
Wrench 13mm .....	1

## To replace the V-belt:

1. DISCONNECT BANDSAW FROM POWER!
2. Open both wheel covers, and remove the blade.
3. Loosen the motor screws shown in **Figure 58**.
4. Unthread the wheel mount bolt shown in **Figure 60** and slide the lower wheel off of the bearing shaft.

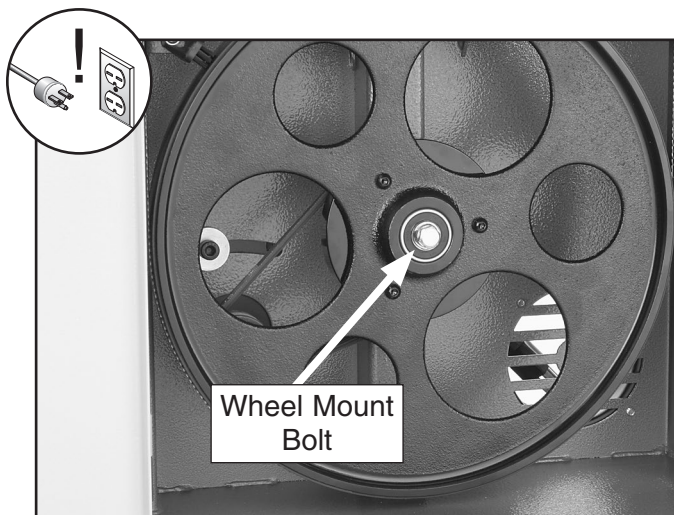

**Figure 60.** Wheel mount bolt.

5. Move the body of the motor so that the motor adjustment screw slides to the right-hand side (facing bandsaw front) of the adjustment slot and pull the V-belt off of the motor pulley.
6. Slip the old V-belt off of the wheel pulley and install the new V-belt in its place.
7. Install the lower wheel back onto the bearing shaft and replace/tighten the wheel mount bolt.
8. Position the V-belt over the motor pulley. Move the body of the motor so that the motor adjustment screw slides to the left-hand side (facing bandsaw front) of the adjustment slot.
9. Hold the motor in position with one hand and tighten the motor adjustment screw with the other hand.
10. Check the V-belt tension and adjust if necessary as described in the **Tensioning V-Belt** instructions on **Page 45**.
11. When the V-belt tension is correct, tighten the motor hinge bolt, replace the blade, then close both wheel covers.



# Shimming Table

To ensure accuracy when cutting stacked workpieces, the table should be 90° to the back of the blade as shown in **Figure 61**. If the table is not perpendicular to the back of the blade, the table needs to be shimmed.

Shims can be made of any durable object that can be sandwiched between the table and the trunnions. We recommend using shim washers or shim stock because of the wide range of available thicknesses. These items can be purchased at your local hardware store.

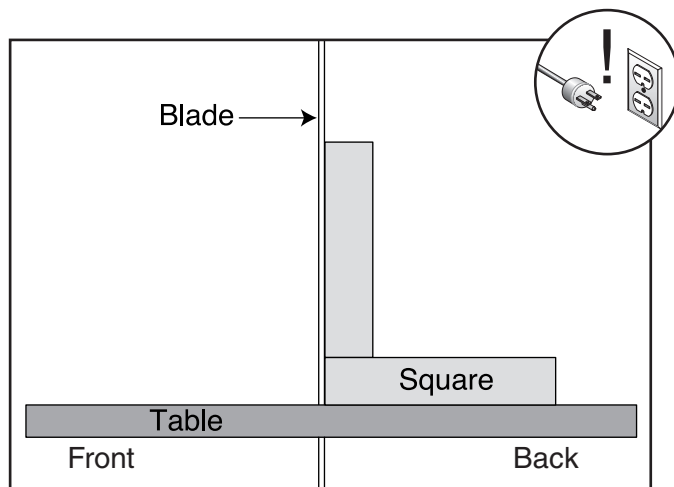

**Figure 61.** Squaring table to blade back.

## To shim the table:

1. Make sure that the blade is tracking properly and that it is correctly tensioned.
2. **DISCONNECT BANDSAW FROM POWER!**
3. Loosen the table mounting bolts that secure the table to the trunnion.
4. Place shims between the table and the trunnion to position the table in the desired direction.
5. Follow the **Aligning Table** instructions on **Page 22** to complete this procedure.

# Blade Lead

Bandsaw blades sometimes wander off the cut line when sawing, as shown in **Figure 62**. This is called blade lead. Blade lead is commonly caused by too fast of a feed rate, a dull or abused blade, or improper tension. If your blade is sharp/undamaged and you still have blade lead, perform the following instructions.



**Figure 62.** Blade leading away from line of cut.

## Correct blade lead

1. Use less pressure when feeding the workpiece through the cut.
2. Check that the miter slot or fence is parallel to the blade line, and correct if necessary.
3. Check for proper blade tension. If the blade tension is correct and it is not convenient to replace the blade, compensate for lead by skewing the fence or adjusting the table.

## Skewing your fence

1. Cut a piece of scrap wood approximately  $\frac{3}{4}$ " thick x 3" wide x 17" long. On a wide face of the board, draw a straight line parallel to the long edge.
2. Cut halfway through the board on the line by pushing it into the blade. Turn the bandsaw **OFF** and wait for the blade to stop.



3. Clamp the board to the bandsaw table without moving it. Now slide the fence over to the board so it barely touches one end of the board.
4. Loosen the four cap screws on top of the fence.
5. Skew the fence so it is parallel to the edge of the scrap piece. You may need to re-adjust the fence locking mechanisms to gain maximum adjustment.
6. While maintaining the skew, tighten the cap screws.

## ***NOTICE***

Lead adjustments will change when new blades are mounted on the saw.

## **Shifting Table**

1. On a scrap piece of wood, mark a line that is perpendicular to the front edge.
2. Cut halfway through the board on the line by pushing it into the blade.
3. Turn the bandsaw **OFF** and wait for the blade to stop.
4. Loosen the table mounting bolts, shift the table to compensate for the blade lead, then retighten the bolts.
5. Repeat **Steps 1–4** until the blade cuts straight.

## ***NOTICE***

If the table is shifted, the fence will need to be re-aligned, and the blade guides and blade support will need to be re-adjusted.



# Wheel Alignment

<b>Components and Hardware Needed:</b>	<b>Qty</b>
45 <sup>1</sup> / <sub>2</sub> " Long 2x4 .....	1

**Tools Needed:**

Wrench 13mm .....	1
Tape Measure.....	1
Coplanarity Gauge (see <b>Figure 63</b> ).....	1

Wheel alignment is one of the most critical factors for optimal performance from your bandsaw.

Heat, vibration, wandering, blade wear, tire wear and overall bandsaw wear are considerably decreased when the wheels are properly aligned or "coplanar."

Coplanar wheels automatically track the blade by balancing it on the crown of the wheel. This is known as coplanar tracking.

**To check if your wheels are coplanar:**

1. Make the "Coplanarity Gauge" shown in **Figure 63**.

**Note:** For best results, straighten the 2x4 with a jointer before cutting.

2. Remove the fence and table, then open both wheel covers.
3. Make sure the guide blocks and rear support bearings are away from the blade, then tighten your blade to the tension that it will be used during operation.
4. Place your coplanarity gauge up against both wheels in the positions shown in **Figure 64**.
5. The adjustment hub allows you to move the lower wheel tilt vertically and horizontally.

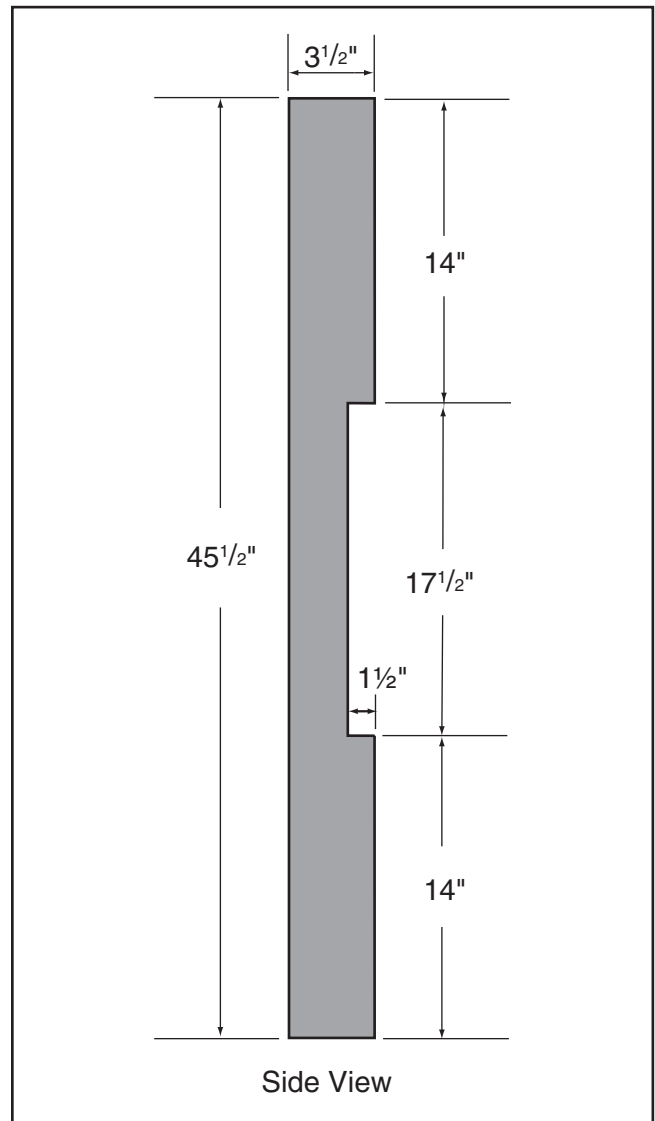

**Figure 63.** Dimensions of coplanarity gauge.

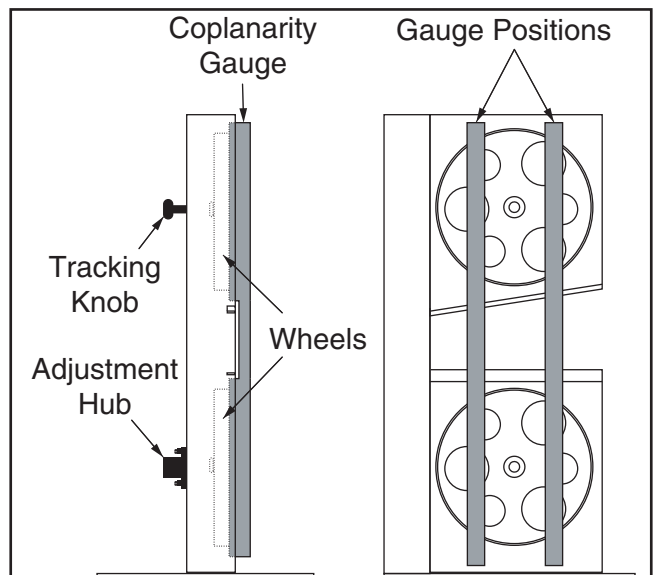

**Figure 64.** Checking for coplanarity.



6. Adjust the tracking knob to get both wheels parallel. If the wheels won't go parallel to each other, then move the lower wheel at the adjustment hub so they line up.
7. If the wheels will go parallel but not coplanar, then move the lower wheel at the adjustment hub (**Figure 65**) as necessary.
8. **Figure 66** shows the positions of the wheels when coplanar. When your wheels are coplanar, readjust the guide blocks and rear support bearings, and replace the wheel covers.

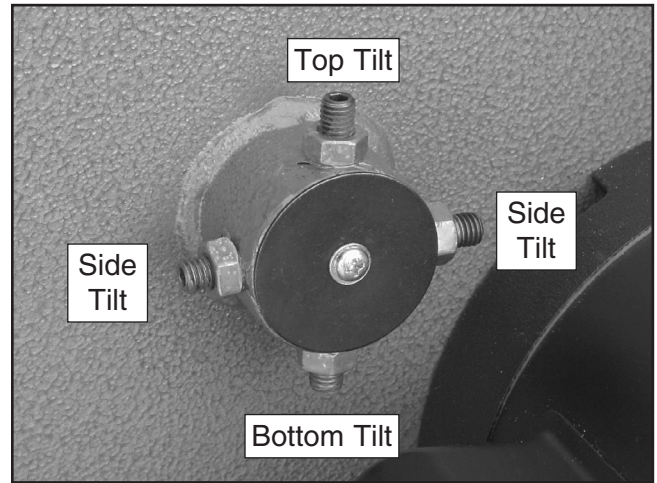

**Figure 65.** Lower wheel adjustment control.

**Note:** *The blade may track slightly **OFF** center when the wheels are coplanar. This is natural because the blade will be balanced **ON** the crown of the tire, rather than just in the center of the tire. This will be more noticeable with larger blades.*

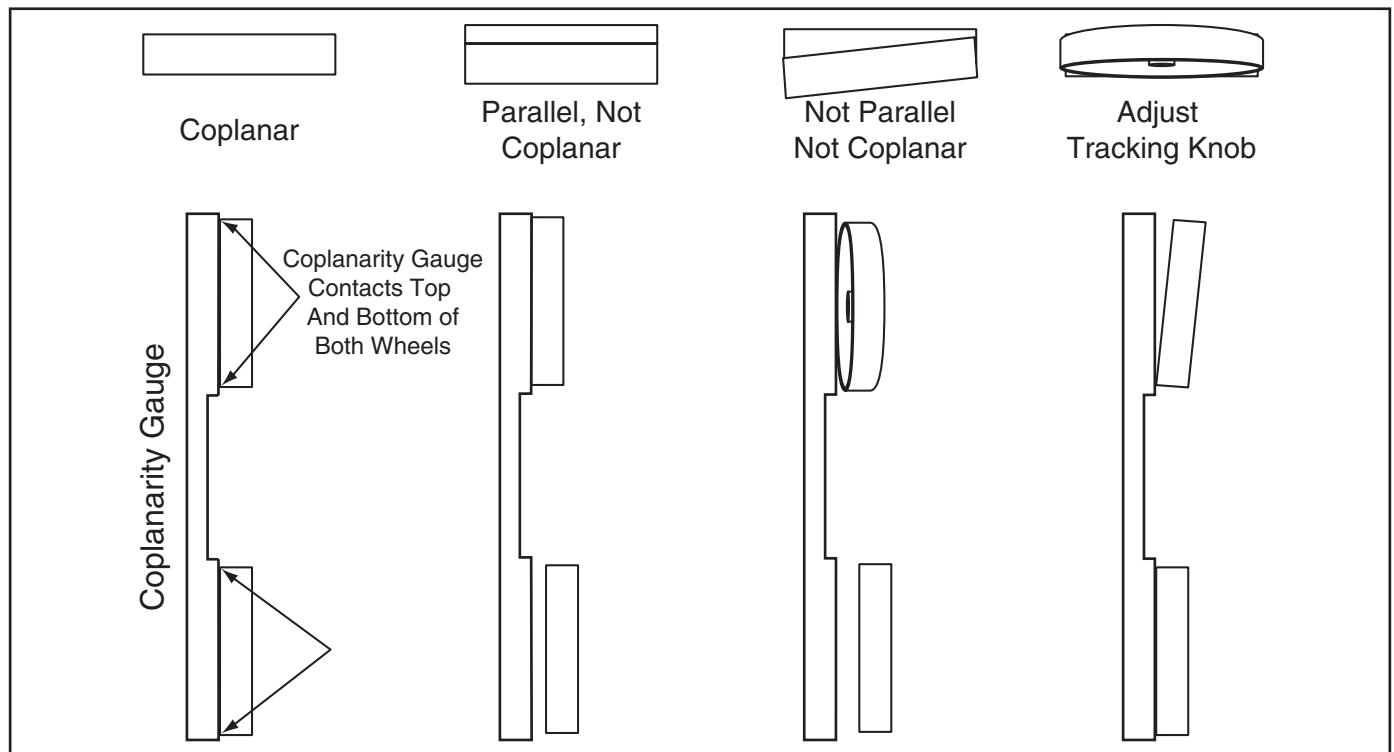

**Figure 66.** Coplanarity diagram.



# SECTION 8: WIRING

These pages are current at the time of printing. However, in the spirit of improvement, we may make changes to the electrical systems of future machines. Compare the manufacture date of your machine to the one stated in this manual, and study this section carefully.

If there are differences between your machine and what is shown in this section, call Technical Support at (570) 546-9663 for assistance BEFORE making any changes to the wiring on your machine. An updated wiring diagram may be available. **Note:** *Please gather the serial number and manufacture date of your machine before calling. This information can be found on the main machine label.*

## WARNING

### Wiring Safety Instructions

**SHOCK HAZARD.** Working on wiring that is connected to a power source is extremely dangerous. Touching electrified parts will result in personal injury including but not limited to severe burns, electrocution, or death. Disconnect the power from the machine before servicing electrical components!

**MODIFICATIONS.** Modifying the wiring beyond what is shown in the diagram may lead to unpredictable results, including serious injury or fire. This includes the installation of unapproved after-market parts.

**WIRE CONNECTIONS.** All connections must be tight to prevent wires from loosening during machine operation. Double-check all wires disconnected or connected during any wiring task to ensure tight connections.

**CIRCUIT REQUIREMENTS.** You MUST follow the requirements at the beginning of this manual when connecting your machine to a power source.

**WIRE/COMPONENT DAMAGE.** Damaged wires or components increase the risk of serious personal injury, fire, or machine damage. If you notice that any wires or components are damaged while performing a wiring task, replace those wires or components.

**MOTOR WIRING.** The motor wiring shown in these diagrams is current at the time of printing but may not match your machine. If you find this to be the case, use the wiring diagram inside the motor junction box.















**CAPACITORS/INVERTERS.** Some capacitors and power inverters store an electrical charge for up to 10 minutes after being disconnected from the power source. To reduce the risk of being shocked, wait at least this long before working on capacitors.

**EXPERIENCING DIFFICULTIES.** If you are experiencing difficulties understanding the information included in this section, contact our Technical Support at (570) 546-9663.

#### NOTICE

The photos and diagrams included in this section are best viewed in color. You can view these pages in color at [www.grizzly.com](http://www.grizzly.com).

#### COLOR KEY

BLACK 	BLUE 	YELLOW 	LIGHT BLUE 
WHITE 	BROWN 	YELLOW GREEN 	BLUE WHITE 
GREEN 	GRAY 	PURPLE 	TURQUOISE 
RED 	ORANGE 	PINK 	



# Wiring Diagram

PUSH BUTTON SWITCH  
(viewed from behind)

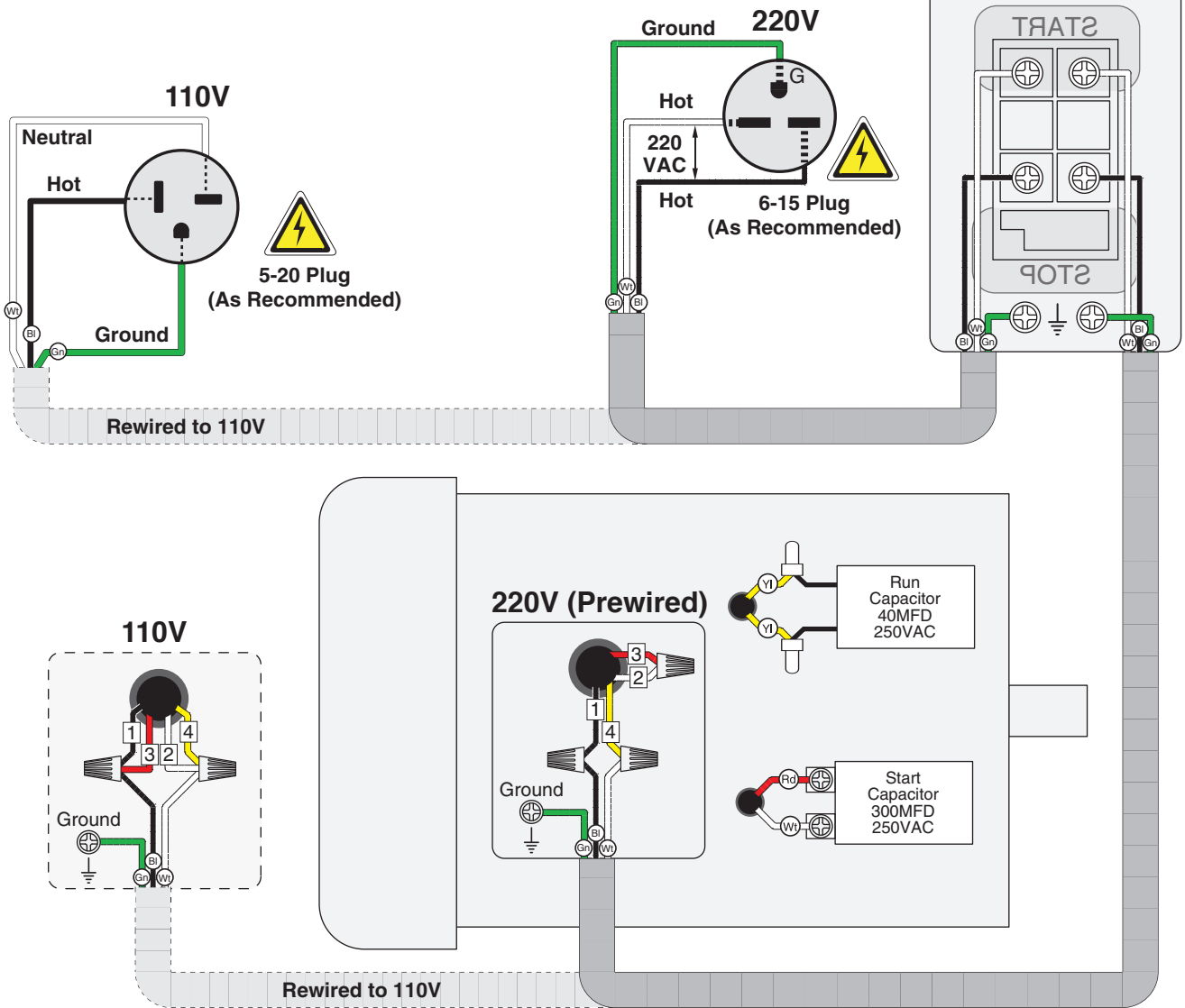

Figure 67. 220V motor wiring.

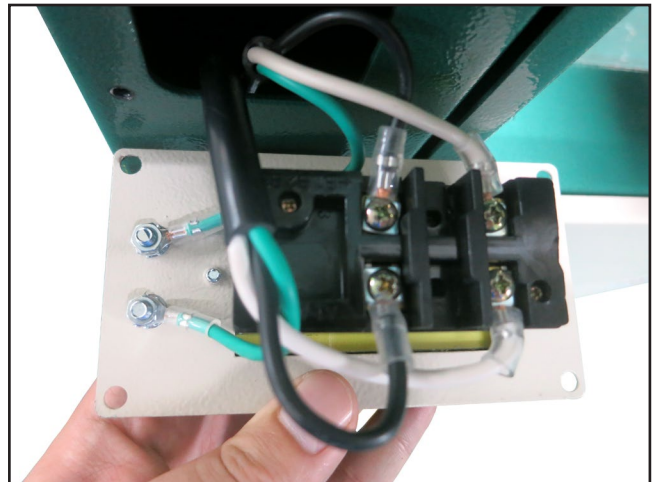
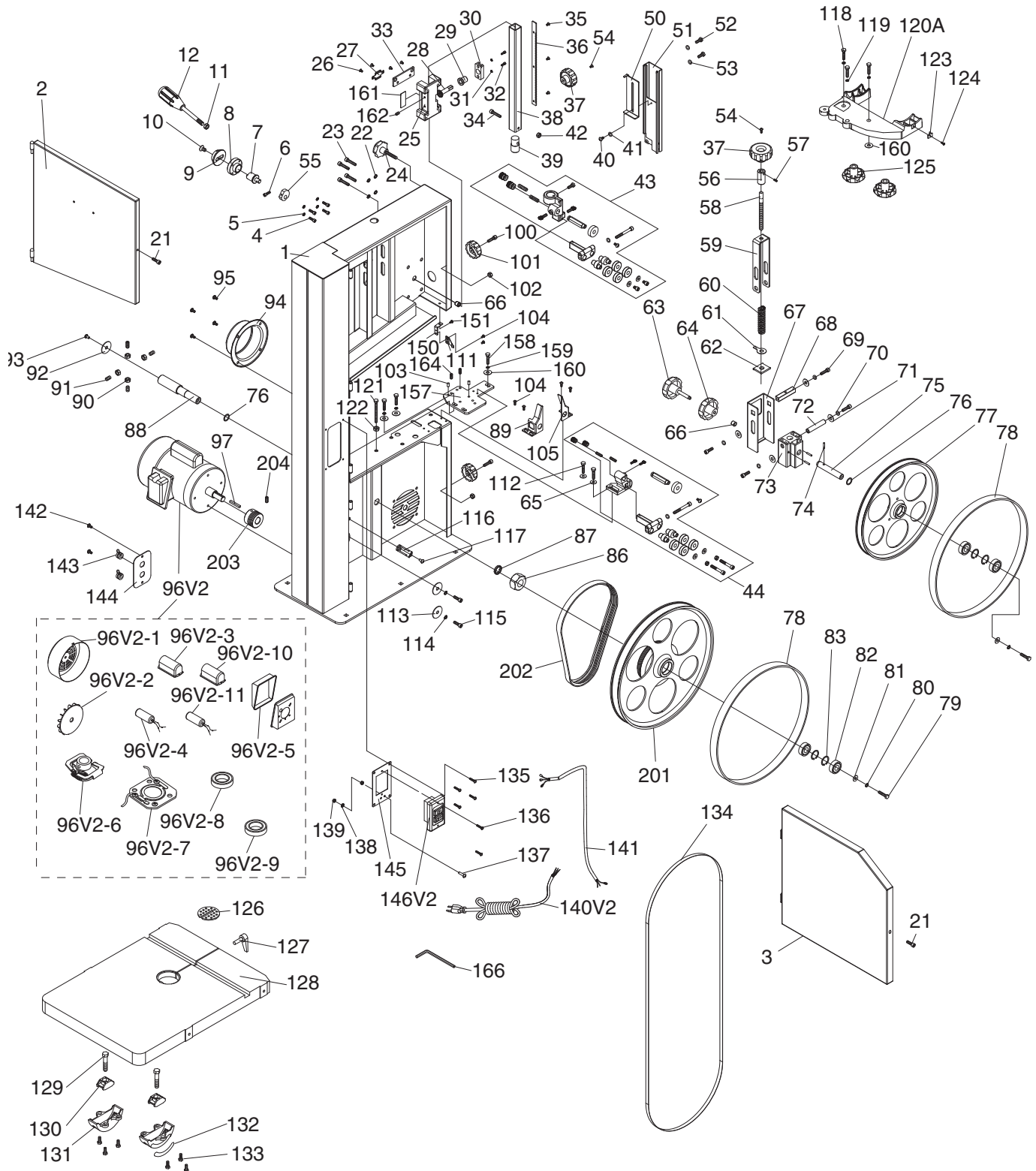

Figure 68. Push button switch wiring.



# SECTION 9: PARTS

## Main



**Please Note:** We do our best to stock replacement parts whenever possible, but we cannot guarantee that all parts shown here are available for purchase. Call (800) 523-4777 or visit our online parts store at [www.grizzly.com](http://www.grizzly.com) to check for availability.



# Main Parts List

REF	PART #	DESCRIPTION
1	P0457001	BODY
2	P0457002	UPPER WHEEL DOOR
3	P0457003	LOWER WHEEL DOOR
4	P0457004	CAP SCREW M6-1 X 10
5	P0457005	LOCK WASHER 6MM
6	P0457006	CAP SCREW M5-.8 X 12
7	P0457007	BIAS SHAFT
8	P0457008	BIAS SHAFT CLAMP SEAT
9	P0457009	TENSION ADJUSTMENT HUB
10	P0457010	CAP SCREW M8-1.25 X 20
11	P0457011	HEX NUT M8-1.25
12	P0457012	TENSION HANDLE
21	P0457021	CAP SCREW M6-1 X 10
22	P0457022	LOCK WASHER 8MM
23	P0457023	CAP SCREW M8-1.25 X 20
24	P0457024	LOCK KNOB M8-1.25 X 20
25	P0457025	UPPER GUIDE POST SUPPORT
26	P0457026	FLAT HD SCR M4-.7 X 6
27	P0457027	SPRING TENSIONER
28	P0457028	ADJUSTMENT GEAR SHAFT
29	P0457029	BUSHING
30	P0457030	GEAR SHAFT BRACKET
31	P0457031	LOCK WASHER 6MM
32	P0457032	CAP SCREW M6-1 X 10
33	P0457033	COVER PLATE
34	P0457034	CAP SCREW M6-1 X 35
35	P0457035	FLAT HD SCR M4-.7 X 6
36	P0457036	RACK
37	P0457037	HAND KNOB M10-1.5
38	P0457038	GUIDE POST
39	P0457039	CHANGE SHAFT
40	P0457040	PHLP HD SCR M6-1 X 12
41	P0457041	WASHER 6MM PLASTIC
42	P0457042	LOCK NUT M6-1
43	P0457043	UPPER BLADE GUIDE ASSEMBLY
44	P0457044	LOWER BLADE GUIDE ASSEMBLY
50	P0457050	SLIDING BLADE GUARD
51	P0457051	BLADE GUARD
52	P0457052	HEX BOLT M6-1 X 8
53	P0457053	FLAT WASHER 6MM
54	P0457054	FLANGE SCREW M6-1 X 8
55	P0457055	CAM
56	P0457056	LOCK COLLAR
57	P0457057	SET SCREW M5-.8 X 5
58	P0457058	TENSION ADJUSTMENT SCREW
59	P0457059	ADJUSTMENT SCREW BRACKET
60	P0457060	COMPRESSION SPRING
61	P0457061	TENSION INDICATOR
62	P0457062	THREADED PLATE
63	P0457063	LOCK KNOB M8-1.25 X 45
64	P0457064	KNOB M8-1.25
65	P0457065	FLAT WASHER 6MM
66	P0457066	PULL NUT M8-1.25
67	P0457067	BRACKET

REF	PART #	DESCRIPTION
68	P0457068	SQUARE SHAFT 12 X 12MM
69	P0457069	CAP SCREW M8-1.25 X 20
70	P0457070	LOCK WASHER 8MM
71	P0457071	FLAT WASHER 8MM
72	P0457072	SLEEVE
73	P0457073	UPPER WHEEL SHAFT BRACKET
74	P0457074	ROLL PIN 5 X 35
75	P0457075	UPPER WHEEL SHAFT
76	P0457076	WAVY WASHER 15 X 22MM
77	P0457077	UPPER WHEEL
78	P0457078	WHEEL TIRE
79	P0457079	HEX BOLT M8-1.25 X 16
80	P0457080	LOCK WASHER 8MM
81	P0457081	FLAT WASHER 8MM
82	P0457082	BALL BEARING 6202ZZ
83	P0457083	INT RETAINING RING 35MM
86	P0457086	HEX NUT M18-1.5
87	P0457087	LOCK WASHER 18MM
88	P0457088	LOWER WHEEL SHAFT
89	P0457089	LEFT BLADE COVER
90	P0457090	HEX NUT M8-1.25
91	P0457091	SET SCREW M8-1.25 X 20
92	P0457092	SHAFT END CAP
93	P0457093	FLANGE SCREW M5-.8 X 8
94	P0457094	DUST PORT
95	P0457095	FLANGE SCREW M6-1 X 10
96V2	P0457096V2	MOTOR 2HP 1PH 220/110V V2.05.11
96V2-1	P0457096V2-1	MOTOR FAN COVER
96V2-2	P0457096V2-2	MOTOR FAN
96V2-3	P0457096V2-3	S CAPACITOR COVER
96V2-4	P0457096V2-4	S CAPACITOR 300M 250V
96V2-5	P0457096V2-5	MOTOR JUNCTION BOX
96V2-6	P0457096V2-6	CENTRIFUGAL SWITCH
96V2-7	P0457096V2-7	CONTACT PLATE
96V2-8	P0457096V2-8	FRONT MOTOR BEARING
96V2-9	P0457096V2-9	REAR MOTOR BEARING
96V2-10	P0457096V2-10	R CAPACITOR COVER
96V2-11	P0457096V2-11	R CAPACITOR 40M 250V 1-3/8 X 2-3/8
97	P0457097	KEY 5 X 5 X 20
100	P0457100	CAP SCREW M6-1 X 20
101	P0457101	WHEEL COVER LATCH KNOB 6MM
102	P0457102	LOCK NUT M6-1
103	P0457103	ALIGNMENT PIN
104	P0457104	FLANGE SCREW M5-.8 X 6
105	P0457105	RIGHT BLADE COVER
111	P0457111	POINTER
112	P0457112	HEX BOLT M6-1 X 12
113	P0457113	FLAT WASHER 8MM
114	P0457114	LOCK WASHER 8MM
115	P0457115	CAP SCREW M8-1.25 X 20
116	P0457116	WHEEL BRUSH
117	P0457117	FLANGE SCREW M5-.8 X 8
118	P0457118	HEX BOLT M8-1.25 X 35



# Main Parts List (Continued)

REF	PART #	DESCRIPTION
119	P0457119	LOCK WASHER 8MM
120A	P0457120A	TRUNNION BRACKET CAST IRON
121	P0457121	HEX BOLT M8-1.25 X 80
122	P0457122	HEX NUT M8-1.25
123	P0457123	POINTER
124	P0457124	PHLP HD SCR M5-.8 X 6
125	P0457125	LOCK KNOB M10-1.5
126	P0457126	TABLE INSERT
127	P0457127	TABLE PIN
128	P0457128	TABLE
129	P0457129	HEX BOLT M10-1.5 X 50
130	P0457130	TRUNNION CLAMP SHOE 1PC
131A	P0457131A	TRUNNION CAST IRON
132	P0457132	SCALE
133	P0457133	FLANGE BOLT M6-1 X 12
134	P0457134	BLADE 106 X 3/8 X 0.35" 6TPI
135	P0457135	FLANGE SCREW M5-.8 X 8
136	P0457136	PHLP HD SCR M4-.7 X 10
137	P0457137	PHLP HD SCR M5-.8 X 12
138	P0457138	EXT TOOTH WASHER 5MM
139	P0457139	HEX NUT M5-.8

REF	PART #	DESCRIPTION
140V2	P0457140V2	POWER CORD 14G 3C 6-15 V2.05.11
141	P0457141	MOTOR CORD 14G 3C
142	P0457142	FLANGE SCREW M5-.8 X 8
143	P0457143	STRAIN RELIEF
144	P0457144	SWITCH BOX REAR PLATE
145	P0457145	SWITCH BOX FRONT PLATE
146V2	P0457146V2	ON/OFF SWITCH 110/220V V2.05.11
150	P0457150	POINTER BRACKET
151	P0457151	FLANGE SCREW M5-.8 X 12
157	P0457157	LEVER PLATE
158	P0457158	HEX BOLT M8-1.25 X 20
159	P0457159	LOCK WASHER 8MM
160	P0457160	FLAT WASHER 8MM
161	P0457161	SHIM PLASTIC
162	P0457162	SET SCREW M6-1 X 6
164	P0457164	SET SCREW M8-1.25 X 10
166	P0457166	HEX WRENCH 6MM
201	P0457201	WHEEL LOWER ASSEMBLY
202	P0457202	RIBBED BELT 200J5
203	P0457203	MOTOR PULLEY
204	P0457204	SET SCREW M6-1 X 10



# Components

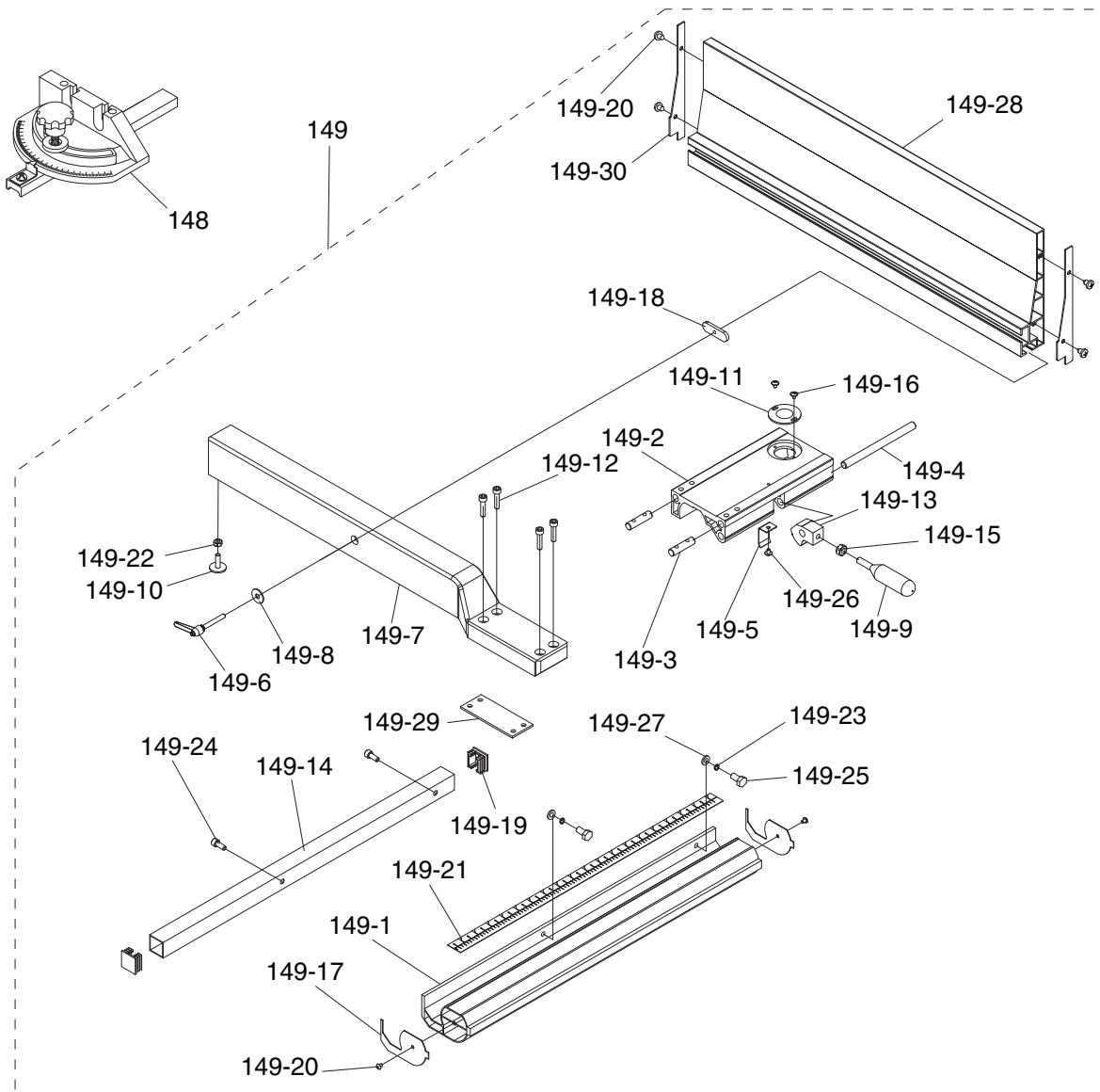

REF	PART #	DESCRIPTION
148	P0457148	MITER GAUGE ASSEMBLY
149	P0457149	RESAW FENCE ASSEMBLY
149-1	P0457149-1	FRONT FENCE RAIL 540MM
149-2	P0457149-2	FENCE BASE
149-3	P0457149-3	FENCE SUPPORT MOUNTING ROD
149-4	P0457149-4	LOCK ROD
149-5	P0457149-5	SPRING PIECE
149-6	P0457149-6	LOCK HANDLE ASSEMBLY M8-1.25 X 44
149-7	P0457149-7	FENCE SUPPORT 505MM
149-8	P0457149-8	FLAT WASHER 8MM
149-9	P0457149-9	LOCK HANDLE
149-10	P0457149-10	FENCE REAR STANDOFF
149-11	P0457149-11	SCALE WINDOW
149-12	P0457149-12	CAP SCREW M6-1 X 25
149-13	P0457149-13	LOCK CAM
149-14	P0457149-14	REAR FENCE RAIL

REF	PART #	DESCRIPTION
149-15	P0457149-15	HEX NUT M8-1.25
149-16	P0457149-16	FLANGE SCREW M4-.7 X 6
149-17	P0457149-17	FRONT RAIL END CAP
149-18	P0457149-18	FENCE MOVING PLATE
149-19	P0457149-19	REAR RAIL END CAP
149-20	P0457149-20	TAP SCREW M3.5 X 8
149-21	P0457149-21	SCALE
149-22	P0457149-22	HEX NUT M6-1
149-23	P0457149-23	LOCK WASHER 6MM
149-24	P0457149-24	CAP SCREW M6-1 X 16
149-25	P0457149-25	HEX BOLT M6-1 X 20
149-26	P0457149-26	FLANGE SCREW M4-.7 X 8
149-27	P0457149-27	FLAT WASHER 6MM
149-28	P0457149-28	FENCE 505MM ALUMINUM
149-29	P0457149-29	FENCE SUPPORT MOUNTING PLATE
149-30	P0457149-30	FENCE END CAP



# Stand

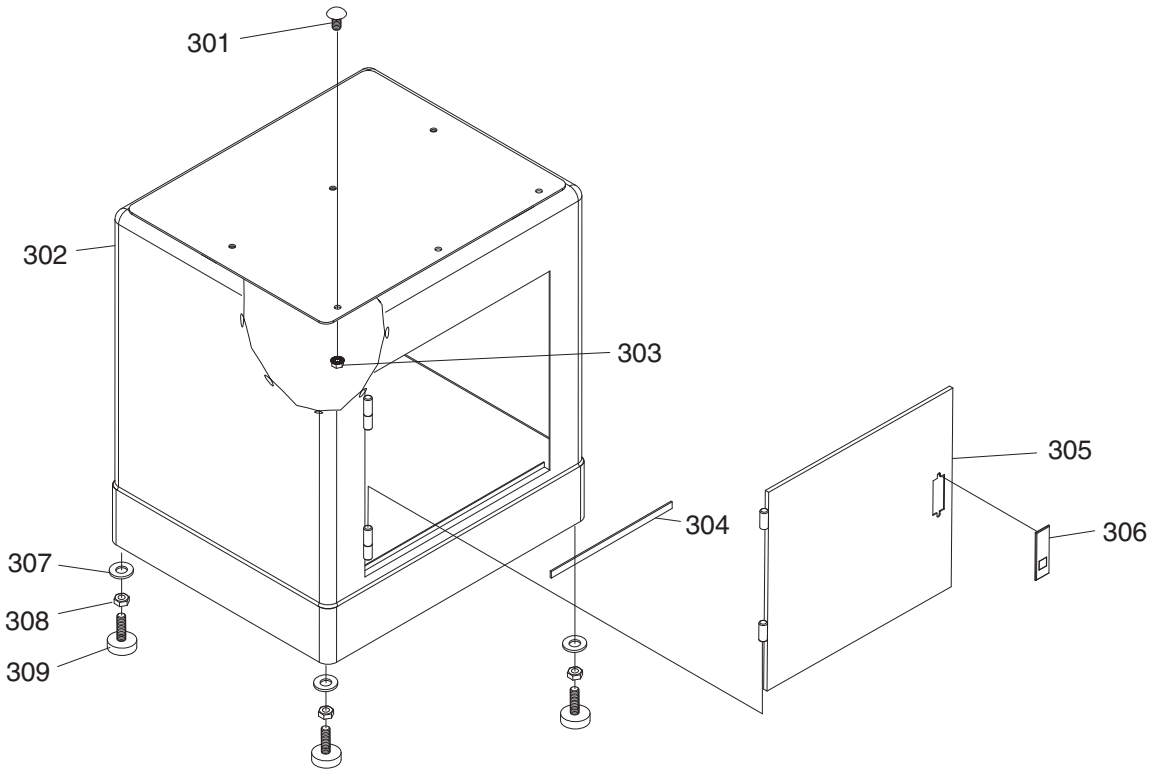

REF	PART #	DESCRIPTION
301	P0457301	CARRIAGE BOLT M8-1.25 X 20
302	P0457302	STAND
303	P0457303	FLANGE NUT M8-1.25
304	P0457304	FOAM TAPE
305	P0457305	DOOR

REF	PART #	DESCRIPTION
306	P0457306	LATCH ASSEMBLY
307	P0457307	FLAT WASHER 10MM
308	P0457308	HEX NUT 3/8-16
309	P0457309	FOOT 3/8-16 X 1-3/4



# Labels

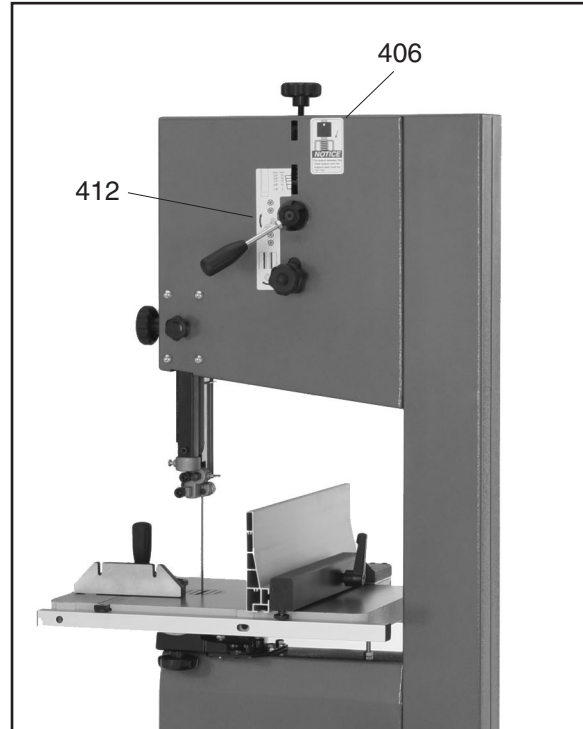
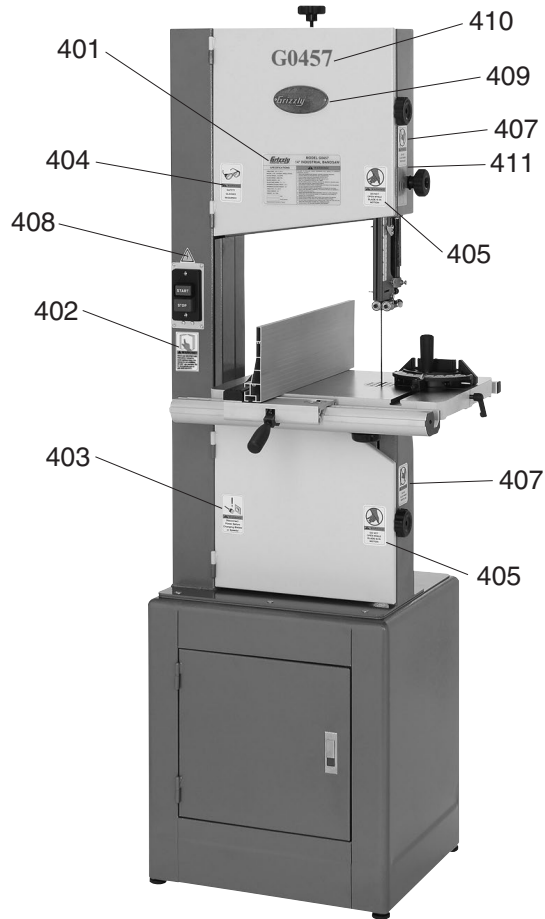

Rear of Machine

REF	PART #	DESCRIPTION
401	P0457401	MACHINE ID LABEL
402	P0457402	READ MANUAL LABEL
403	P0457403	UNPLUG BANDSAW LABEL
404	P0457404	SAFETY GLASSES LABEL
405	P0457405	DO NOT OPEN LABEL
406	P0457406	BLADE TENSION NOTICE LABEL

REF	PART #	DESCRIPTION
407	P0457407	HANDS NEAR BLADE LABEL
408	P0457408	ELECTRICITY LABEL
409	P0457409	GRIZZLY NAMEPLATE
410	P0457410	MODEL NUMBER LABEL
411	P0457411	BLADE GUARD ADJ LABEL
412	P0457412	BLADE TENSION SCALE/LABEL

## WARNING

Safety labels help reduce the risk of serious injury caused by machine hazards. If any label comes off or becomes unreadable, the owner of this machine **MUST** replace it in the original location before resuming operations. For replacements, contact (800) 523-4777 or [www.grizzly.com](http://www.grizzly.com).





# WARRANTY CARD

Name \_\_\_\_\_  
 Street \_\_\_\_\_  
 City \_\_\_\_\_ State \_\_\_\_\_ Zip \_\_\_\_\_  
 Phone # \_\_\_\_\_ Email \_\_\_\_\_  
 Model # \_\_\_\_\_ Order # \_\_\_\_\_ Serial # \_\_\_\_\_

The following information is given on a voluntary basis. It will be used for marketing purposes to help us develop better products and services. **Of course, all information is strictly confidential.**

1. How did you learn about us?

Advertisement                       Friend                       Catalog  
 Card Deck                                 Website                       Other:

2. Which of the following magazines do you subscribe to?

<input type="checkbox"/> Cabinetmaker & FDM	<input type="checkbox"/> Popular Science	<input type="checkbox"/> Wooden Boat
<input type="checkbox"/> Family Handyman	<input type="checkbox"/> Popular Woodworking	<input type="checkbox"/> Woodshop News
<input type="checkbox"/> Hand Loader	<input type="checkbox"/> Precision Shooter	<input type="checkbox"/> Woodsmith
<input type="checkbox"/> Handy	<input type="checkbox"/> Projects in Metal	<input type="checkbox"/> Woodwork
<input type="checkbox"/> Home Shop Machinist	<input type="checkbox"/> RC Modeler	<input type="checkbox"/> Woodworker West
<input type="checkbox"/> Journal of Light Cont.	<input type="checkbox"/> Rifle	<input type="checkbox"/> Woodworker's Journal
<input type="checkbox"/> Live Steam	<input type="checkbox"/> Shop Notes	<input type="checkbox"/> Other:
<input type="checkbox"/> Model Airplane News	<input type="checkbox"/> Shotgun News	
<input type="checkbox"/> Old House Journal	<input type="checkbox"/> Today's Homeowner	
<input type="checkbox"/> Popular Mechanics	<input type="checkbox"/> Wood	

3. What is your annual household income?

\$20,000-\$29,000                       \$30,000-\$39,000                       \$40,000-\$49,000  
 \$50,000-\$59,000                       \$60,000-\$69,000                       \$70,000+

4. What is your age group?

20-29     30-39     40-49  
 50-59     60-69     70+

5. How long have you been a woodworker/metalworker?

0-2 Years                       2-8 Years                       8-20 Years                       20+ Years

6. How many of your machines or tools are Grizzly?

0-2                       3-5                       6-9                       10+

7. Do you think your machine represents a good value?     Yes                       No

8. Would you recommend Grizzly Industrial to a friend?     Yes                       No

9. Would you allow us to use your name as a reference for Grizzly customers in your area?  
**Note: We never use names more than 3 times.**                       Yes                       No

10. Comments: \_\_\_\_\_  
 \_\_\_\_\_  
 \_\_\_\_\_  
 \_\_\_\_\_

CUT ALONG DOTTED LINE

FOLD ALONG DOTTED LINE

\_\_\_\_\_
\_\_\_\_\_
\_\_\_\_\_



Place Stamp Here



GRIZZLY INDUSTRIAL, INC.
P.O. BOX 2069
BELLINGHAM, WA 98227-2069



FOLD ALONG DOTTED LINE

Send a Grizzly Catalog to a friend:

Name \_\_\_\_\_
Street \_\_\_\_\_
City \_\_\_\_\_ State \_\_\_\_\_ Zip \_\_\_\_\_

TAPE ALONG EDGES--PLEASE DO NOT STAPLE

# WARRANTY & RETURNS

---

---

Grizzly Industrial, Inc. warrants every product it sells for a period of **1 year** to the original purchaser from the date of purchase. This warranty does not apply to defects due directly or indirectly to misuse, abuse, negligence, accidents, repairs or alterations or lack of maintenance. This is Grizzly's sole written warranty and any and all warranties that may be implied by law, including any merchantability or fitness, for any particular purpose, are hereby limited to the duration of this written warranty. We do not warrant or represent that the merchandise complies with the provisions of any law or acts unless the manufacturer so warrants. In no event shall Grizzly's liability under this warranty exceed the purchase price paid for the product and any legal actions brought against Grizzly shall be tried in the State of Washington, County of Whatcom.

We shall in no event be liable for death, injuries to persons or property or for incidental, contingent, special, or consequential damages arising from the use of our products.

To take advantage of this warranty, contact us by mail or phone and give us all the details. We will then issue you a "Return Number," which must be clearly posted on the outside as well as the inside of the carton. We will not accept any item back without this number. Proof of purchase must accompany the merchandise.

The manufacturers reserve the right to change specifications at any time because they constantly strive to achieve better quality equipment. We make every effort to ensure that our products meet high quality and durability standards and we hope you never need to use this warranty.

Please feel free to write or call us if you have any questions about the machine or the manual.

Thank you again for your business and continued support. We hope to serve you again soon.

**grizzly.com**<sup>®</sup>  
**TOOL WEBSITE**

Buy Direct and Save with Grizzly<sup>®</sup> – Trusted, Proven and a Great Value!  
~Since 1983~

*Visit Our Website Today For  
Current Specials!*

**ORDER  
24 HOURS A DAY!  
1-800-523-4777**

